

RETAINING WALL #41:

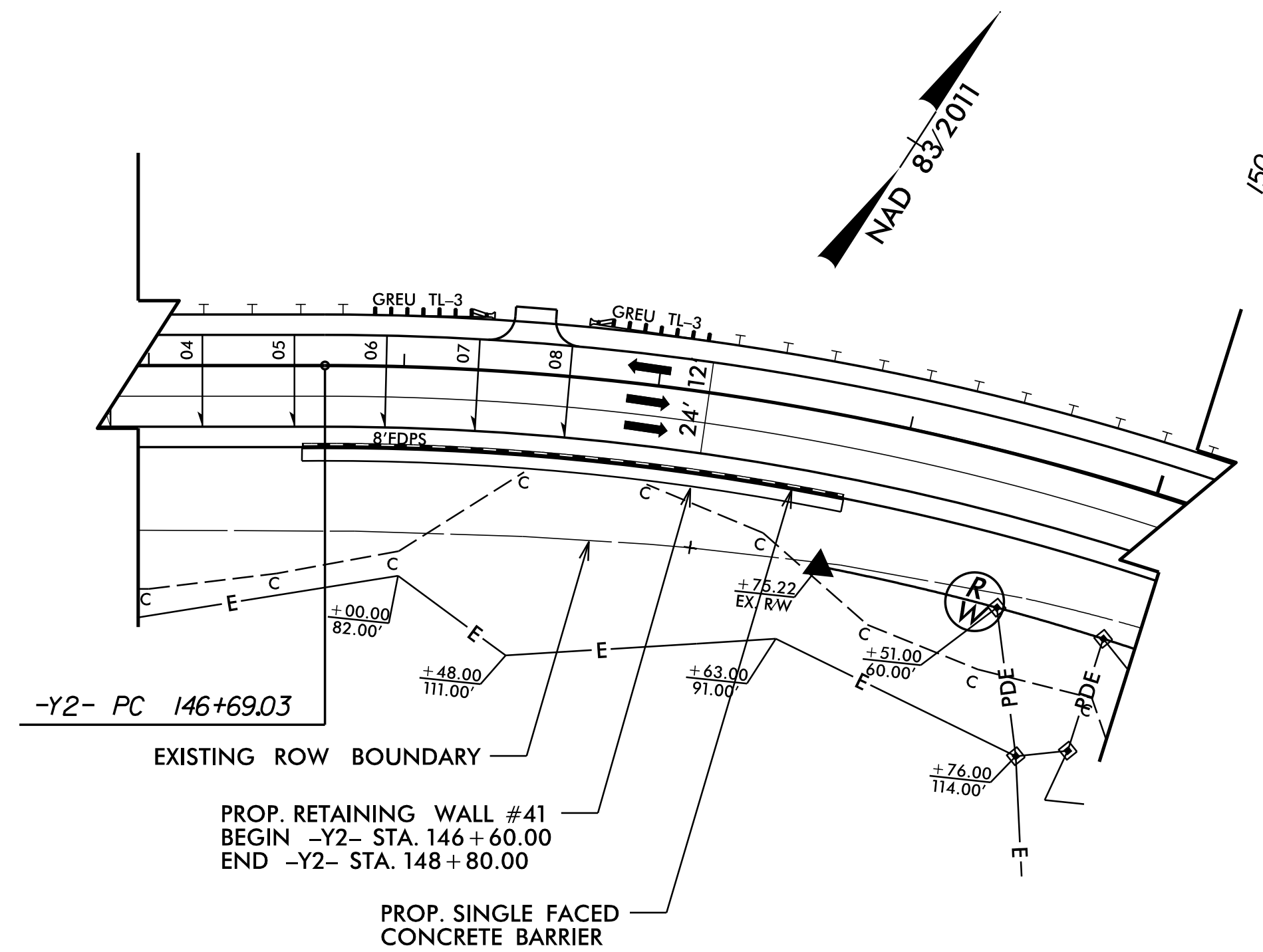

RETAINING WALL #41 – PLAN
NOT TO SCALE

GEOTECHNICAL ENGINEER

ENGINEER

PROFESSIONAL SEAL 042642

ROBERT E. KRAL

DocuSigned by: [Signature] DATE: 1/15/2023

DOCUMENT NOT CONSIDERED FINAL UNLESS ALL SIGNATURES COMPLETED

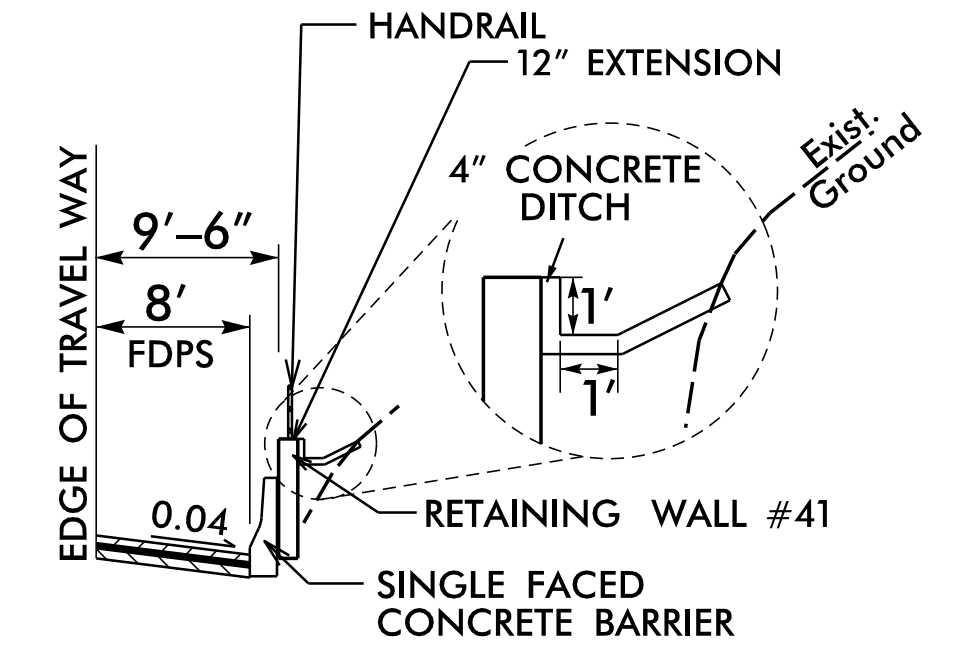

DETAIL FOR WALL #41
NOT TO SCALE
-Y2- STA. 146+60.00 TO -Y2- STA. 148+80.00, RT

ESTIMATED SOIL NAIL WALL QUANTITIES			
RETAINING WALL NO.	SOIL NAIL RETAINING WALLS (SQUARE FEET)	SOIL NAIL VERIFICATION TESTS	SOIL NAIL PROOF TESTS
41	1,440 *	1	5
HORIZONTAL DRAINS (CONTINGENCY)			110 LF

*INCLUDES RETAINING WALL EMBEDMENT

THE WALL ENVELOPE DOES NOT ACCURATELY DEPICT THE ACTUAL WALL FACE OF WALL #41 AT THE FOLLOWING LOCATION:
-Y2- STA. 146+69.03 TO 148+80.00, RT

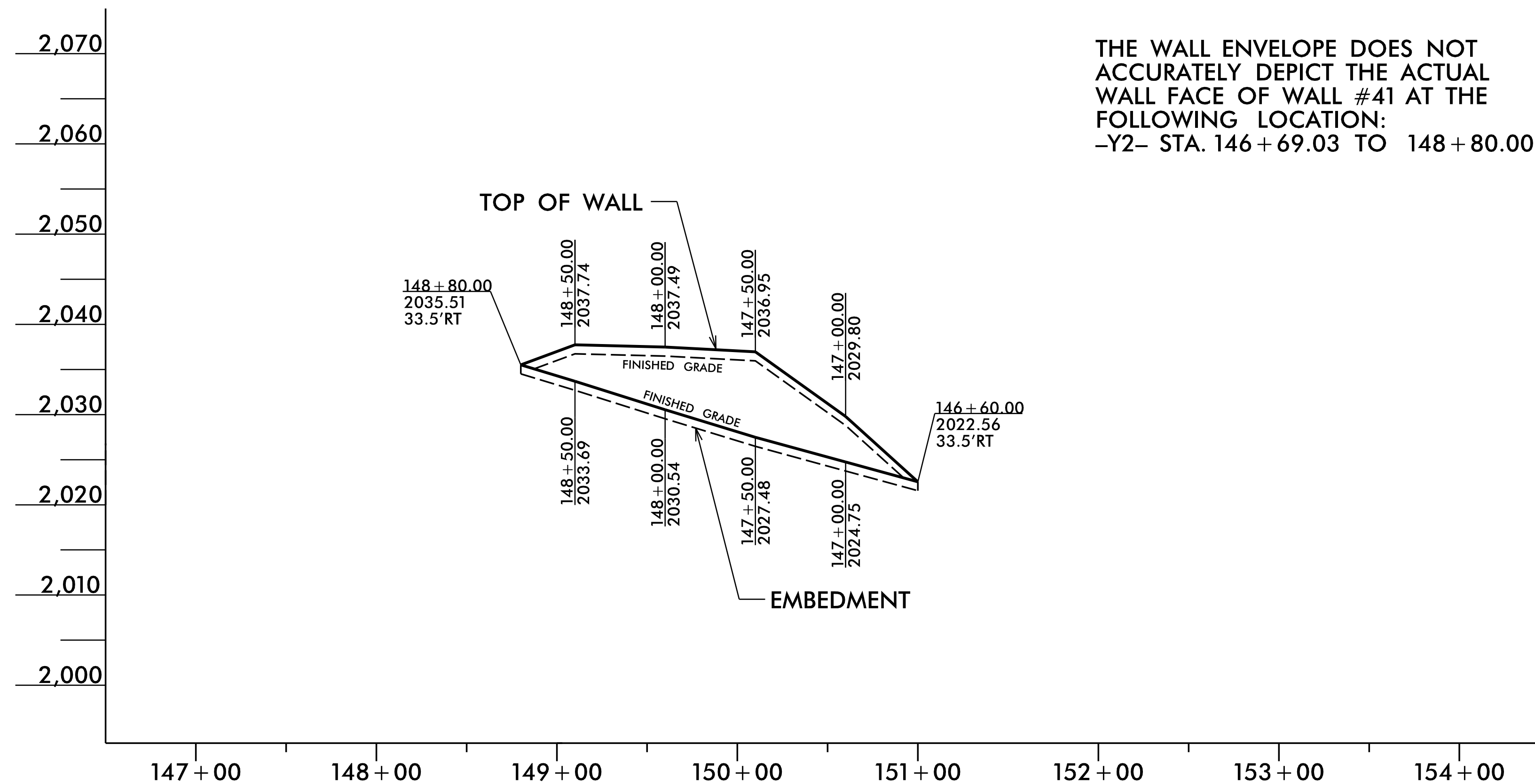

RETAINING WALL #41 – ENVELOPE
NOT TO SCALE
(LOOKING AT FACE OF WALL)

SOIL NAIL RETAINING WALL #41						
STA. -Y2-	OFFSET FROM -Y2 (RT) FT.	ELEV. @ TOP OF WALL	BOW FINISHED GRADE	TOP OF LEVELING PAD	ESTIMATED WALL EMBEDMENT FT.	WALL DESIGN HEIGHT "H"
146+60.00	33.50	2022.56	2022.56	2021.56	1.00	1.00
147+00.00	33.50	2029.80	2024.75	2023.75	1.00	5.05
147+50.00	33.50	2036.95	2027.48	2026.48	1.00	9.47
148+00.00	33.50	2037.49	2030.54	2029.54	1.00	6.95
148+50.00	33.50	2037.74	2033.69	2032.69	1.00	4.05
148+80.00	33.50	2035.51	2035.51	2034.51	1.00	1.00

BOW = BOTTOM OF WALL
ALL MEASUREMENTS ARE IN FEET

PROJECT NO.: A-0009CD
GRAHAM COUNTY
RETAINING WALL #41: -Y2- 146+60, 34' RT TO 148+80, 34' RT
SHEET 1 OF 3

PREPARED BY: R. KRAL
REVIEWED BY: M. BREWER

DATE: 1/15/2023
DATE: 1/15/2023

RETAINING WALL #41 ENVELOPE AND WALL LAYOUT PROVIDED BY TGS ENGINEERS, INC.

Prepared in the Office of:

CGE CAROLINAS GEOTECHNICAL GROUP
2400 CROWPOINT EXECUTIVE DRIVE
SUITE 800
CHARLOTTE, NC 28227
(980) 339-8684

NORTH CAROLINA DEPARTMENT OF TRANSPORTATION DIVISION OF HIGHWAYS

GEOTECHNICAL ENGINEERING UNIT

REVISIONS						SHEET NO.
NO.	BY	DATE	NO.	BY	DATE	
1			3			W41-1
2			4			

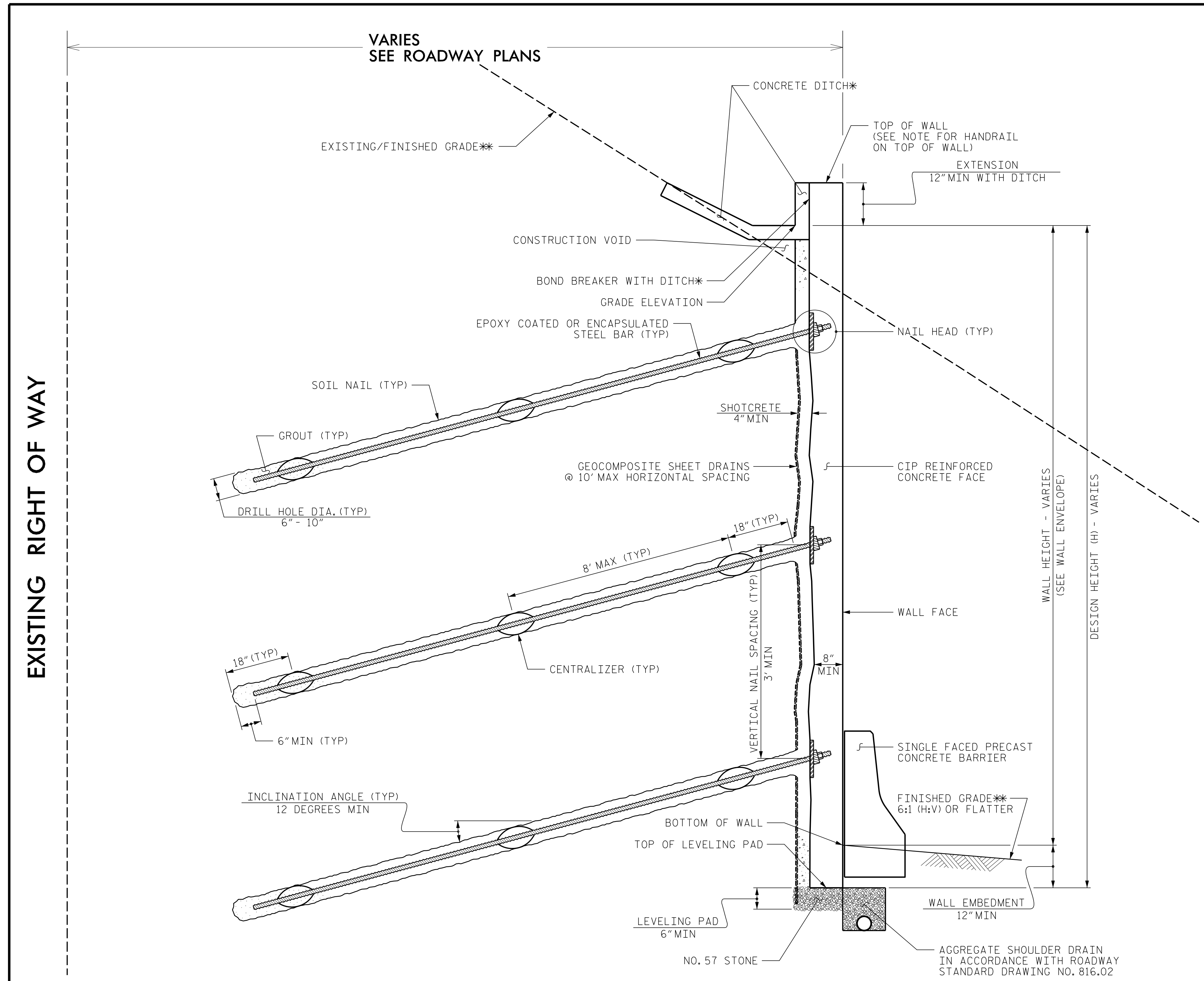

VARIES
SEE ROADWAY PLANS

EXISTING RIGHT OF WAY

SOIL NAIL WALL - TYPICAL SECTION

*SEE CONCRETE DITCH BEHIND WALL DETAILS.
**SEE PLANS FOR FINISHED GRADE.

GEOTECHNICAL ENGINEER  SEAL 042642 ROBERT E. KRAL	ENGINEER _____ SIGNATURE
Date Signed by: _____ DATE: 1/15/2023	DATE: _____ SIGNATURE: _____ DATE: _____
DOCUMENT NOT CONSIDERED FINAL UNLESS ALL SIGNATURES COMPLETED	

NOTES:

- FOR SOIL NAIL RETAINING WALLS, SEE SOIL NAIL RETAINING WALLS PROVISION.
- FOR SINGLE FACED PRECAST CONCRETE BARRIER, SEE ROADWAY PLANS AND SECTION 857 OF THE STANDARD SPECIFICATIONS.
- A HANDRAIL IS REQUIRED ON TOP OF RETAINING WALL #41. SEE ROADWAY PLANS FOR FENCE ATTACHMENT DETAILS.
- BEFORE BEGINNING SOIL NAIL WALL DESIGN FOR RETAINING WALL #41, SURVEY WALL LOCATION AND SUBMIT A REVISED WALL PROFILE VIEW (WALL ENVELOPE) FOR REVIEW. DO NOT START WALL DESIGN OR CONSTRUCTION UNTIL THE REVISED WALL ENVELOPE IS ACCEPTED.
- DESIGN RETAINING WALL #41 FOR THE FOLLOWING:
 - 1) DESIGN HEIGHT (H) = WALL HEIGHT + WALL EMBEDMENT
 - 2) DESIGN LIFE = 75 YEARS
 - 3) MINIMUM WALL EMBEDMENT ELEVATION = VARIES (MIN. 1 FT BELOW PROPOSED FINISHED GRADE ELEVATION)
 - 4) IN-SITU ASSUMED MEDIUM DENSE TO VERY DENSE RESIDUAL SOIL PARAMETERS:
 - UNIT WEIGHT, $\gamma = 125$ PCF
 - FRICTION ANGLE, $\phi = 36$ DEGREES
 - COHESION, $c = 0$ PSF
 - 5) IN-SITU ASSUMED MEDIUM STIFF TO VERY STIFF RESIDUAL SOIL PARAMETERS:
 - UNIT WEIGHT, $\gamma = 125$ PCF
 - FRICTION ANGLE, $\phi = 34$ DEGREES
 - COHESION, $c = 0$ PSF
 - 6) IN-SITU ASSUMED WEATHERED ROCK PARAMETERS:
 - UNIT WEIGHT, $\gamma = 135$ PCF
 - FRICTION ANGLE, $\phi = 32$ DEGREES
 - COHESION, $c = 500$ PSF
 - 7) IN-SITU ASSUMED CRYSTALLINE ROCK PARAMETERS:
 - UNIT WEIGHT, $\gamma = 170$ PCF
 - FRICTION ANGLE, $\phi = 34$ DEGREES
 - COHESION, $c = 1,000$ PSF
 - 8) WHERE ROCK IS ENCOUNTERED IN THE WALL ENVELOPE, DESIGNERS SHOULD REFER TO THE FHWA PRESUMPTIVE STRENGTH PARAMETERS OR OTHER REPRESENTATIVE AND REPEATABLE VALUES AND PROVIDE SOURCE REFERENCES IN THEIR DESIGN SUBMITTAL.
- WHEN ANALYZING FOR INFINITE SLOPE CONDITIONS, DESIGNERS SHOULD ANALYZE UP TO TWO (2) TIMES THE WALL HEIGHT BEHIND THE WALL FACE FOR FAILURE PLANE SEARCHES. THIS INFORMATION SHOULD BE INCLUDED WITH THE DESIGN SUBMITTAL.
- EXISTING OR FUTURE OBSTRUCTIONS SUCH AS FOUNDATIONS, GUARDRAIL, FENCE OR HANDRAIL POSTS, PAVEMENTS, PIPES, INLETS OR UTILITIES MAY INTERFERE WITH SOIL NAILS FOR RETAINING WALL #41.
- THE EXISTING RIGHT OF WAY (ROW) BOUNDARY VARIES FROM THE FACE OF RETAINING WALL #41. SEE THE ROADWAY PLANS FOR OFFSET DISTANCES FROM THE FACE OF RETAINING WALL #41. SOIL NAILS MAY NOT BE INSTALLED BEYOND THE EXISTING ROW BOUNDARY. SEE "SOIL NAIL WALL - TYPICAL SECTION" DETAIL.
- IF GROUNDWATER IS ENCOUNTERED BEHIND THE FACE OF RETAINING WALL #41, HORIZONTAL DRAINS MAY BE REQUIRED AS DIRECTED BY THE ENGINEER. FOR HORIZONTAL DRAINS, SEE THE RETAINING WALL HORIZONTAL DRAIN DETAIL.
- WHERE ROCK IS PRESENT IN THE WALL ENVELOPE, CONTROLLED BLASTING IS RECOMMENDED, BUT NOT REQUIRED, TO MAINTAIN THE NEAT EXCAVATION LINE. VOIDS, RESULTING FROM BLASTING OR EXCAVATING, THAT EXTEND BEYOND THE NEAT LINES ARE TO BE FILLED WITH A COMBINATION OF SHORT SOIL NAILS, WELDED WIRE, AND SHOTCRETE, AT THE DISCRETION OF THE ENGINEER. THE COSTS ASSOCIATED WITH THIS WORK WILL BE CONSIDERED INCIDENTAL TO WALL CONSTRUCTION AND NO ADDITIONAL COMPENSATION WILL BE MADE. FOR BLASTING, SEE THE BLASTING PROVISION.
- WHERE CONSTRUCTION VOIDS EXIST ALONG THE TOP OF RETAINING WALL #41, THE CONTRACTOR SHOULD BE PREPARED TO FORM THE CANTILEVERED SECTION OF THE CIP REINFORCED CONCRETE FACE TO THE TOP OF WALL ELEVATION. THE CONSTRUCTION VOID SHOULD BE FILLED WITH CONCRETE OR SHOTCRETE PRIOR TO CONSTRUCTION OF THE CONCRETE DITCH. ADDITIONAL WALL FACE REINFORCEMENT OR SOIL NAILS MAY BE REQUIRED FOR TALLER THAN TYPICAL CANTILEVER FACE HEIGHTS.

PROJECT NO.: A-0009CD
 GRAHAM COUNTY
 RETAINING WALL #41: -Y2- 146+60, 34' RT TO 148+80, 34' RT
 SHEET 2 OF 3

PREPARED BY: R. KRAL	DATE: 1/15/2023
REVIEWED BY: M. BREWER	DATE: 1/15/2023

Prepared in the Office of:



**CAROLINAS
GEOTECHNICAL
GROUP**
 2400 CROWNPOINT EXECUTIVE DRIVE
 SUITE 800
 CHARLOTTE, NC 28227
 (980) 339-8684

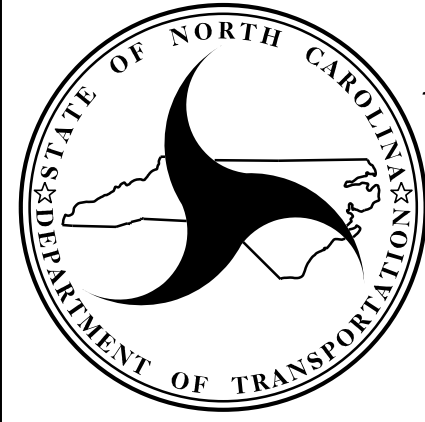

**NORTH CAROLINA
DEPARTMENT OF TRANSPORTATION
DIVISION OF HIGHWAYS**

**GEOTECHNICAL
ENGINEERING UNIT**

REVISIONS						SHEET NO.
NO.	BY	DATE	NO.	BY	DATE	
1			3			W41-2
2			4			

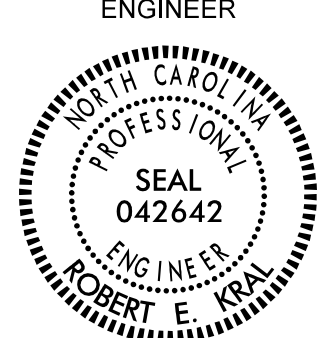
GEOTECHNICAL ENGINEER  SEAL 042642 ROBERT E. KRAL	ENGINEER DATE: 1/15/2023 SIGNATURE: _____ DATE: _____
DOCUMENT NOT CONSIDERED FINAL UNLESS ALL SIGNATURES COMPLETED	

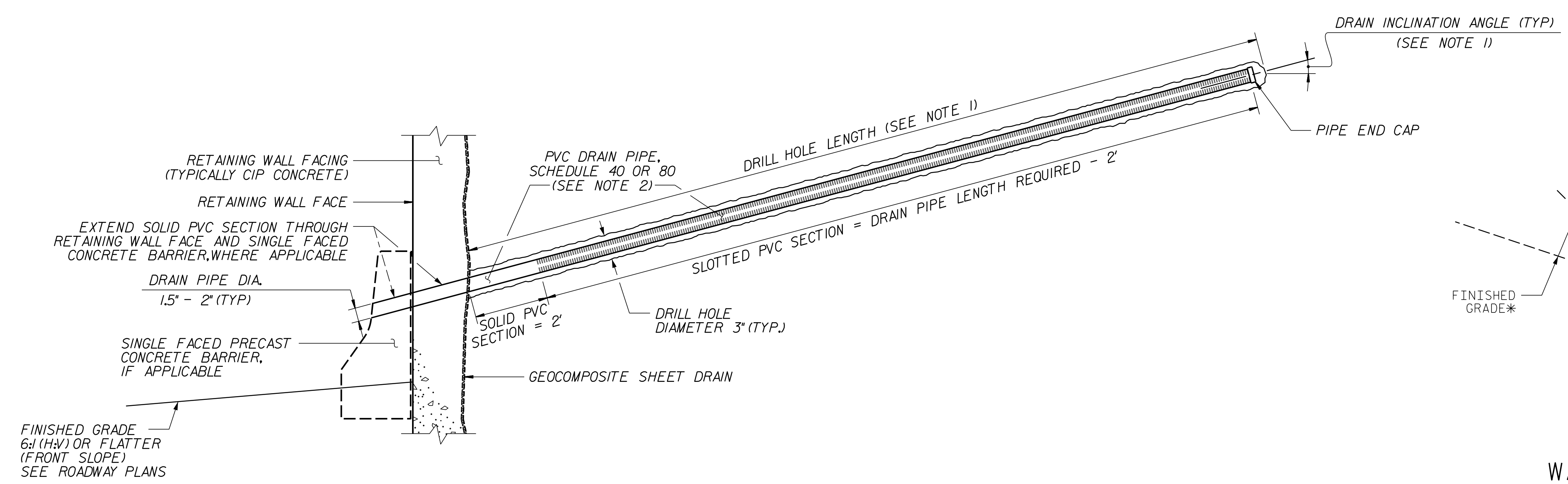

RETAINING WALL HORIZONTAL DRAIN

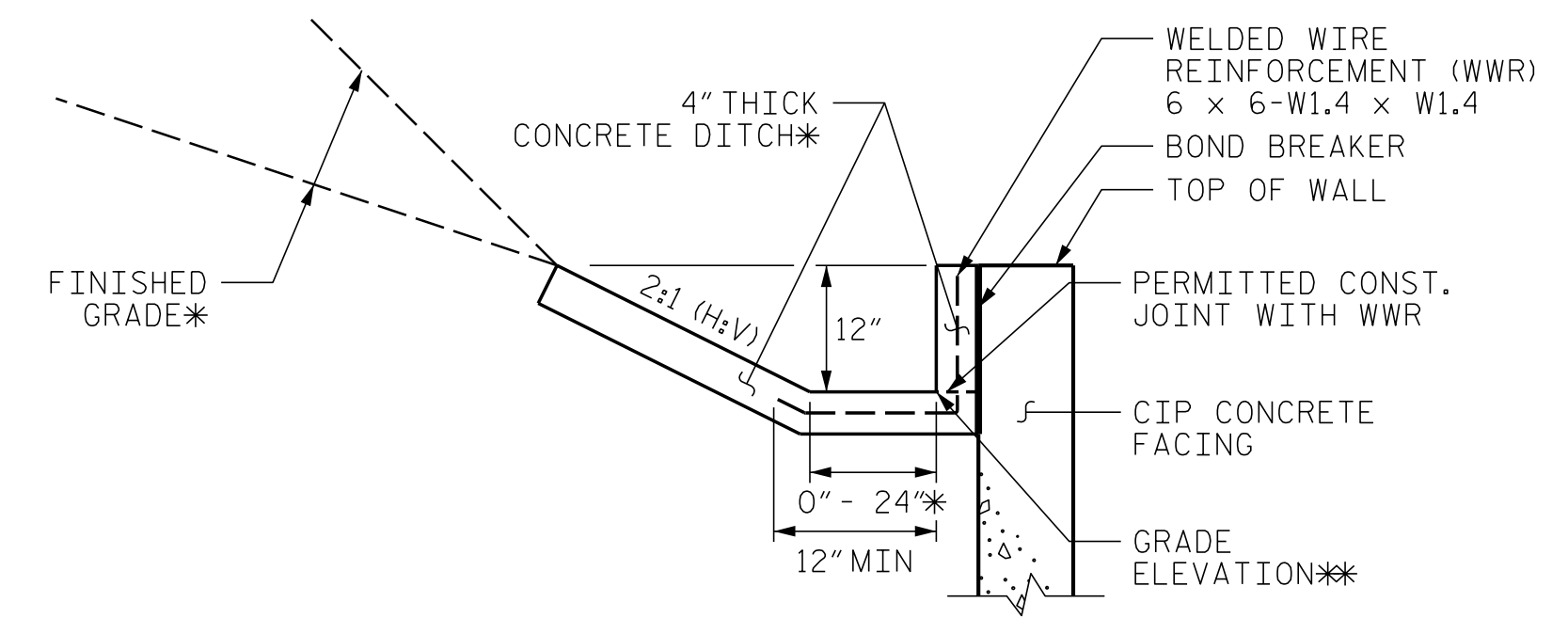

CONCRETE DITCH BEHIND WALL WITH CONCRETE FACING

*SEE ROADWAY PLANS FOR CONCRETE DITCH AND FINISHED GRADE DETAILS.
**SEE WALL ENVELOPE FOR GRADE ELEVATIONS.

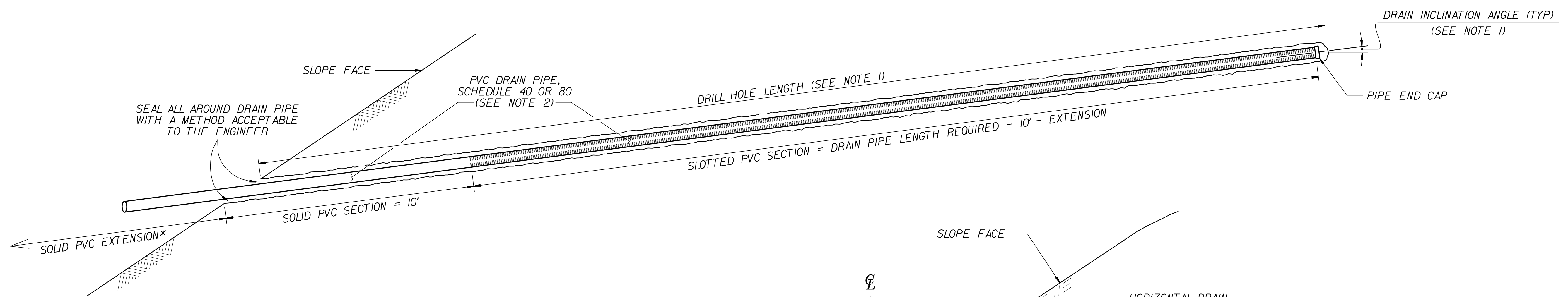

SLOPE HORIZONTAL DRAIN

*EXTEND SOLID PVC SECTION TO CONNECT PIPE TO A DRAINAGE SYSTEM OR DISCHARGE WATER AS DIRECTED

EXAMPLE CROSS-SECTION WITH SLOPE HORIZONTAL DRAIN

*SEE NOTE 1 FOR DRAIN ELEVATIONS ABOVE (OR BELOW) GRADE

NOTES:

1. SEE ROADWAY SUMMARY SHEETS FOR APPROXIMATE KNOWN HORIZONTAL DRAIN LOCATIONS, ELEVATIONS, INCLINATION AND LENGTHS. ADDITIONAL DRAINS MAY BE REQUIRED AS DETERMINED BY THE ENGINEER.
2. DRAIN PIPES MAY BE OMITTED FOR SOME HORIZONTAL DRAINS. SEE ROADWAY SUMMARY SHEETS FOR DRAIN PIPE REQUIREMENTS INCLUDING THOSE DRAINS WITHOUT PIPES.
3. FOR HORIZONTAL DRAINS, SEE HORIZONTAL DRAINS SPECIAL PROVISION (GT-6).

PROJECT NO.: A-0009CD
 GRAHAM COUNTY
 RETAINING WALL #41: -Y2- 146+60, 34' RT TO 148+80, 34' RT
 SHEET 3 OF 3

PREPARED BY: R. KRAL	DATE: 1/15/2023
REVIEWED BY: M. BREWER	DATE: 1/15/2023

Prepared in the Office of:



CARLINAS GEOTECHNICAL GROUP
 2400 CROWNPOINT EXECUTIVE DRIVE
 SUITE 800
 CHARLOTTE, NC 28227
 (980) 339-8684

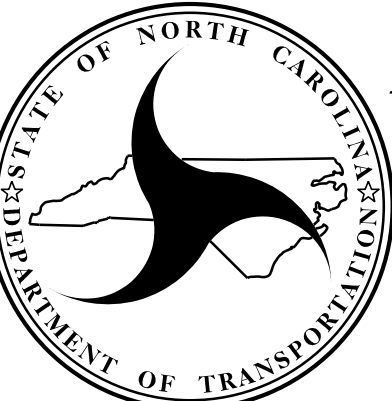

NORTH CAROLINA DEPARTMENT OF TRANSPORTATION DIVISION OF HIGHWAYS

GEOTECHNICAL ENGINEERING UNIT

REVISIONS						SHEET NO.
NO.	BY	DATE	NO.	BY	DATE	
1			3			W41-3
2			4			