

T.I.P.: A-0009CD

STATE OF NORTH CAROLINA DEPARTMENT OF TRANSPORTATION

PAVEMENT MARKING PLAN GRAHAM COUNTY

LOCATION: NC 28 FROM 0.2 MI WEST OF SR 1228 (STECOAH RD) TO 0.3 MI EAST OF SR 1235 (GUNTER CAP RD)

TIP NO. SHEET NO. A-0009CD PMP-1 APPROVED: Jimmy Terry DATE: 2/27/2026 SEAL DOCUMENT NOT CONSIDERED FINAL UNLESS ALL SIGNATURES COMPLETED

INDEX

Table with 2 columns: SHEET NO., DESCRIPTION. Rows include PMP-1, PMP-1A, PMP-1B, and PMP-2 THRU PMP-4.

GENERAL NOTES

THE FOLLOWING GENERAL NOTES APPLY AT ALL TIMES FOR THE DURATION OF THE CONSTRUCTION PROJECT... A) INSTALL PAVEMENT MARKINGS AND PAVEMENT MARKERS ON THE FINAL SURFACE AS FOLLOWS: ROAD NAME MARKING MARKER... B) TIE PROPOSED PAVEMENT MARKING LINES TO EXISTING PAVEMENT MARKING LINES.

FINAL PAVEMENT MARKING SCHEDULE

Table with 2 columns: SYMBOL, DESCRIPTION. Lists various pavement markings like T1, T2, T3, T4, T5, T10, T13, T52, T61, T70, T79.

ROADWAY STANDARD DRAWING

THE FOLLOWING ROADWAY STANDARDS AS APPEAR IN "ROADWAY STANDARD DRAWINGS" - PROJECT SERVICES UNIT - N.C. DEPARTMENT OF TRANSPORTATION - RALEIGH, N.C., DATED JANUARY 2024 ARE APPLICABLE TO THIS PROJECT AND BY REFERENCE HEREBY ARE CONSIDERED A PART OF THESE PLANS:

Table with 2 columns: STD. NO., TITLE. Lists standards like 1205.01 PAVEMENT MARKINGS - LINE TYPES AND OFFSETS, 1205.02 PAVEMENT MARKINGS - TWO-LANE AND MULTILANE ROADWAYS, etc.

PLAN SUBMITTED TO: NCDOT DIVISION 14 JEANETTE WHITE, PE NCDOT DIVISION 14

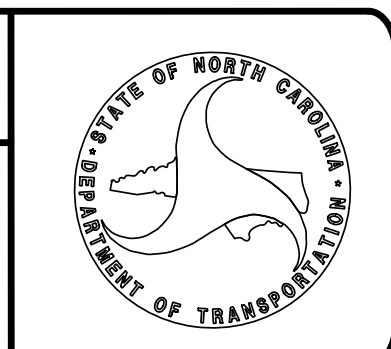

PLAN PREPARED BY: TGS ENGINEERS JIMMY TERRY, PE PROJECT ENGINEER SANDRA MELVIN DESIGN TECHNICIAN

TGS ENGINEERS logo and contact information: 201 W. MARION ST SHELBY, NC 28150 PH (704) 476-0003 CORP. LICENSE NO.: C-0275

12/31/2025 X:\NCDOT\A-0009\Traffic\Pavement\_Markings\A-0009CD\A-0009CD\_Sgn\_PMP\_01.dgn User:srmelvin

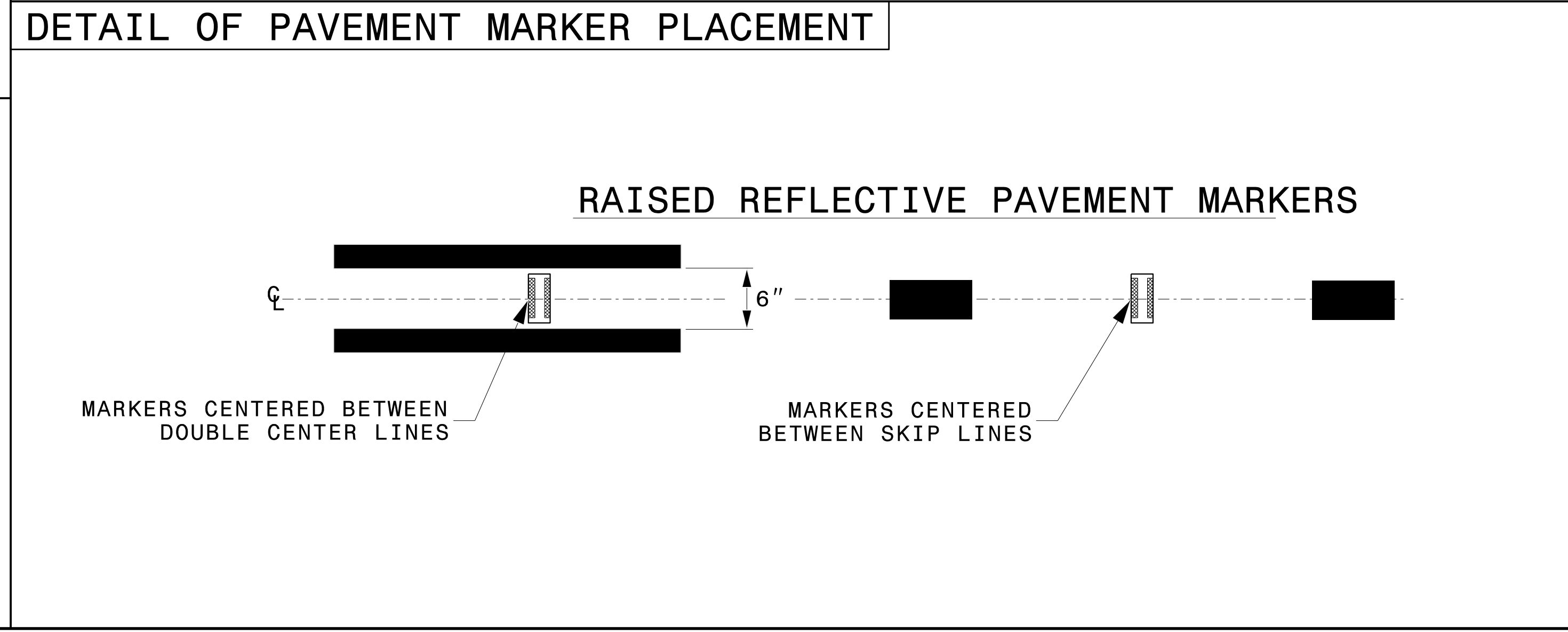
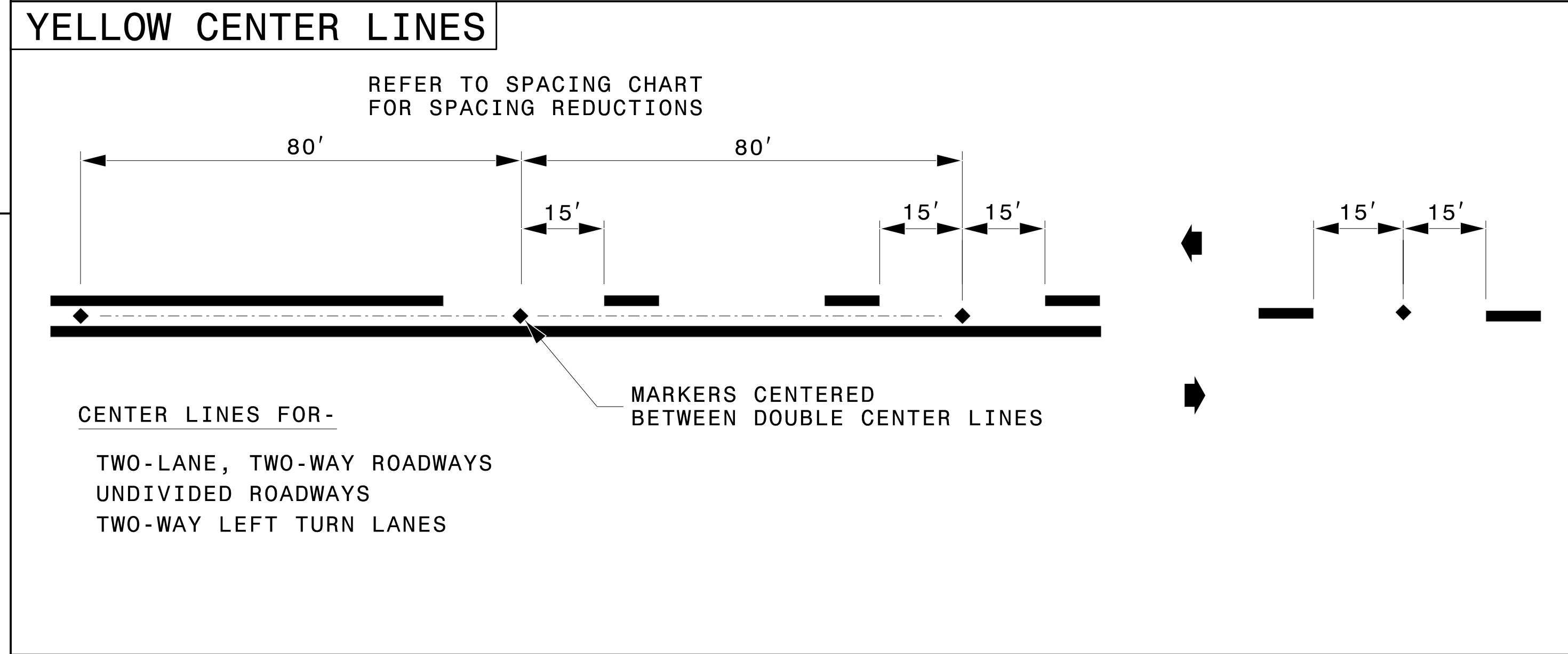
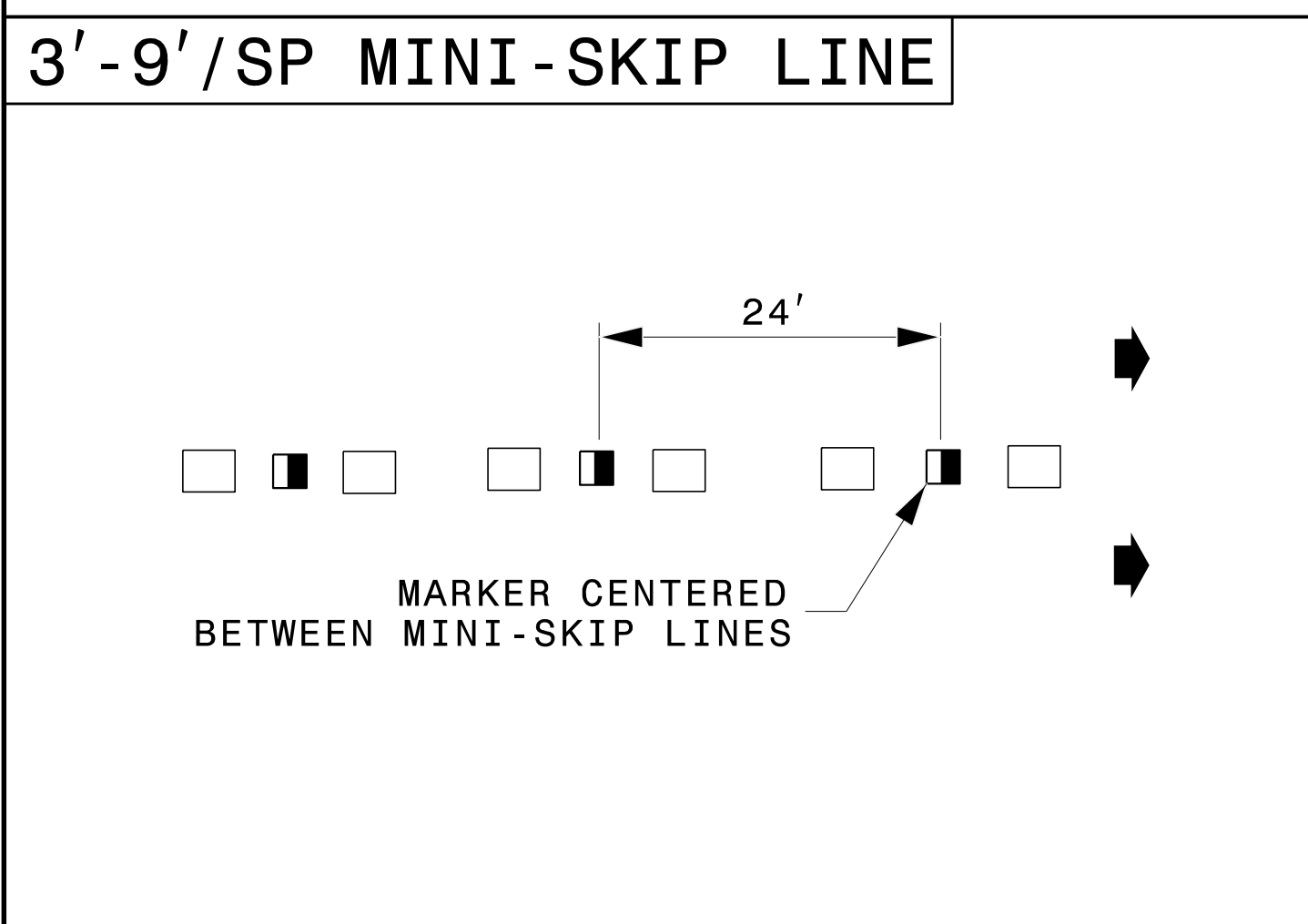
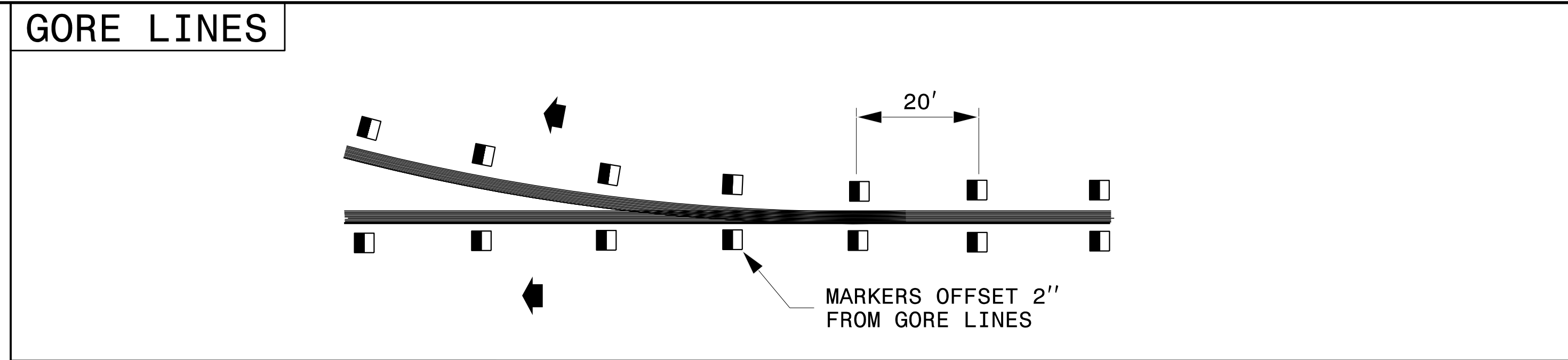
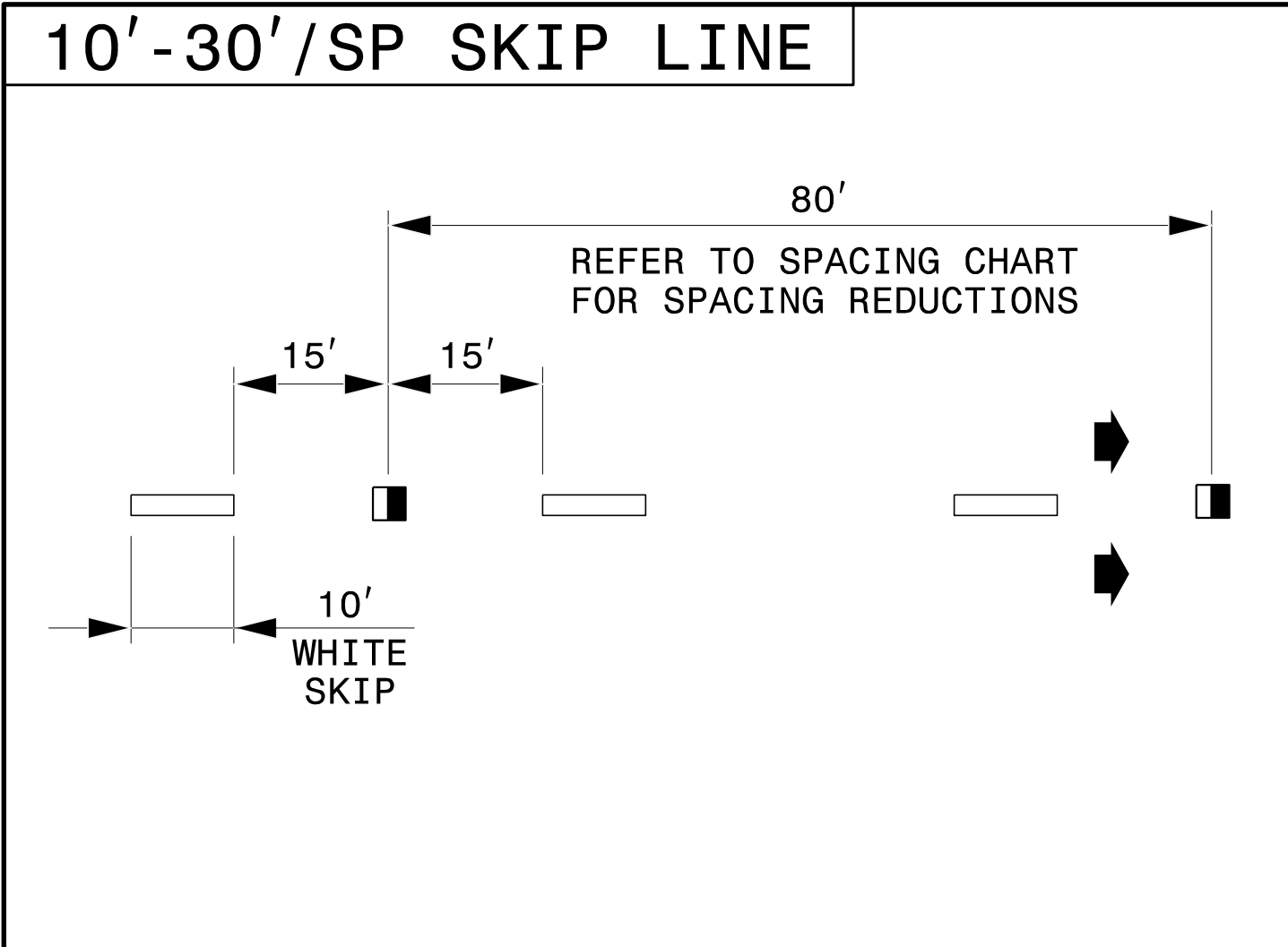

**LEGEND**

	CRYSTAL/RED PAVEMENT MARKER
	YELLOW/YELLOW PAVEMENT MARKER
	DIRECTION OF TRAFFIC FLOW

STATE OF NORTH CAROLINA  
DEPT. OF TRANSPORTATION  
DIVISION OF HIGHWAYS  
RALEIGH, N.C.

ROADWAY DETAIL DRAWING FOR  
**RAISED PAVEMENT MARKERS**  
INSTALLATION SPACING

SHEET 2 OF 3  
**1250D01**

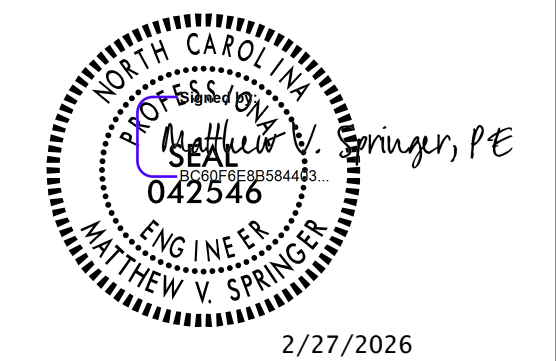

**CONTRACTS STANDARDS AND DEVELOPMENT UNIT**  
Office 919-707-8950 FAX 919-250-4119

**SEE TITLE BLOCK**

ORIGINAL BY: M.V. SPRINGER DATE: 2-15-24  
 MODIFIED BY: DATE: \_\_\_\_\_  
 CHECKED BY: DATE: \_\_\_\_\_  
 FILE SPEC.: \_\_\_\_\_

**CONTINUOUS LINES**

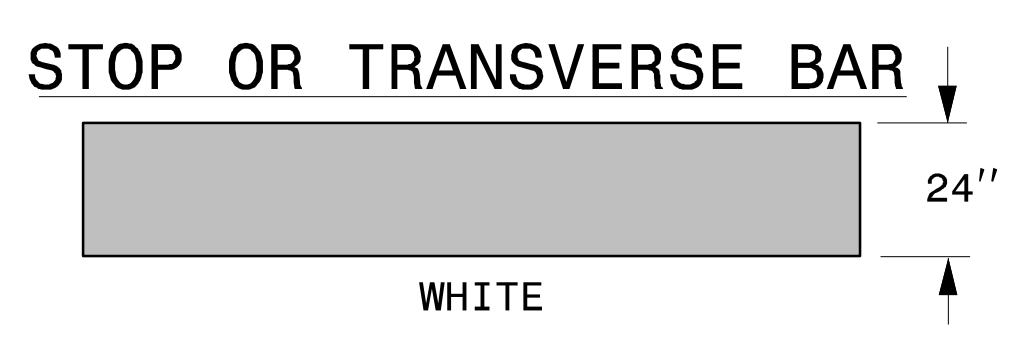
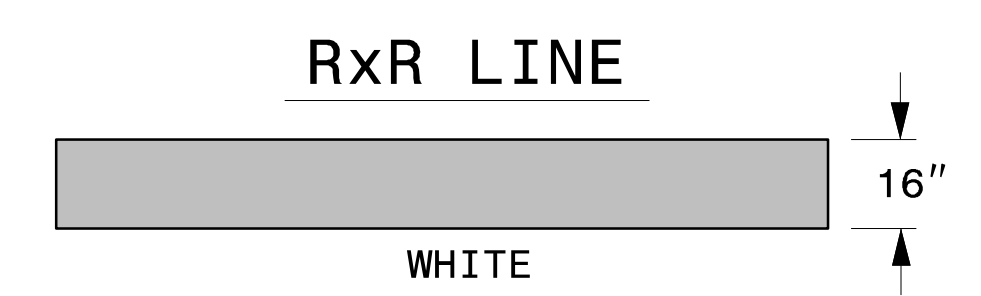
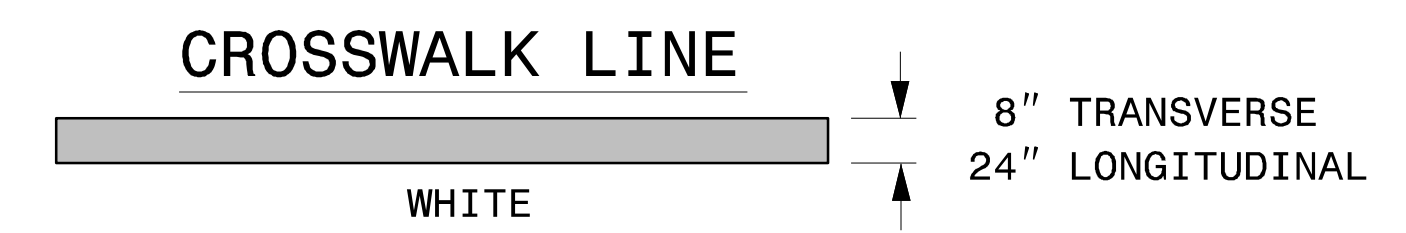
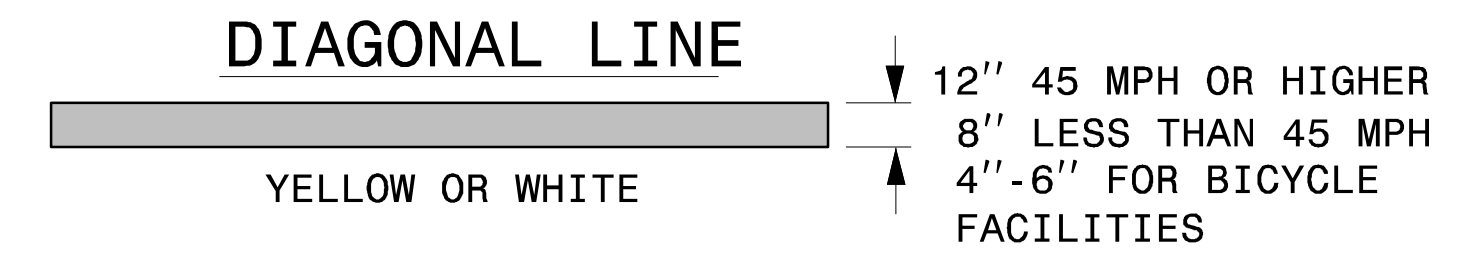
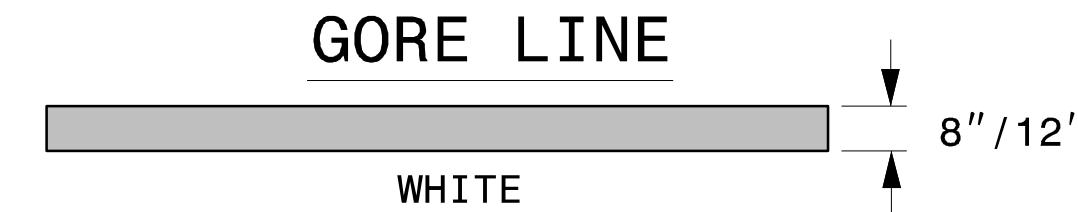
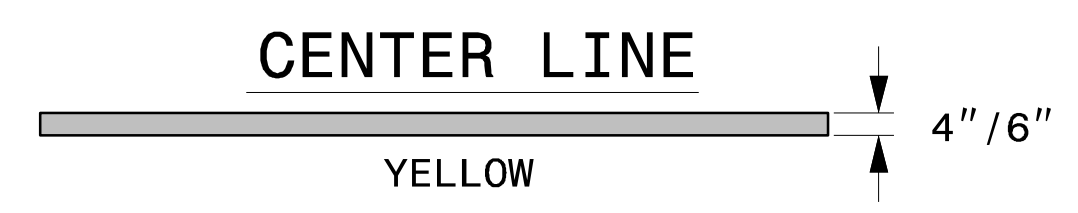
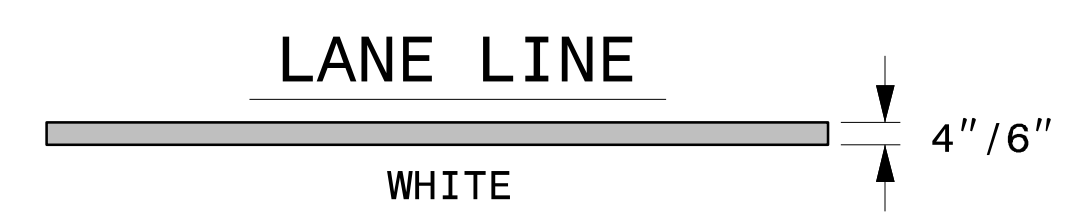
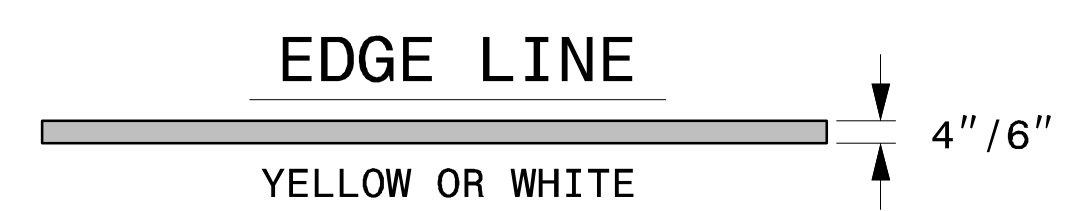

**10'-30'/SP SKIP LINE**

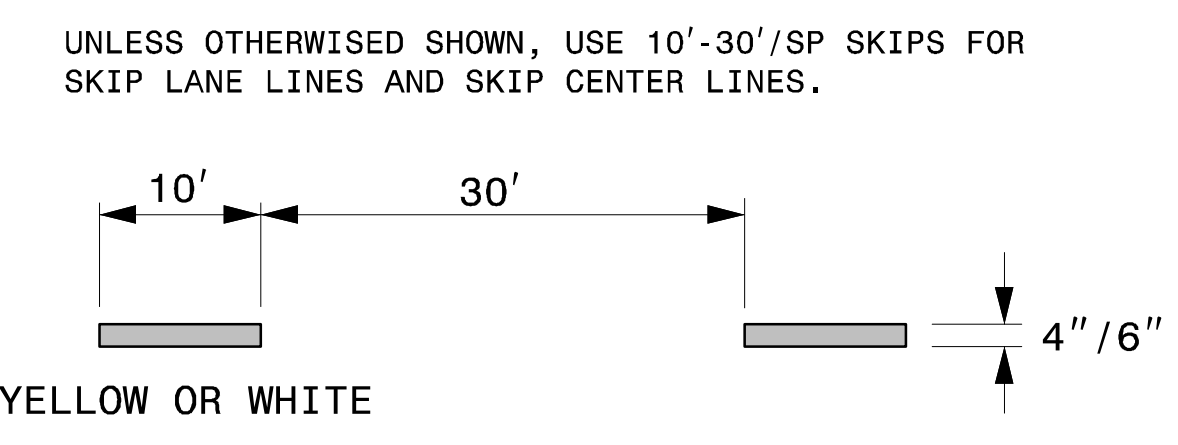

**2'-6'/SP MINI-SKIP LINE**

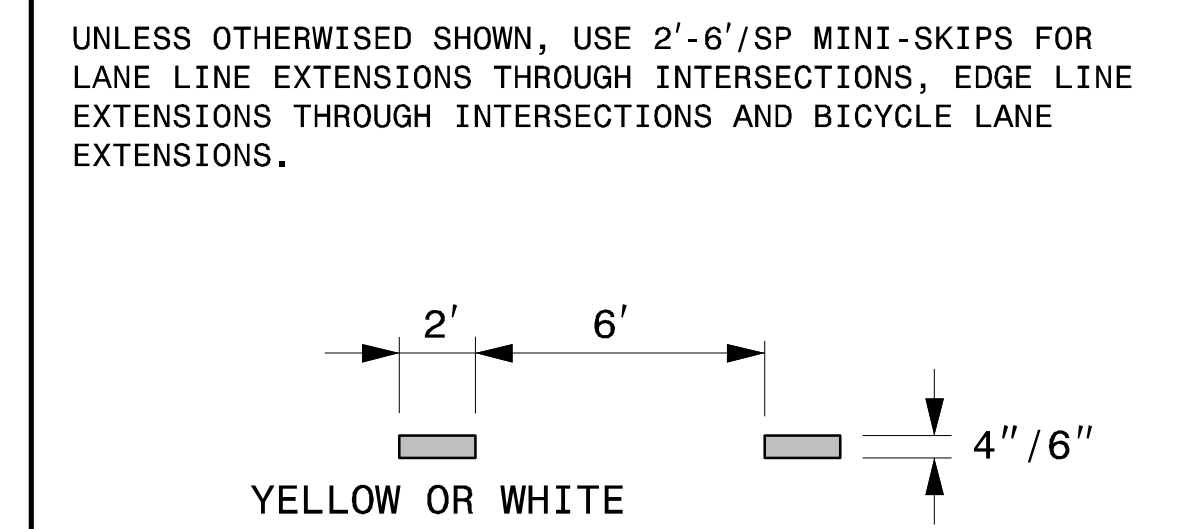

**3'-3'/SP MINI-SKIP LINE**

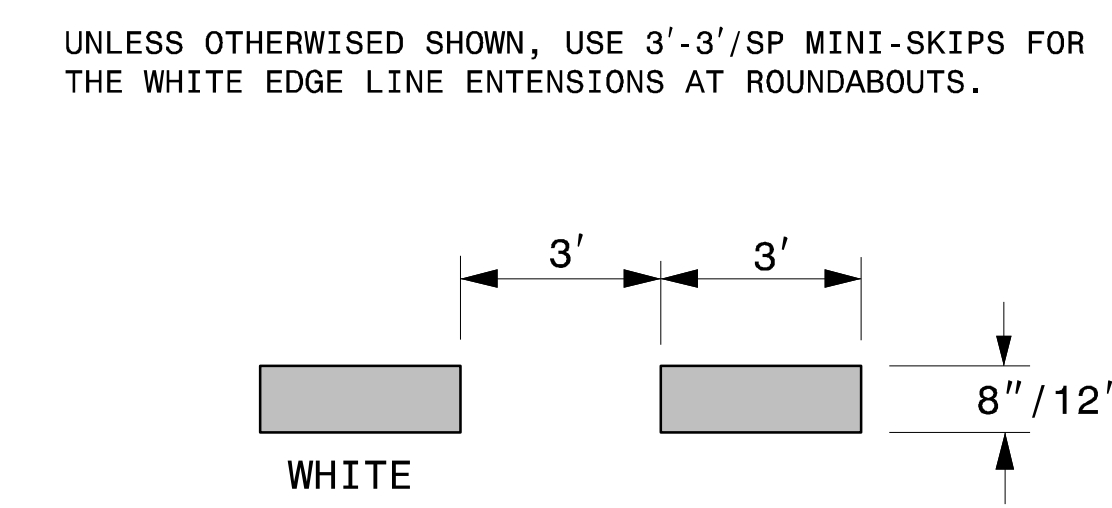

**3'-9'/SP MINI-SKIP LINE**

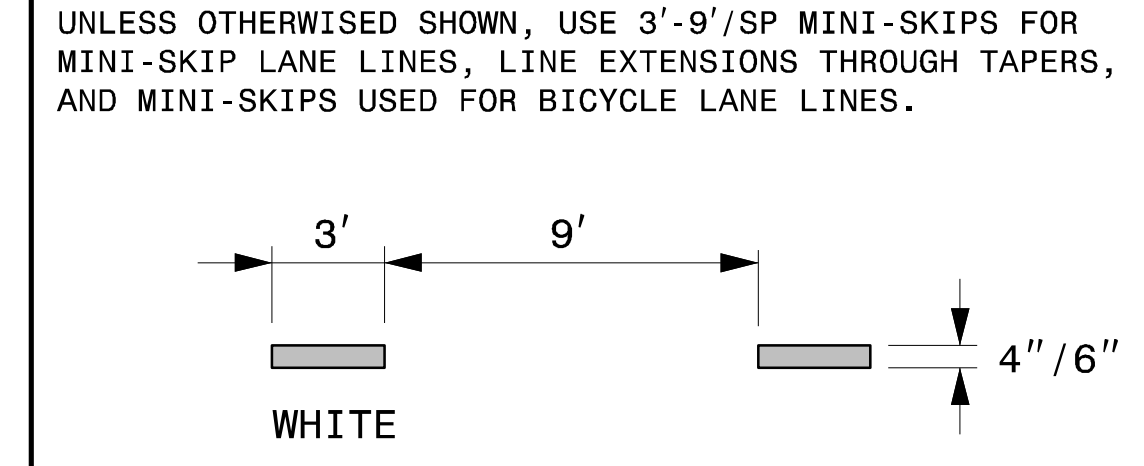

GENERAL NOTES:

- 1- USE 6" LANE, EDGE, AND CENTER LINES ON ALL FULL CONTROL OF ACCESS FACILITIES AND OTHER ROUTES AS DIRECTED BY THE ENGINEER.
- 2- LANE LINES INDICATED AS "WIDE" ON THE ROADWAY STANDARD DRAWINGS SHALL BE AT LEAST TWICE THE WIDTH OF THE NORMAL LINE.
- 3- GORE LINES SHALL BE TWICE THE WIDTH OF THE NORMAL LINE.

STATE OF NORTH CAROLINA  
DEPT. OF TRANSPORTATION  
DIVISION OF HIGHWAYS  
RALEIGH, N.C.

ROADWAY DETAIL DRAWING FOR  
**PAVEMENT MARKINGS**  
LINE TYPES AND OFFSETS

SHEET 1 OF 2  
**1205D01**

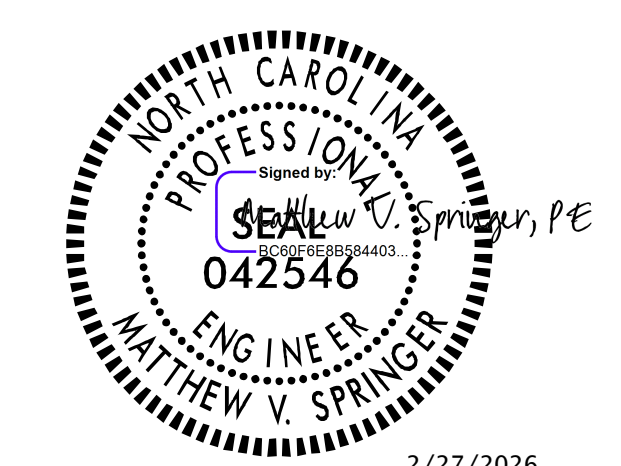

2/27/2026

**CONTRACTS STANDARDS AND DEVELOPMENT UNIT**  
Office 919-707-8950 FAX 919-250-4119

**SEE TITLE BLOCK**

ORIGINAL BY: M.V. SPRINGER DATE: 2-15-24  
MODIFIED BY: \_\_\_\_\_ DATE: \_\_\_\_\_  
CHECKED BY: \_\_\_\_\_ DATE: \_\_\_\_\_  
FILE SPEC.: \_\_\_\_\_

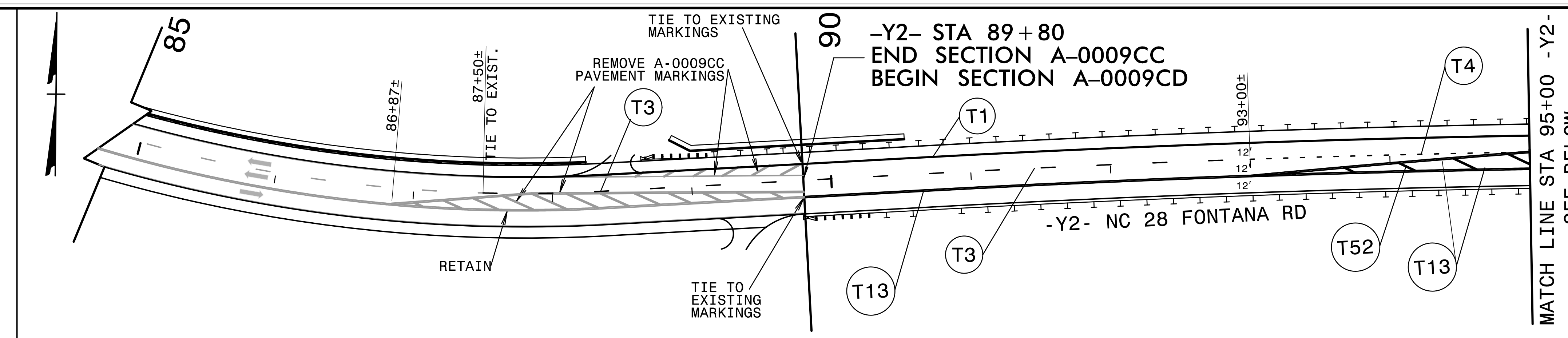

TIP NO. A-0009CD	SHEET NO. PMP-2
APPROVED: <i>Jimmy Terry</i> 2/27/2026	
DATE: 2/27/2026	
SEAL 	
DOCUMENT NOT CONSIDERED FINAL UNLESS ALL SIGNATURES COMPLETED	
TGS ENGINEERS 201 W. MARION ST., STE 200 SHELBY, NC 28150 PH: (704) 476-0003 CORP. LICENSE NO.: C-0275	

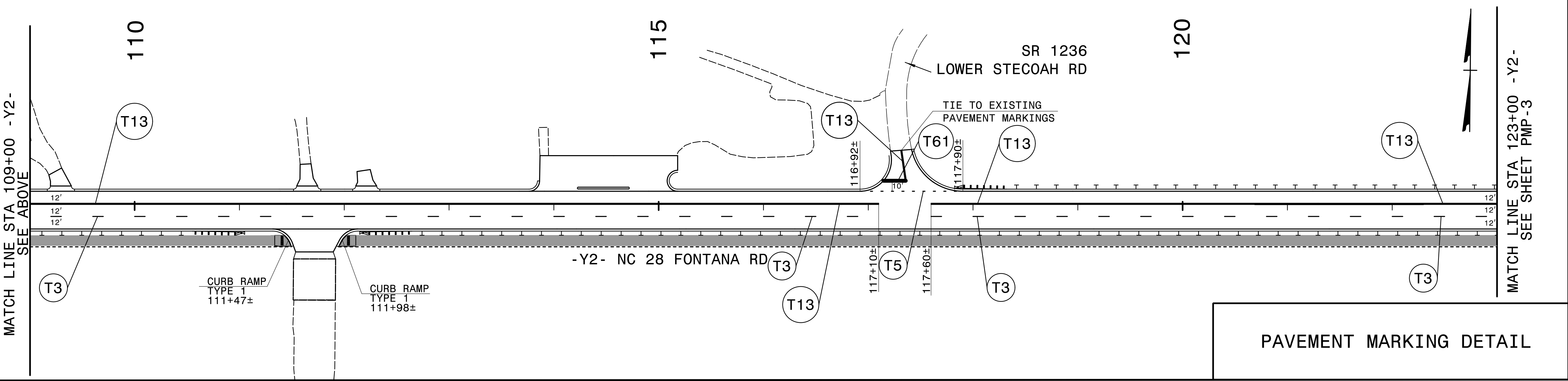
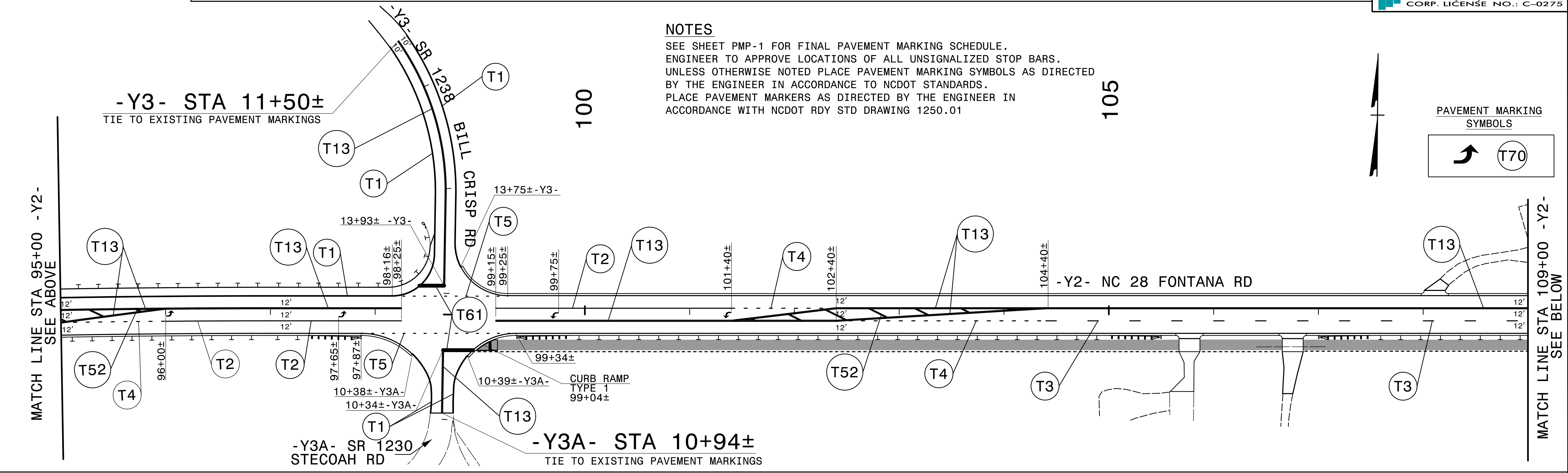
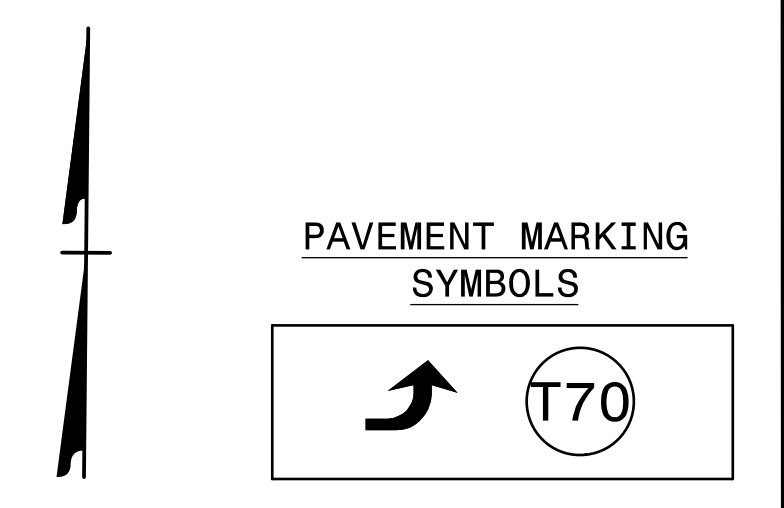

**NOTES**

SEE SHEET PMP-1 FOR FINAL PAVEMENT MARKING SCHEDULE.  
ENGINEER TO APPROVE LOCATIONS OF ALL UNSIGNALIZED STOP BARS.  
UNLESS OTHERWISE NOTED PLACE PAVEMENT MARKING SYMBOLS AS DIRECTED  
BY THE ENGINEER IN ACCORDANCE TO NCDOT STANDARDS.  
PLACE PAVEMENT MARKERS AS DIRECTED BY THE ENGINEER IN  
ACCORDANCE WITH NCDOT RDY STD DRAWING 1250.01



**PAVEMENT MARKING DETAIL**

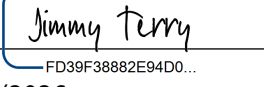

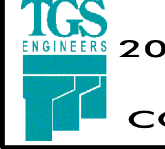
I:\2025\12\31\2025\A-0009CD\Traffic\ Pavement Markings\A-0009CD\A-0009CD\_Sgn\_PMP\_02.dgn  
User: smelvin

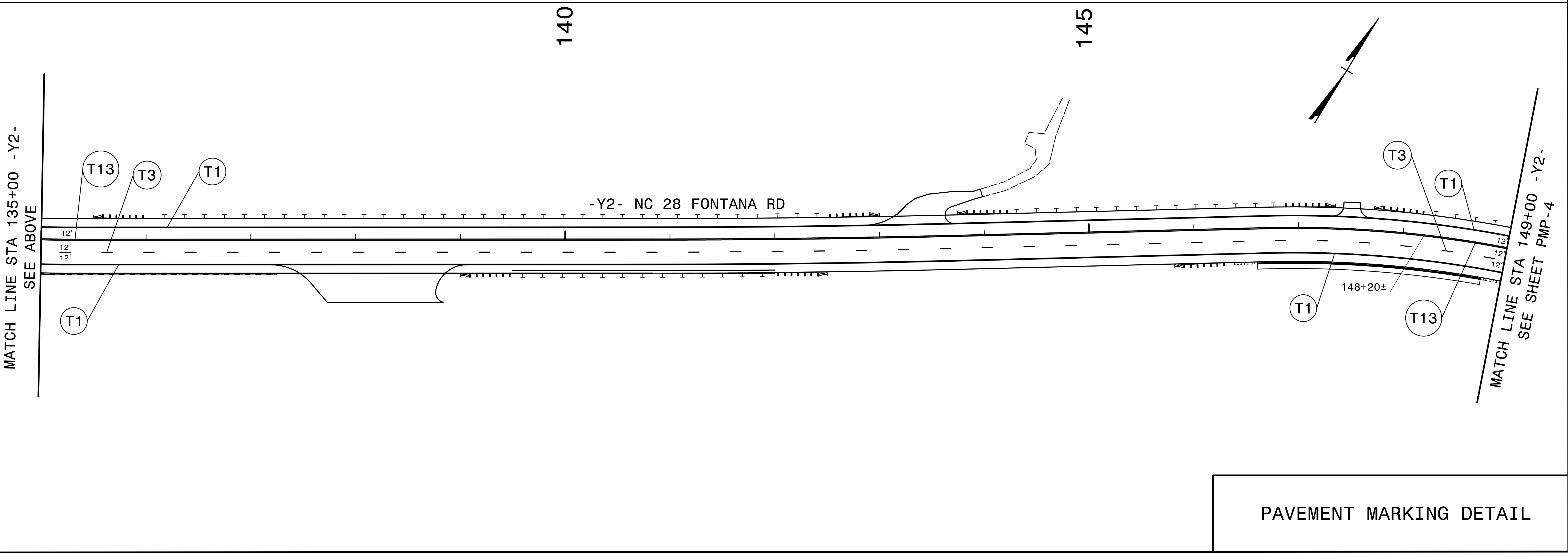
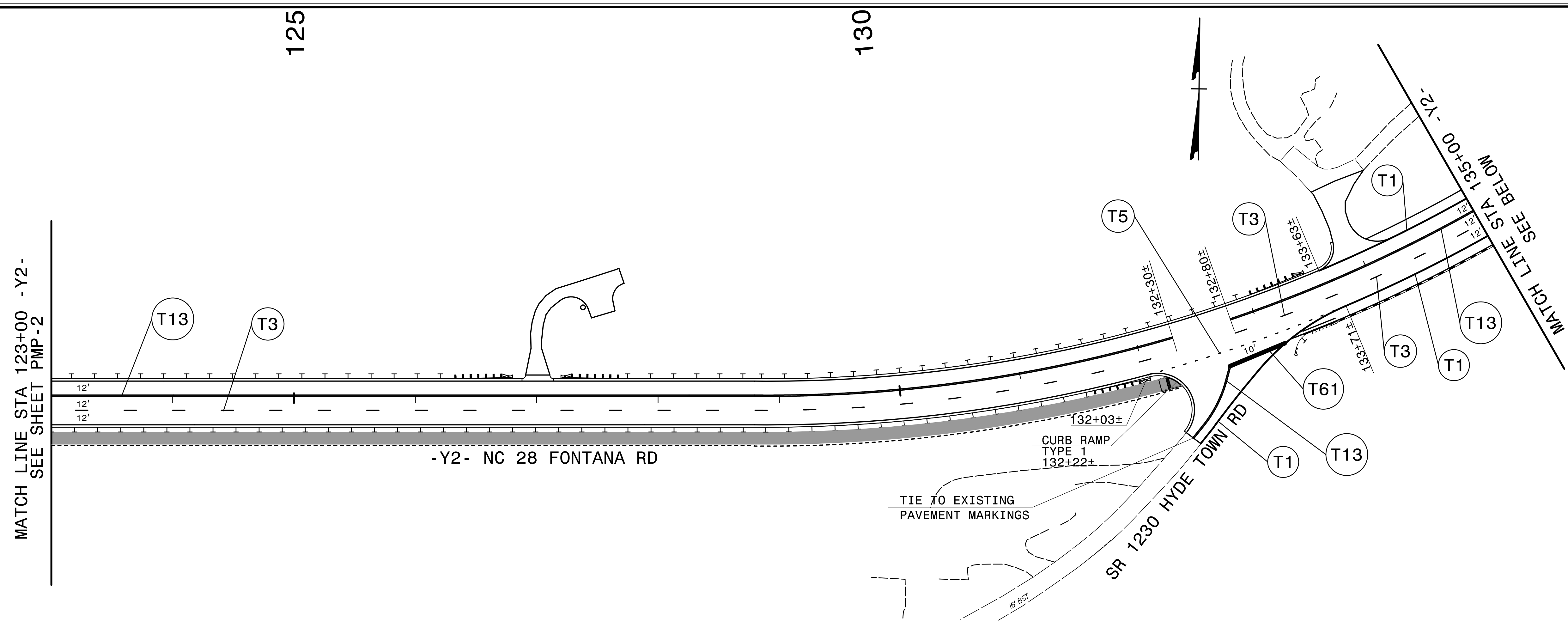
TIP NO. A-0009CD	SHEET NO. PMP-3
APPROVED: 	
DATE: 2/27/2026	
SEAL	
	
<b>DOCUMENT NOT CONSIDERED FINAL UNLESS ALL SIGNATURES COMPLETED</b>	
 <b>TGS ENGINEERS</b> 201 W. MARION ST., STE 200 SHELBY, NC 28150 PH: (704) 476-0003 CORP. LICENSE NO.: C-0275	

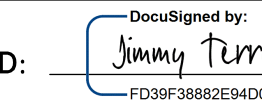

PAVEMENT MARKING DETAIL

I:\2025\12\31\2025\X:\NC001\A-0009CD\Traffic\Pavement Markings\A-0009CD\A-0009CD\_Sgn\_PMP\_03.dgn  
User:smelvin

TIP NO. A-0009CD	SHEET NO. PMP-4
APPROVED:  DATE: 2/27/2026	
SEAL 	
DOCUMENT NOT CONSIDERED FINAL UNLESS ALL SIGNATURES COMPLETED	
 TGS ENGINEERS 201 W. MARION ST., STE 200 SHELBY, NC 28150 PH (704) 476-0003 CORP. LICENSE NO.: C-0275	

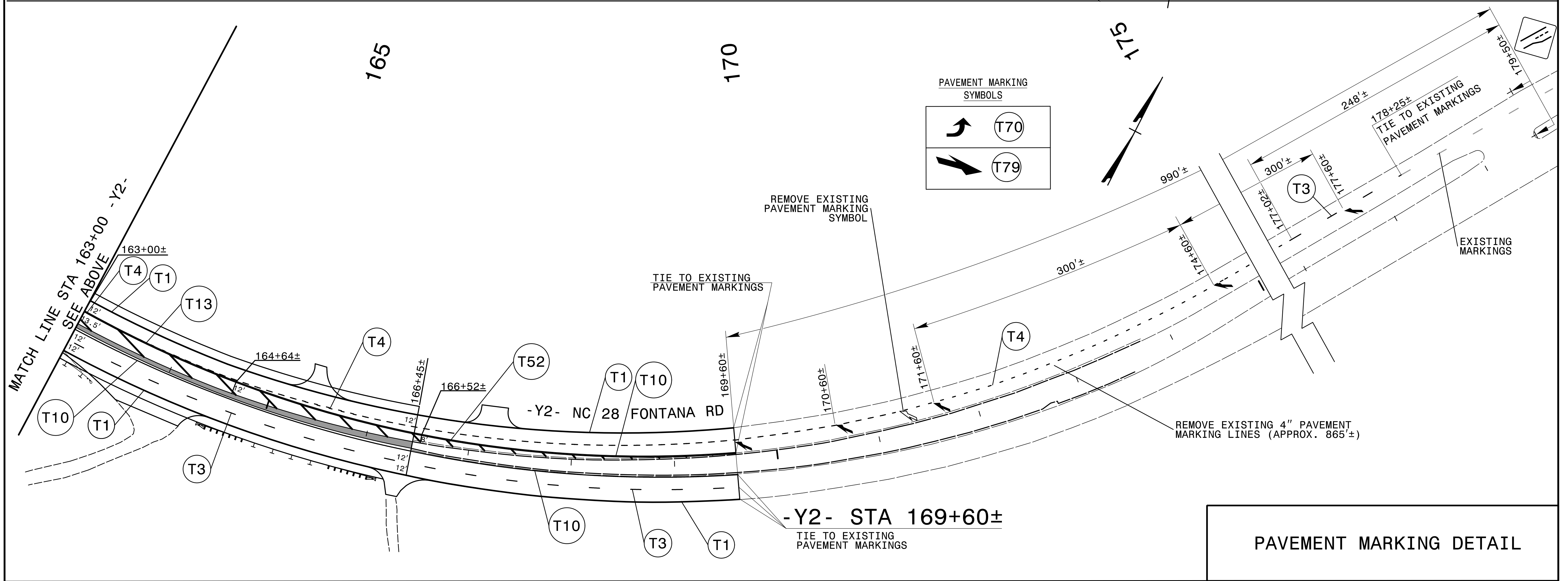
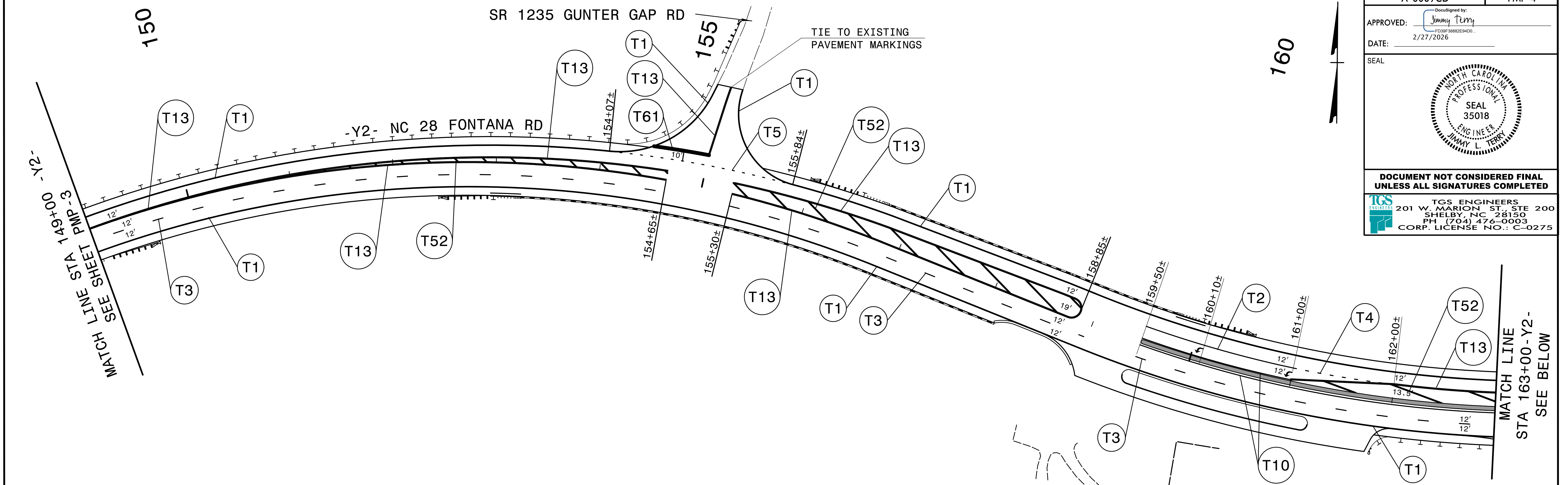

I:\4\2026\A-0009\Traffic\ Pavement Markings\A-0009CD\A-0009CD\_Sgn\_PMP\_04.dgn  
User:smelvin

PAVEMENT MARKING DETAIL