

STATE OF NORTH CAROLINA  
DIVISION OF HIGHWAYS

**TRANSPORTATION MANAGEMENT PLAN**

**GRAHAM COUNTY**  
DIVISION 14

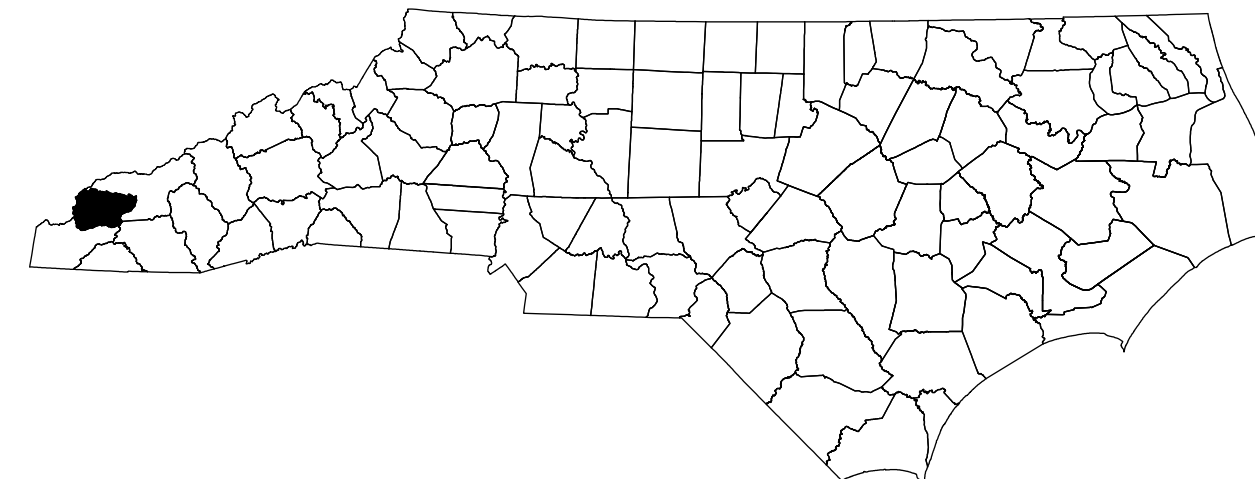

**NC 28 FROM 0.2 MI WEST OF SR 1228 (STECOAH RD)  
TO 0.3 MI EAST OF SR 1235 (GUNTER GAP RD)**

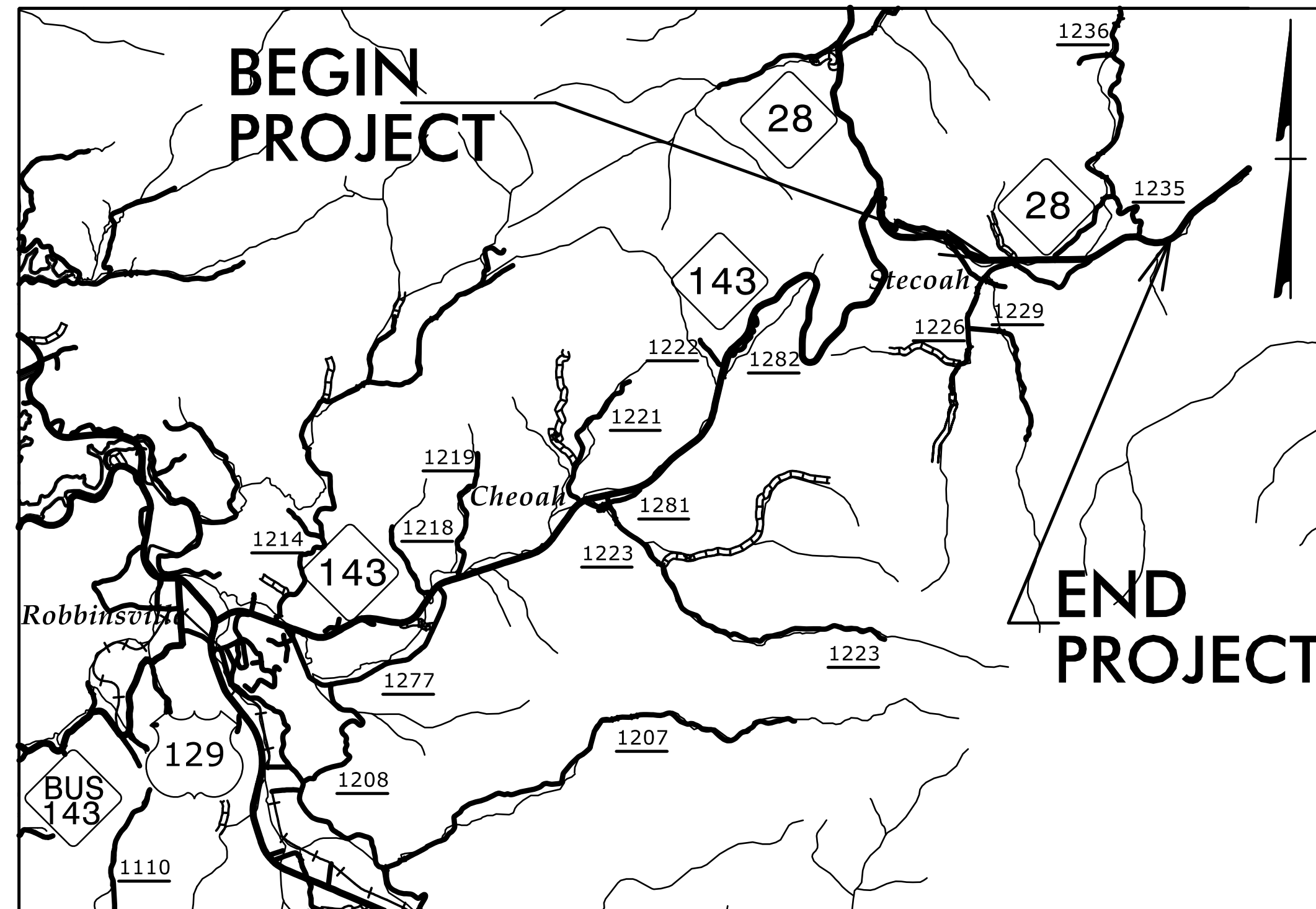

**VICINITY MAP**

**TYPE OF WORK: GRADING, PAVING, DRAINAGE, CULVERTS, & RETAINING WALLS**

**INDEX OF SHEETS**

| SHEET NO.             | TITLE   |
|-----------------------|---|
| TMP-1                 | TITLE SHEET, VICINITY MAP, AND INDEX OF SHEETS                            |
| TMP-1A                | LIST OF APPLICABLE ROADWAY STANDARD DRAWINGS, AND LEGEND                  |
| TMP-1B                | TRANSPORTATION OPERATIONS PLAN: (MANAGEMENT STRATEGIES AND GENERAL NOTES) |
| TMP-2                 | PORTABLE CONCRETE BARRIER AT TEMPORARY SHORING LOCATIONS                  |
| TMP-2A                | TEMPORARY SHORING DATA  |
| TMP-2B                | SPECIAL SIGN  |
| TMP-2C                | REVISED ROADWAY STANDARD DRAWING 1205D01 (SHT 1 OF 2)                     |
| TMP-3                 | TEMPORARY TRAFFIC CONTROL PHASING   |
| TMP-4<br>THRU TMP-6   | PHASE I   |
| TMP-7                 | PHASE I DETAIL  |
| TMP-8                 | PHASE II STEP 1   |
| TMP-9                 | PHASE II STEP 1 DETAIL  |
| TMP-10                | PHASE II STEP 1 DETAIL<br>OFF-SITE DETOUR - STECOAH RD                    |
| TMP-11<br>THRU TMP-14 | PHASE II STEP 2   |
| TMP-15<br>& TMP-16    | PHASE III   |

SHEET NO.  
TMP-1

**TIP PROJECT: A-0009CD**

**DOCUMENT NOT CONSIDERED FINAL  
UNLESS ALL SIGNATURES COMPLETED**

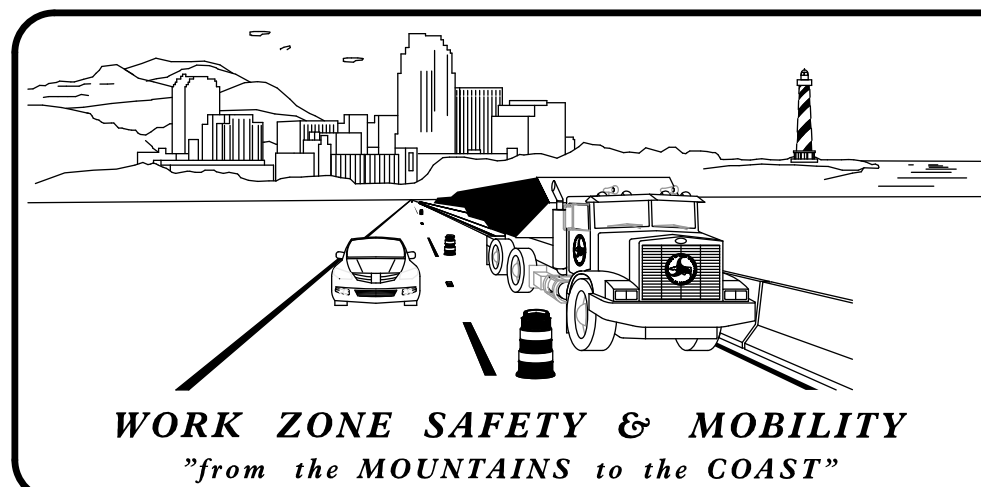

**PLANS PREPARED BY:**  
  
 JIMMY TERRY, PE  
PROJECT ENGINEER  
  
 SANDRA MELVIN  
DESIGN ENGINEER

**NCDOT CONTACTS:**  
  
 JEANETTE WHITE, PE

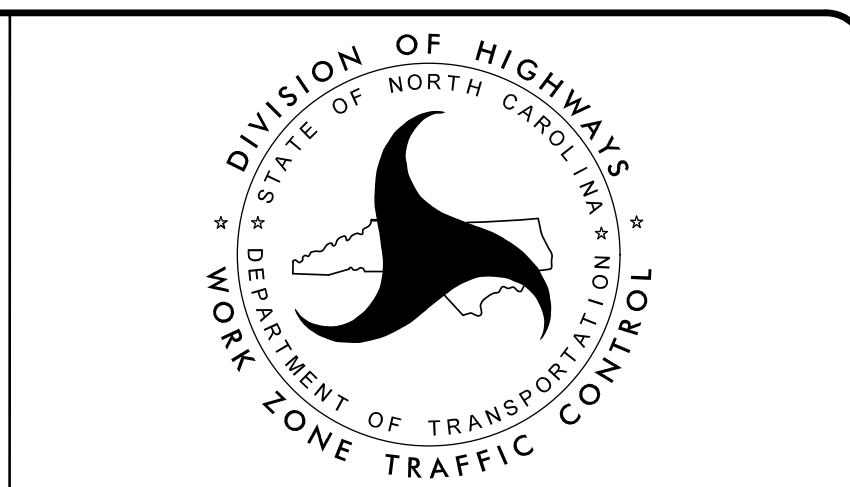

PLAN PREPARED FOR N.C.D.O.T. BY:  
 TGS ENGINEERS  
 201 W. MARION ST  
 SHELBY, NC 28150  
 PH (704) 476-0003  
 CORP. LICENSE NO.: C-0275

APPROVED: Jimmy Terry  
 DATE: 2/27/2026  
  
 SEAL

I:\22\2026\K:\NC\09\A-0009\Traffic\TrafficControl\TCP\A-0009CD\A-0009CD.TC.TMP\_01.dgn  
 User: smelvin

# ROADWAY STANDARD DRAWINGS

THE FOLLOWING ROADWAY STANDARDS AS SHOWN IN "ROADWAY STANDARD DRAWINGS" - N.C. DEPARTMENT OF TRANSPORTATION - RALEIGH, N.C., DATED JANUARY 2024 ARE APPLICABLE TO THIS PROJECT AND BY REFERENCE HEREBY ARE CONSIDERED A PART OF THESE PLANS:

| STD. NO. | TITLE  |
|----------|--|
| 1101.01  | WORK ZONE WARNING SIGNS                                  |
| 1101.02  | TEMPORARY LANE CLOSURES                                  |
| 1101.03  | TEMPORARY ROAD CLOSURES                                  |
| 1101.04  | TEMPORARY SHOULDER CLOSURES                              |
| 1101.05  | WORK ZONE VEHICLE ACCESSES                               |
| 1101.06  | WARNING SIGNS FOR BLASTING ZONES                         |
| 1101.11  | TRAFFIC CONTROL DESIGN TABLES                            |
| 1110.01  | STATIONARY WORK ZONE SIGNS                               |
| 1110.02  | PORTABLE WORK ZONE SIGNS                                 |
| 1130.01  | DRUMS  |
| 1135.01  | CONES  |
| 1145.01  | BARRICADES   |
| 1150.01  | FLAGGERS   |
| 1160.01  | TEMPORARY CRASH CUSHION                                  |
| 1165.01  | TRUCK MOUNTED ATTENUATOR                                 |
| 1170.01  | PORTABLE CONCRETE BARRIER                                |
| 1180.01  | SKINNY - DRUMS   |
| 1205.01  | PAVEMENT MARKINGS - LINE TYPES AND OFFSETS               |
| 1205.02  | PAVEMENT MARKINGS - TWO LANE AND MULTILANE ROADWAYS      |
| 1205.04  | PAVEMENT MARKINGS - INTERSECTIONS                        |
| 1205.09  | PAVEMENT MARKINGS - PAINTED ISLANDS                      |
| 1250.01  | RAISED PAVEMENT MARKERS - INSTALLATION SPACING           |
| 1251.01  | RAISED PAVEMENT MARKERS - (PERMANENT AND TEMPORARY)      |
| 1261.01  | GUARDRAIL AND BARRIER DELINEATORS - INSTALLATION SPACING |
| 1261.02  | GUARDRAIL AND BARRIER DELINEATORS - TYPES AND MOUNTING   |
| 1262.01  | GUARDRAIL END DELINEATION                                |

# LEGEND

## GENERAL

- DIRECTION OF TRAFFIC FLOW
- EXIST. PVMT.
- NORTH ARROW
- PROPOSED PVMT.
- TEMP. SHORING (LOCATION PURPOSES ONLY)
- WORK AREA
- REMOVAL
- WEDGING
- TEMPORARY PAVEMENT

## TRAFFIC CONTROL DEVICES

- BARRICADE (TYPE III)
- DRUM
- TEMPORARY CRASH CUSHION

## TEMPORARY SIGNING

- PORTABLE SIGN
- STATIONARY SIGN

## PAVEMENT MARKINGS

- EXISTING LINES
- TEMPORARY LINES

## TEMPORARY PAVEMENT MARKING

| SYMBOL            | DESCRIPTION                     | SYMBOL            | DESCRIPTION                                  |
|-------------------|---------------------------------|-------------------|--|
| PAVEMENT MARKINGS |                                 | PAVEMENT MARKINGS |  |
| PAINT (4")        |                                 | PAINT (24")       |  |
| P1                | (4") WHITE EDGELINE             | P61               | (24") WHITE STOPBAR                          |
| P5                | (4") 2FT.-6FT/SP WHITE MINISKIP |                   |  |
| P10               | (4") YELLOW EDGELINE            | PAVEMENT MARKERS  |  |
| P13               | (4") YELLOW DOUBLE CENTER       | MM                | TEMPORARY RAISED MARKERS (CRYSTAL & CRYSTAL) |

I:\22\2024\KAC\CD\A-0009\Traffic\TrafficControl\TCP\A-0009CD\A-0009CD-TC-TMP-01A.dgn  
 User: jsmelvin

|   |  |  |                                    |
|---|--|--|------------------------------------|
| APPROVED:<br>DATE: 2/27/2026<br>SEAL                          |  |  | ROADWAY STANDARD DRAWINGS & LEGEND |
| DOCUMENT NOT CONSIDERED FINAL UNLESS ALL SIGNATURES COMPLETED |  |  |                                    |

# GENERAL NOTES

|                     |           |
|---------------------|-----------|
| PROJ. REFERENCE NO. | SHEET NO. |
| A-0009CD            | TMP-1B    |

CHANGES MAY BE REQUIRED WHEN PHYSICAL DIMENSIONS IN THE DETAIL DRAWINGS, STANDARD DETAILS, AND ROADWAY DETAILS ARE NOT ATTAINABLE TO MEET FIELD CONDITIONS OR RESULT IN DUPLICATE OR UNDESIRE OVERLAPPING OF DEVICES. MODIFICATION MAY INCLUDE: MOVING, SUPPLEMENTING, COVERING, OR REMOVAL OF DEVICES AS DIRECTED BY THE ENGINEER.

THE FOLLOWING GENERAL NOTES APPLY AT ALL TIMES FOR THE DURATION OF THE CONSTRUCTION PROJECT EXCEPT WHEN OTHERWISE NOTED IN THE PLAN OR DIRECTED BY THE ENGINEER.

### TIME RESTRICTIONS

A) DO NOT CLOSE OR NARROW TRAVEL LANES DURING HOLIDAYS AND SPECIAL EVENTS AS FOLLOWS:

#### ROAD NAME

NC 28 (-Y2-)  
ANY OTHER ROAD

#### HOLIDAY

- FOR ANY UNEXPECTED OCCURRENCE THAT CREATES UNUSUALLY HIGH TRAFFIC VOLUMES, AS DIRECTED BY THE ENGINEER.
- FOR NEW YEAR'S, BETWEEN THE HOURS OF 4:00 P.M. DECEMBER 31st TO 9:00 A.M. JANUARY 2ND. IF NEW YEAR'S DAY IS ON A FRIDAY, SATURDAY, SUNDAY, OR MONDAY THEN UNTIL 9:00 A.M. THE FOLLOWING TUESDAY.
- FOR EASTER, BETWEEN THE HOURS OF 4:00 P.M. THURSDAY AND 9:00 A.M. MONDAY.
- FOR MEMORIAL DAY, BETWEEN THE HOURS OF 4:00 P.M. FRIDAY TO 9:00 A.M. TUESDAY.
- FOR INDEPENDENCE DAY, BETWEEN THE HOURS OF 4:00 P.M. THE DAY BEFORE INDEPENDENCE DAY AND 9:00 A.M. THE DAY AFTER INDEPENDENCE DAY.  
  
IF INDEPENDENCE DAY IS ON A FRIDAY, SATURDAY, SUNDAY OR MONDAY THEN BETWEEN THE HOURS OF 4:00 P.M. THE THURSDAY BEFORE INDEPENDENCE DAY AND 9:00 A.M. THE TUESDAY AFTER INDEPENDENCE DAY.
- FOR LABOR DAY, BETWEEN THE HOURS OF 4:00 P.M. FRIDAY AND 9:00 A.M. TUESDAY.
- FOR THANKSGIVING DAY, BETWEEN THE HOURS OF 4:00 P.M. TUESDAY TO 9:00 A.M. MONDAY.
- FOR CHRISTMAS, BETWEEN THE HOURS OF 4:00 P.M. THE FRIDAY BEFORE THE WEEK OF CHRISTMAS DAY AND 9:00 A.M. THE FOLLOWING TUESDAY AFTER THE WEEK OF CHRISTMAS.

B) DO NOT STOP TRAFFIC AS FOLLOWS:

| ROAD NAME    | DAY AND TIME RESTRICTIONS  | DURATION AND OPERATION          |
|--------------|--|---------------------------------|
| NC 28 (-Y2-) | MONDAY THRU SUNDAY<br>12:00 AM TO 8:00 AM<br>AND 4:00 PM TO 11:59 PM | 20 MINUTES FOR<br>ROCK BLASTING |

### LANE AND SHOULDER CLOSURE REQUIREMENTS

- C) REMOVE LANE CLOSURE DEVICES FROM THE LANE WHEN WORK IS NOT BEING PERFORMED BEHIND THE LANE CLOSURE OR WHEN A LANE CLOSURE IS NO LONGER NEEDED OR AS DIRECTED BY THE ENGINEER.
- D) WHEN PERSONNEL AND/OR EQUIPMENT ARE WORKING WITHIN 15 FT OF AN OPEN TRAVEL LANE, CLOSE THE NEAREST OPEN SHOULDER USING ROADWAY STANDARD DRAWING NO. 1101.04 UNLESS THE WORK AREA IS PROTECTED BY BARRIER OR GUARDRAIL OR A LANE CLOSURE IS INSTALLED.
- E) WHEN PERSONNEL AND/OR EQUIPMENT ARE WORKING WITHIN 5 FT OF AN OPEN TRAVEL LANE ON AN UNDIVIDED FACILITY, CLOSE THE NEAREST OPEN TRAVEL LANE USING ROADWAY STANDARD DRAWING NO. 1101.02 UNLESS THE WORK AREA IS PROTECTED BY BARRIER OR GUARDRAIL.  
  
WHEN PERSONNEL AND/OR EQUIPMENT ARE WORKING WITHIN 10 FT OF AN OPEN TRAVEL LANE ON A DIVIDED FACILITY, CLOSE THE NEAREST OPEN TRAVEL LANE USING ROADWAY STANDARD DRAWING NO. 1101.02 UNLESS THE WORK AREA IS PROTECTED BY BARRIER OR GUARDRAIL.
- F) WHEN PERSONNEL AND/OR EQUIPMENT ARE WORKING WITHIN A LANE OF TRAVEL OF AN UNDIVIDED OR DIVIDED FACILITY, CLOSE THE LANE ACCORDING TO THE TRAFFIC CONTROL PLANS, ROADWAY STANDARD DRAWINGS, OR AS DIRECTED BY THE ENGINEER. CONDUCT THE WORK SO THAT ALL PERSONNEL AND/OR EQUIPMENT REMAIN WITHIN THE CLOSED TRAVEL LANE.

- G) DO NOT WORK SIMULTANEOUSLY WITHIN 15 FT ON BOTH SIDES OF AN OPEN TRAVELWAY, RAMP, OR LOOP WITHIN THE SAME LOCATION UNLESS PROTECTED WITH GUARDRAIL OR BARRIER.
- H) PROVIDE TRAFFIC CONTROL FOR APPROPRIATE LANE CLOSURES FOR SURVEYING DONE BY THE DEPARTMENT.

### PAVEMENT EDGE DROP OFF REQUIREMENTS

- I) BACKFILL AT A 6:1 SLOPE UP TO THE EDGE AND ELEVATION OF EXISTING PAVEMENT IN AREAS ADJACENT TO AN OPENED TRAVEL LANE THAT HAS AN EDGE OF PAVEMENT DROP-OFF AS FOLLOWS:
- BACKFILL DROP-OFFS THAT EXCEED 2 INCHES ON ROADWAYS WITH POSTED SPEED LIMITS OF 45 MPH OR GREATER.
- BACKFILL DROP-OFFS THAT EXCEED 3 INCHES ON ROADWAYS WITH POSTED SPEED LIMITS LESS THAN 45 MPH.
- BACKFILL WITH SUITABLE COMPACTED MATERIAL, AS APPROVED BY THE ENGINEER, AT NO EXPENSE TO THE DEPARTMENT.
- J) DO NOT EXCEED A DIFFERENCE OF 2 INCHES IN ELEVATION BETWEEN OPEN LANES OF TRAFFIC FOR NOMINAL LIFTS OF 1.5 INCHES. INSTALL ADVANCE WARNING "UNEVEN LANES" SIGNS (W8-11) 250 FT IN ADVANCE AND A MINIMUM OF EVERY HALF MILE THROUGHOUT THE UNEVEN AREA.

### TRAFFIC PATTERN ALTERATIONS

- K) NOTIFY THE ENGINEER THIRTY (30) CALENDAR DAYS PRIOR TO ANY TRAFFIC PATTERN ALTERATION.

### SIGNING

- L) INSTALL ADVANCE WORK ZONE WARNING SIGNS WHEN WORK IS WITHIN 40 FT FROM THE EDGE OF TRAVEL LANE AND NO MORE THAN THREE (3) DAYS PRIOR TO THE BEGINNING OF CONSTRUCTION.
- M) PROVIDE SIGNING AND DEVICES REQUIRED TO CLOSE THE ROAD ACCORDING TO THE ROADWAY STANDARD DRAWINGS AND TRAFFIC CONTROL PLANS.  
  
PROVIDE SIGNING REQUIRED FOR THE OFF-SITE DETOUR ROUTE AS SHOWN IN THE TRAFFIC CONTROL PLANS.
- N) COVER OR REMOVE ALL SIGNS AND DEVICES REQUIRED TO CLOSE THE ROAD WHEN ROAD CLOSURE IS NOT IN OPERATION.  
  
COVER OR REMOVE ALL SIGNS REQUIRED FOR THE OFF-SITE DETOUR WHEN THE DETOUR IS NOT IN OPERATION.
- O) ENSURE ALL NECESSARY SIGNING IS IN PLACE PRIOR TO ALTERING ANY TRAFFIC PATTERN.
- P) INSTALL BLACK ON ORANGE "DIP" SIGNS (W8-2) AND/OR "BUMP" SIGNS (W8-1) 250 FT IN ADVANCE OF THE UNEVEN AREA, OR AS DIRECTED BY THE ENGINEER.

### TRAFFIC BARRIER

- Q) INSTALL TEMPORARY BARRIER ACCORDING TO THE TRANSPORTATION MANAGEMENT PLANS A MAXIMUM OF TWO (2) WEEKS PRIOR TO BEGINNING WORK IN ANY LOCATION. ONCE TEMPORARY BARRIER IS INSTALLED AT ANY LOCATION PROCEED IN A CONTINUOUS MANNER TO COMPLETE THE PROPOSED WORK IN THAT LOCATION UNLESS OTHERWISE STATED IN THE TRANSPORTATION MANAGEMENT PLANS OR AS DIRECTED BY THE ENGINEER.

DO NOT PLACE BARRIER DIRECTLY ON ANY SURFACE OTHER THAN ASPHALT OR CONCRETE.

ONCE TEMPORARY BARRIER IS INSTALLED AT ANY LOCATION AND NO WORK IS PERFORMED BEHIND THE TEMPORARY BARRIER FOR A PERIOD LONGER THAN TWO (2) MONTHS, REMOVE / RESET TEMPORARY BARRIER AT NO COST TO THE DEPARTMENT UNLESS OTHERWISE STATED IN THE TRANSPORTATION MANAGEMENT PLANS, TEMPORARY BARRIER IS PROTECTING A HAZARD, OR AS DIRECTED BY THE ENGINEER.

INSTALL TEMPORARY BARRIER WITH THE TRAFFIC FLOW BEGINNING WITH THE UPSTREAM SIDE OF TRAFFIC. REMOVE TEMPORARY BARRIER AGAINST THE TRAFFIC FLOW BEGINNING WITH THE DOWNSTREAM SIDE OF TRAFFIC.

INSTALL AND SPACE DRUMS NO GREATER THAN TWICE THE POSTED SPEED LIMIT (MPH) TO CLOSE OR KEEP THE SECTION OF THE ROADWAY CLOSED UNTIL THE TEMPORARY BARRIER CAN BE PLACED OR AFTER THE TEMPORARY BARRIER IS REMOVED.

- R) PROTECT THE APPROACH END OF MOVABLE/PORTABLE CONCRETE BARRIER AT ALL TIMES DURING THE INSTALLATION AND REMOVAL OF THE BARRIER BY EITHER A TRUCK MOUNTED ATTENUATOR (MAXIMUM 72 HOURS) OR A TEMPORARY CRASH CUSHION.

PROTECT THE APPROACH END OF MOVABLE/PORTABLE CONCRETE BARRIER FROM ONCOMING TRAFFIC AT ALL TIMES BY A TEMPORARY CRASH CUSHION UNLESS THE APPROACH END OF MOVABLE/PORTABLE CONCRETE BARRIER IS OFFSET FROM ONCOMING TRAFFIC AS FOLLOWS OR AS SHOWN IN THE PLANS: (SEE ALSO 1101.05)

| POSTED SPEED LIMIT | MINIMUM OFFSET |
|--------------------|----------------|
| 40 OR LESS         | 15 FT          |
| 45 - 50            | 20 FT          |
| 55                 | 25 FT          |
| 60 MPH or HIGHER   | 30 FT          |

### TRAFFIC CONTROL DEVICES

- S) WHEN LANE CLOSURES ARE NOT IN EFFECT SPACE CHANNELIZING DEVICES IN WORK AREAS NO GREATER IN FEET THAN TWICE THE POSTED SPEED LIMIT (MPH) EXCEPT, 10 FT ON-CENTER IN RADII, AND 3 FT OFF THE EDGE OF AN OPEN TRAVELWAY. REFER TO STANDARD SPECIFICATIONS FOR ROADS AND STRUCTURES SECTIONS 1130 (DRUMS), 1135 (CONES) AND 1180 (SKINNY DRUMS) FOR ADDITIONAL REQUIREMENTS.
- T) PLACE TYPE III BARRICADES, WITH "ROAD CLOSED" SIGN R11-2 ATTACHED, OF SUFFICIENT LENGTH TO CLOSE ENTIRE ROADWAY.
- U) PLACE ADDITIONAL SETS OF THREE CHANNELIZING DEVICES PERPENDICULAR TO THE EDGE OF TRAVELWAY ON 500 FT CENTERS WHEN UNOPENED LANES ARE CLOSED TO TRAFFIC.

### PAVEMENT MARKINGS AND MARKERS

- V) INSTALL TEMPORARY PAVEMENT MARKINGS AND TEMPORARY PAVEMENT MARKERS ON INTERIM LAYERS OF PAVEMENT AS FOLLOWS:

| ROAD NAME      | MARKING | MARKER           |
|----------------|---------|------------------|
| NC 28          | PAINT   | TEMPORARY RAISED |
| ANY OTHER ROAD | PAINT   | NONE             |

- W) INSTALL PAVEMENT MARKINGS AND PAVEMENT MARKERS ON THE FINAL SURFACE.
- X) PLACE ONE APPLICATION OF PAINT FOR TEMPORARY TRAFFIC PATTERNS. PLACE A SECOND APPLICATION OF PAINT SIX (6) MONTHS AFTER THE INITIAL APPLICATION AND EVERY SIX MONTHS AS DIRECTED BY THE ENGINEER.
- Y) TIE PROPOSED PAVEMENT MARKING LINES TO EXISTING PAVEMENT MARKING LINES.
- Z) REMOVE/REPLACE ANY CONFLICTING/DAMAGED PAVEMENT MARKINGS AND MARKERS BY THE END OF EACH DAY'S OPERATION.
- AA) ALL CURB RAMP LOCATIONS SHALL BE DERIVED FROM STATIONING SHOWN ON PAVEMENT MARKING PLANS OR AS DIRECTED BY THE ENGINEER IN COORDINATION WITH THE SIGNING AND DELINEATION UNIT.

## MANAGEMENT STRATEGIES

TRAFFIC MANAGEMENT STRATEGIES:  
FULL ROADWAY CLOSURES  
LANE SHIFTS OR CLOSURES  
SHOULDER CLOSURES  
ONE-LANE, TWO WAY OPERATION (FLAGGING)  
ON-SITE DETOURS

APPROVED: Jimmy Perry  
DATE: 2/27/2026

SEAL

DOCUMENT NOT CONSIDERED FINAL UNLESS ALL SIGNATURES COMPLETED

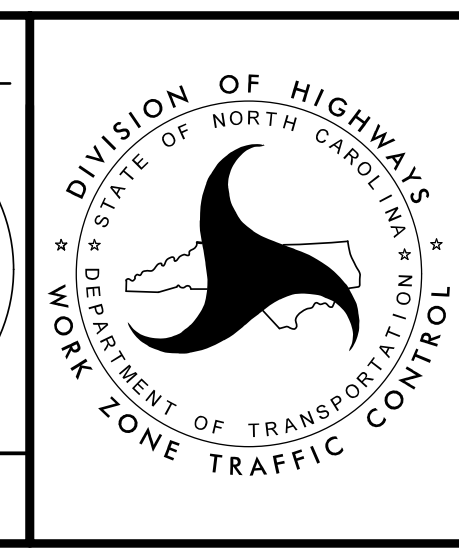

TRANSPORTATION OPERATIONS PLAN

V:\22\2026\A-0009\Traffic\TrafficControl\TCP\A-0009CD\A-0009CD-TC-TMP-01B.dgn  
 User: jsmelvin

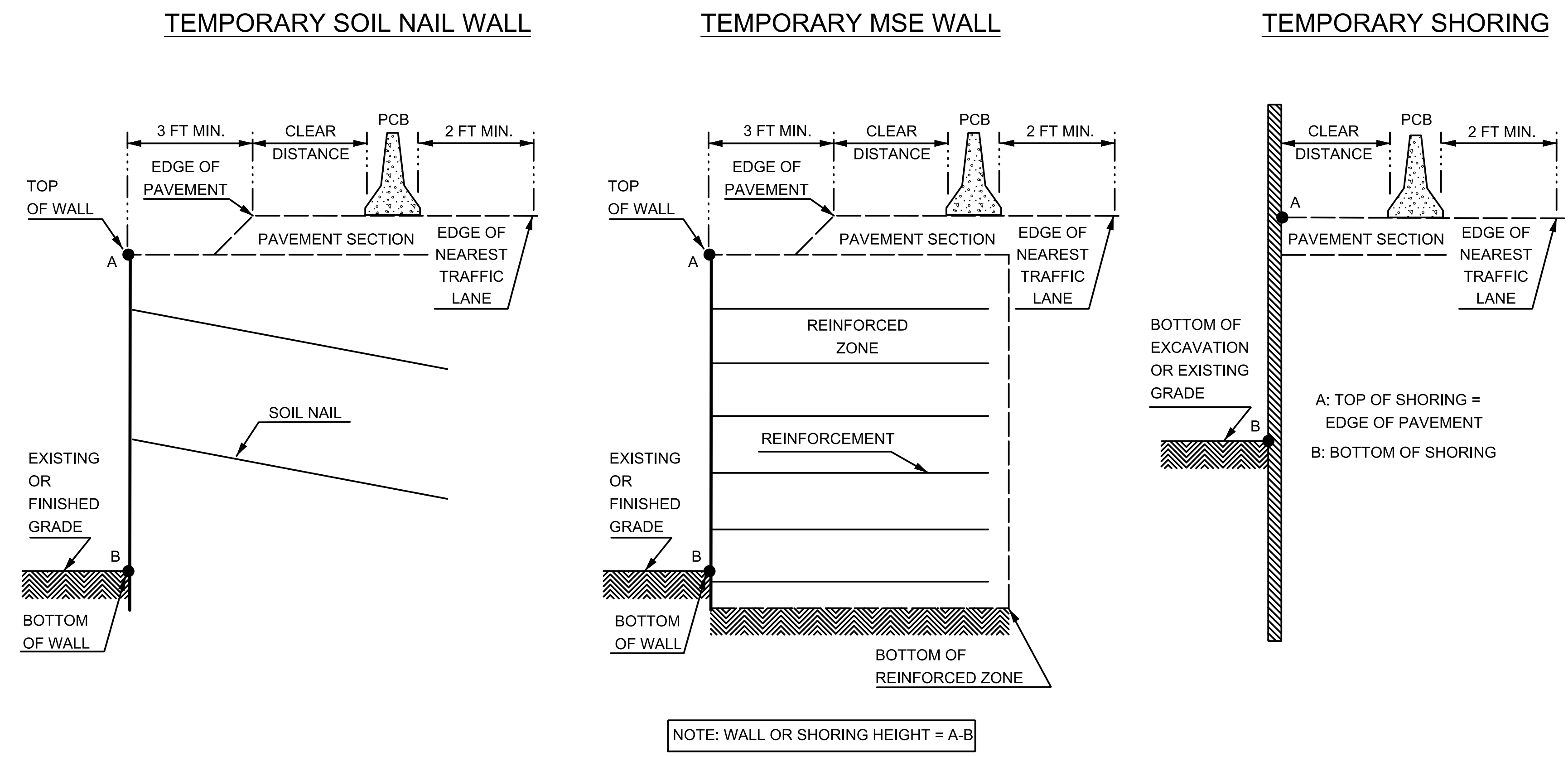

# FIGURE A

## NOTES

- 1- REFER TO THE TRAFFIC CONTROL PLANS FOR TEMPORARY SHORING LOCATIONS AND NOTES.
- 2- REFER TO THE "TEMPORARY SHORING" STANDARD PROVISION FOR INFORMATION ABOUT TEMPORARY SHORING AND PORTABLE CONCRETE BARRIER (PCB).
- 3- PCB IS REQUIRED IF TEMPORARY SHORING/WALL IS LOCATED WITHIN THE CLEAR ZONE IN ACCORDANCE WITH THE AASHTO ROADSIDE DESIGN GUIDE. DO NOT PLACE BARRIER DIRECTLY ON ANY SURFACE OTHER THAN ASPHALT OR CONCRETE. (CONTACT NCDOT PAVEMENT MANAGEMENT FOR APPLICABLE PAVEMENT DESIGN).
- 4- BASED ON THE CLEAR DISTANCE, OFFSET, DESIGN SPEED AND PAVEMENT TYPE, CHOOSE AN UNANCHORED OR ANCHORED PCB FROM THE TABLE SHOWN IN FIGURE B. CLEAR DISTANCE IS DEFINED AS SHOWN IN FIGURE A AND OFFSET IS DEFINED AS SHOWN IN FIGURE B.
- 5- AT THE CONTRACTOR'S OPTION OR IF THE MINIMUM REQUIRED CLEAR DISTANCE IS NOT AVAILABLE, SET PCB NEXT TO AND UP AGAINST THE TRAFFIC SIDE OF THE TEMPORARY SHORING/WALLS EXCEPT FOR BARRIER ABOVE TEMPORARY WALLS. PCB WITH THE MINIMUM REQUIRED CLEAR DISTANCE IS REQUIRED ABOVE TEMPORARY WALLS.
- 6- USE NCDOT PORTABLE CONCRETE BARRIER (PCB) IN ACCORDANCE WITH ROADWAY STANDARD DRAWING NO. 1170.01 AND SECTION 1170 OF THE STANDARD SPECIFICATIONS.
- 7- SET PCB WITH A MINIMUM HORIZONTAL DISTANCE OF 2 FT BETWEEN THE FRONT FACE OF THE BARRIER AND THE EDGE OF THE NEAREST TRAFFIC LANE AS SHOWN IN FIGURE A UNLESS OTHERWISE SHOWN IN THE PLANS OR APPROVED BY THE ENGINEER.
- 8- FOR PCB ABOVE AND BEHIND TEMPORARY WALLS, PROVIDE A MINIMUM DISTANCE OF 3 FT BETWEEN THE EDGE OF PAVEMENT AND THE WALL FACE AS SHOWN IN FIGURE A. IF THIS MINIMUM REQUIRED DISTANCE IS NOT AVAILABLE, CONTACT THE ENGINEER.
- 9- TABLE SHOWN IN FIGURE B IS BASED ON NCDOT RESEARCH PROJECT NO. 2005-010 WITH VEHICLE TYPE USED FOR NCHRP 350 CRASH TESTS.

**MINIMUM REQUIRED CLEAR DISTANCE, inches**

| Barrier Type   | Pavement Type                              | Offset *<br>ft | Design Speed, mph        |       |       |       |       |       |
|----------------|--|----------------|--------------------------|-------|-------|-------|-------|-------|
|                |  |                | <30                      | 31-40 | 41-50 | 51-60 | 61-70 | 71-80 |
| Unanchored PCB | Asphalt                                    | <8             | 24                       | 26    | 29    | 32    | 36    | 40    |
|                |  | 8-14           | 26                       | 28    | 31    | 35    | 38    | 42    |
|                |  | 14-20          | 27                       | 29    | 34    | 36    | 39    | 43    |
|                |  | 20-26          | 28                       | 31    | 35    | 38    | 40    | 44    |
|                |  | 26-32          | 29                       | 32    | 36    | 39    | 42    | 45    |
|                |  | 32-38          | 30                       | 34    | 38    | 41    | 43    | 46    |
|                |  | 38-44          | 31                       | 34    | 41    | 43    | 45    | 48    |
|                | 44-50                                      | 31             | 35                       | 41    | 43    | 46    | 49    |       |
|                | 50-56                                      | 32             | 36                       | 42    | 44    | 47    | 50    |       |
|                | >56  | 32             | 36                       | 42    | 45    | 47    | 51    |       |
|                | Concrete                                   | <8             | 17                       | 18    | 21    | 22    | 25    | 26    |
|                |  | 8-14           | 19                       | 20    | 23    | 25    | 26    | 29    |
|                |  | 14-20          | 22                       | 22    | 24    | 26    | 28    | 31    |
|                |  | 20-26          | 23                       | 24    | 26    | 27    | 30    | 34    |
| 26-32          |  | 24             | 25                       | 27    | 28    | 32    | 35    |       |
| 32-38          |  | 24             | 26                       | 27    | 30    | 33    | 36    |       |
| 38-44          |  | 25             | 26                       | 28    | 30    | 34    | 37    |       |
| 44-50          | 26   | 26             | 28                       | 32    | 35    | 37    |       |       |
| 50-56          | 26   | 26             | 28                       | 32    | 35    | 38    |       |       |
| >56            | 26   | 27             | 29                       | 32    | 36    | 38    |       |       |
| Anchored PCB   | Asphalt                                    | All Offsets    | 24 for All Design Speeds |       |       |       |       |       |
| Anchored PCB   | Concrete (including bridge approach slabs) | All Offsets    | 12 for All Design Speeds |       |       |       |       |       |

\* See Figure Below

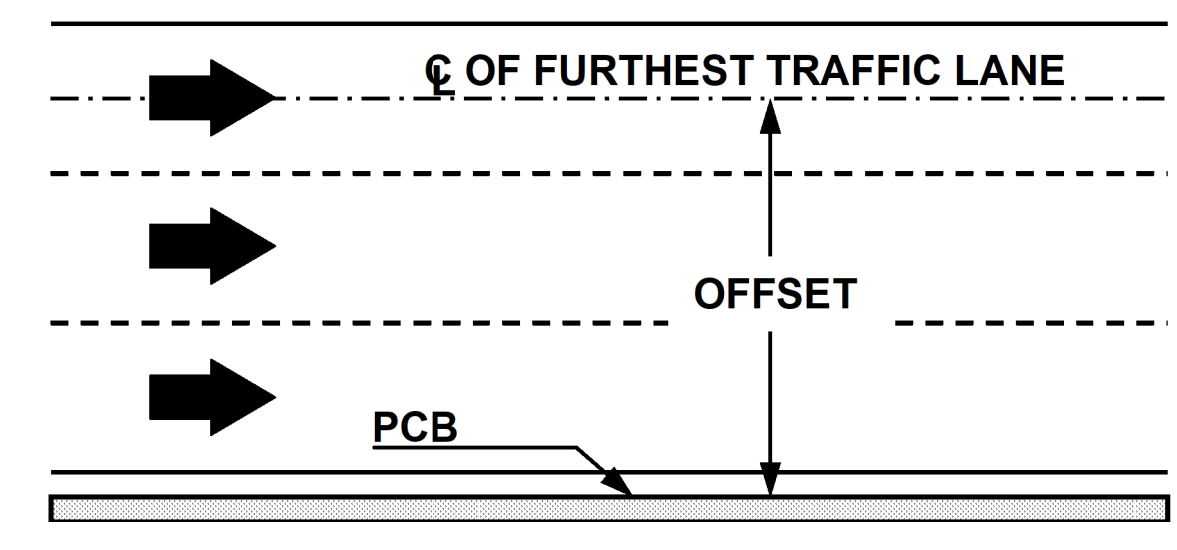

# FIGURE B

|  |  |  |  |
|--|--|--|--|
| APPROVED: <i>Jimmy Terry</i><br><small>FD39F3882E94D0</small><br>DATE: 2/27/2026<br>SEAL |  |  | PORTABLE CONCRETE BARRIER<br>AT<br>TEMPORARY SHORING LOCATIONS |
| <small>DOCUMENT NOT CONSIDERED FINAL UNLESS ALL SIGNATURES COMPLETED</small>             |  |  |  |

# TEMPORARY SHORING DATA

|                     |           |
|---------------------|-----------|
| PROJ. REFERENCE NO. | SHEET NO. |
| A-0009CD            | TMP-2A    |

Shoring Location No. 1:

FOR TEMPORARY SHORING AND POSITIVE PROTECTION FOR TEMPORARY SHORING, SEE PLANS AND TEMPORARY SHORING PROVISION.

TEMPORARY SHORING IS REQUIRED FOR THE STRUCTURE CONSTRUCTION FROM -Y2- STATION 99+58, 6.3' RT TO -Y2- STATION 100+08, 6.3' RT.

BEFORE BEGINNING TEMPORARY SHORING DESIGN OR CONSTRUCTION, SURVEY EXISTING GROUND ELEVATIONS IN THE VICINITY OF SHORING LOCATIONS TO DETERMINE ACTUAL SHORING HEIGHTS.

DESIGN TEMPORARY SHORING FROM -Y2- STATION 99+58, 6.3' RT TO -Y2- STATION 100+08, 6.3' RT, FOR THE FOLLOWING ASSUMED SOIL PARAMETERS AND GROUNDWATER ELEVATION:

- UNIT WEIGHT ( $\gamma$ ) = 120 LB/CF
- FRICTION ANGLE ( $\phi$ ) = 30 DEGREES
- COHESION (c) = 0 LB/SF
- GROUNDWATER ELEVATION = 2015 FT

DRIVEN PILING FOR TEMPORARY SHORING FROM -Y2- STATION 99+58, 6.3' RT TO -Y2- STATION 100+08, 6.3' RT MAY NOT PENETRATE BELOW ELEVATION 2010 FT DUE TO OBSTRUCTIONS, VERY DENSE OR HARD SOIL, BOULDERS OR WEATHERED OR HARD ROCK.

AT THE CONTRACTOR'S OPTION, USE STANDARD TEMPORARY SHORING FOR TEMPORARY SHORING FROM -Y2- STATION 99+58, 6.3' RT TO -Y2- STATION 100+08, 6.3' RT. SEE STANDARD DETAIL NO. 1801.01 FOR STANDARD TEMPORARY SHORING.

IT MAY BE PREFERRED TO USE A TEMPORARY SOIL NAIL WALL FOR TEMPORARY SHORING FROM -Y2- STATION 99+58, 6.3' RT TO -Y2- STATION 100+08, 6.3' RT. FOR TEMPORARY SOIL NAIL WALLS, SEE TEMPORARY SOIL NAIL WALLS PROVISION.

Shoring Location No. 2:

FOR TEMPORARY SHORING AND POSITIVE PROTECTION FOR TEMPORARY SHORING, SEE PLANS AND TEMPORARY SHORING PROVISION.

TEMPORARY SHORING IS REQUIRED FOR THE STRUCTURE CONSTRUCTION FROM -Y2- STATION 99+58, 2.5' RT TO -Y2- STATION 100+08, 2.5' RT.

BEFORE BEGINNING TEMPORARY SHORING DESIGN OR CONSTRUCTION, SURVEY EXISTING GROUND ELEVATIONS IN THE VICINITY OF SHORING LOCATIONS TO DETERMINE ACTUAL SHORING HEIGHTS.

DESIGN TEMPORARY SHORING FROM -Y2- STATION 99+58, 2.5' RT TO -Y2- STATION 100+08, 2.5' RT, FOR THE FOLLOWING ASSUMED SOIL PARAMETERS AND GROUNDWATER ELEVATION:



- UNIT WEIGHT ( $\gamma$ ) = 120 LB/CF
- FRICTION ANGLE ( $\phi$ ) = 30 DEGREES
- COHESION (c) = 0 LB/SF
- GROUNDWATER ELEVATION = 2015 FT

DO NOT USE STANDARD TEMPORARY SHORING FOR TEMPORARY SHORING FROM -Y2- STATION 99+58, 2.5' RT TO -Y2- STATION 100+08, 2.5' RT. SEE TEMPORARY SHORING SPECIAL PROVISION.

AT THE CONTRACTOR'S OPTION, USE A STANDARD TEMPORARY WALL FOR TEMPORARY SHORING FROM -Y2- STATION 99+58, 2.5' RT TO -Y2- STATION 100+08, 2.5' RT. SEE GEOTECHNICAL STANDARD DETAIL 1801.02 FOR STANDARD TEMPORARY WALLS.

IF GROUNDWATER OR THE FLOOD ELEVATION IS ABOVE THE REINFORCED ZONE, DO NOT USE A STANDARD TEMPORARY WALL FOR TEMPORARY SHORING FROM -Y2- STATION 99+58, 2.5' RT TO -Y2- STATION 100+08, 2.5' RT. CONTRACTOR DESIGNED SHORING IS REQUIRED.

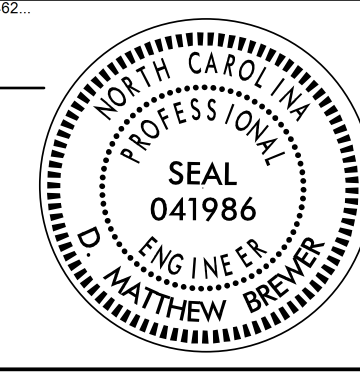
I:\22\2026\X\22\2026\A-0009\Traffic\TrafficContr\TCP\A-0009CD\A-0009CD-TC-TMP\_02\Temp Shoring Data.dgn  
User: jsmelvin

|  |   |   |  |
|--|---|---|--|
| APPROVED: <u>Matthew Brewer</u><br><small>386729CD\A\ACT1482...</small><br>DATE: 2/26/2026 |  |  | <h2 style="margin: 0;">TEMPORARY SHORING DATA</h2> |
| <b>DOCUMENT NOT CONSIDERED FINAL UNLESS ALL SIGNATURES COMPLETED</b>                       |   |   |  |

| <p><b>SIGN NUMBER:</b> DET-1<br/> <b>TYPE:</b> STATIONARY<br/> <b>QUANTITY:</b> SEE PLANS<br/> <b>SIGN WIDTH:</b> 3'-6"<br/> <b>HEIGHT:</b> 1'-6"<br/> <b>TOTAL AREA:</b> 5.3 Sq.Ft.<br/> <b>BORDER TYPE:</b> INSET<br/> <b>RECESS:</b> 0.38"<br/> <b>WIDTH:</b> 0.63"<br/> <b>RADII:</b> 1.5"<br/> <b>NO. Z BARS:</b><br/> <b>LENGTH:</b></p> | <p><b>BACKG COLOR:</b> Fluorescent Orange<br/> <b>COPY COLOR:</b> Black</p> <table border="1" style="width: 100%; border-collapse: collapse;"> <thead> <tr> <th>SYMBOL</th> <th>X</th> <th>Y</th> <th>WID</th> <th>HT</th> </tr> </thead> <tbody> <tr><td> </td><td> </td><td> </td><td> </td><td> </td></tr> <tr><td> </td><td> </td><td> </td><td> </td><td> </td></tr> <tr><td> </td><td> </td><td> </td><td> </td><td> </td></tr> <tr><td> </td><td> </td><td> </td><td> </td><td> </td></tr> <tr><td> </td><td> </td><td> </td><td> </td><td> </td></tr> <tr><td> </td><td> </td><td> </td><td> </td><td> </td></tr> <tr><td> </td><td> </td><td> </td><td> </td><td> </td></tr> <tr><td> </td><td> </td><td> </td><td> </td><td> </td></tr> <tr><td> </td><td> </td><td> </td><td> </td><td> </td></tr> </tbody> </table> <p><b>MAT'L:</b> 0.080" (2.0 mm) ALUMINUM</p> | SYMBOL | X   | Y  | WID | HT |  |  |  |  |  |  |  |  |  |  |  |  |  |  |  |  |  |  |  |  |  |  |  |  |  |  |  |  |  |  |  |  |  |  |  |  |  |  |  |  |  |  |  |  |  | <p><b>DESIGN BY:</b> SGM<br/> <b>PROJECT ID:</b> A-0009CD<br/> <b>CHECKED BY:</b> JLT<br/> <b>LOCATION:</b> GRAHAM CO<br/> <b>DATE:</b> Mar 31, 2022<br/> <b>DIV:</b> 14</p> <div style="text-align: center;"> </div> <p>BORDER<br/> R=1.5"<br/> TH=0.63"<br/> IN=0.38"</p> <p style="text-align: right;">Spacing Factor is 1 unless specified otherwise</p> |
|--|---|--------|-----|----|-----|----|--|--|--|--|--|--|--|--|--|--|--|--|--|--|--|--|--|--|--|--|--|--|--|--|--|--|--|--|--|--|--|--|--|--|--|--|--|--|--|--|--|--|--|--|--|--|
| SYMBOL   | X   | Y      | WID | HT |     |    |  |  |  |  |  |  |  |  |  |  |  |  |  |  |  |  |  |  |  |  |  |  |  |  |  |  |  |  |  |  |  |  |  |  |  |  |  |  |  |  |  |  |  |  |  |  |
|  |   |        |     |    |     |    |  |  |  |  |  |  |  |  |  |  |  |  |  |  |  |  |  |  |  |  |  |  |  |  |  |  |  |  |  |  |  |  |  |  |  |  |  |  |  |  |  |  |  |  |  |  |
|  |   |        |     |    |     |    |  |  |  |  |  |  |  |  |  |  |  |  |  |  |  |  |  |  |  |  |  |  |  |  |  |  |  |  |  |  |  |  |  |  |  |  |  |  |  |  |  |  |  |  |  |  |
|  |   |        |     |    |     |    |  |  |  |  |  |  |  |  |  |  |  |  |  |  |  |  |  |  |  |  |  |  |  |  |  |  |  |  |  |  |  |  |  |  |  |  |  |  |  |  |  |  |  |  |  |  |
|  |   |        |     |    |     |    |  |  |  |  |  |  |  |  |  |  |  |  |  |  |  |  |  |  |  |  |  |  |  |  |  |  |  |  |  |  |  |  |  |  |  |  |  |  |  |  |  |  |  |  |  |  |
|  |   |        |     |    |     |    |  |  |  |  |  |  |  |  |  |  |  |  |  |  |  |  |  |  |  |  |  |  |  |  |  |  |  |  |  |  |  |  |  |  |  |  |  |  |  |  |  |  |  |  |  |  |
|  |   |        |     |    |     |    |  |  |  |  |  |  |  |  |  |  |  |  |  |  |  |  |  |  |  |  |  |  |  |  |  |  |  |  |  |  |  |  |  |  |  |  |  |  |  |  |  |  |  |  |  |  |
|  |   |        |     |    |     |    |  |  |  |  |  |  |  |  |  |  |  |  |  |  |  |  |  |  |  |  |  |  |  |  |  |  |  |  |  |  |  |  |  |  |  |  |  |  |  |  |  |  |  |  |  |  |
|  |   |        |     |    |     |    |  |  |  |  |  |  |  |  |  |  |  |  |  |  |  |  |  |  |  |  |  |  |  |  |  |  |  |  |  |  |  |  |  |  |  |  |  |  |  |  |  |  |  |  |  |  |
|  |   |        |     |    |     |    |  |  |  |  |  |  |  |  |  |  |  |  |  |  |  |  |  |  |  |  |  |  |  |  |  |  |  |  |  |  |  |  |  |  |  |  |  |  |  |  |  |  |  |  |  |  |

**LETTER POSITIONS**

| Letter spacings are to start of next letter |     |     |     |     |     |     |     |     |   |     |     |     | Series/Size |  |  |  |  |  |  |  |        |      |
|---|-----|-----|-----|-----|-----|-----|-----|-----|---|-----|-----|-----|-------------|--|--|--|--|--|--|--|--------|------|
|   |     |     |     |     |     |     |     |     |   |     |     |     | Text Length |  |  |  |  |  |  |  |        |      |
|   | S   | T   | E   | C   | O   | A   | H   |     | R | D   |     |     |             |  |  |  |  |  |  |  | C 2000 |      |
|   | 3.4 | 3.3 | 3.3 | 3.3 | 3.7 | 3.6 | 3.9 | 2.8 | 5 | 3.6 | 2.8 | 3.4 |             |  |  |  |  |  |  |  |        | 35.2 |
|   |     |     |     |     |     |     |     |     |   |     |     |     |             |  |  |  |  |  |  |  |        |      |
|   |     |     |     |     |     |     |     |     |   |     |     |     |             |  |  |  |  |  |  |  |        |      |
|   |     |     |     |     |     |     |     |     |   |     |     |     |             |  |  |  |  |  |  |  |        |      |
|   |     |     |     |     |     |     |     |     |   |     |     |     |             |  |  |  |  |  |  |  |        |      |
|   |     |     |     |     |     |     |     |     |   |     |     |     |             |  |  |  |  |  |  |  |        |      |
|   |     |     |     |     |     |     |     |     |   |     |     |     |             |  |  |  |  |  |  |  |        |      |

FILENAME: A-0009CC\_TC\_TMP\_02X(Special Sign)

NORTH CAROLINA D.O.T. SIGN DETAIL

I:\22\2026  
 X:\CIC\A-0009\Traffic\TrafficControl\TCP\A-0009CD\A-0009CD\_TC\_TMP\_02B(Special Sign).dgn  
 User: jsmelvin

|  |  |  |                                   |
|--|--|--|-----------------------------------|
| <p>APPROVED: <i>Jimmy Terry</i><br/> <small>FD39F3882E94D0...</small><br/>                 DATE: 2/27/2026</p> |  |  | <p><b>SPECIAL SIGN DESIGN</b></p> |
| <p><b>DOCUMENT NOT CONSIDERED FINAL UNLESS ALL SIGNATURES COMPLETED</b></p>                                    |  |  |                                   |

**CONTINUOUS LINES**

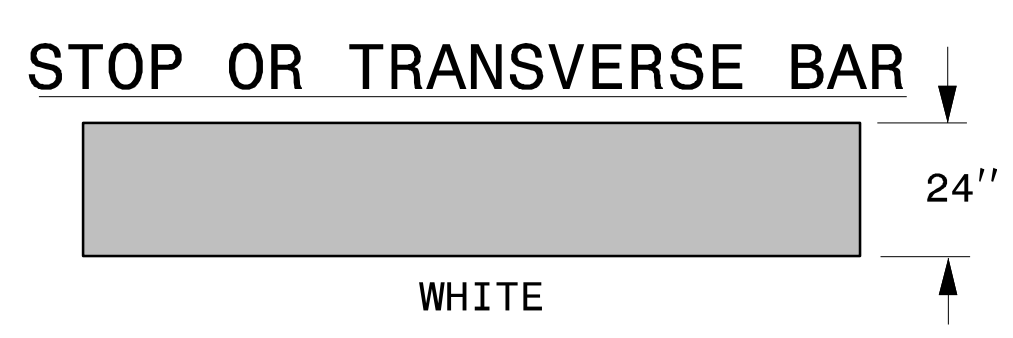
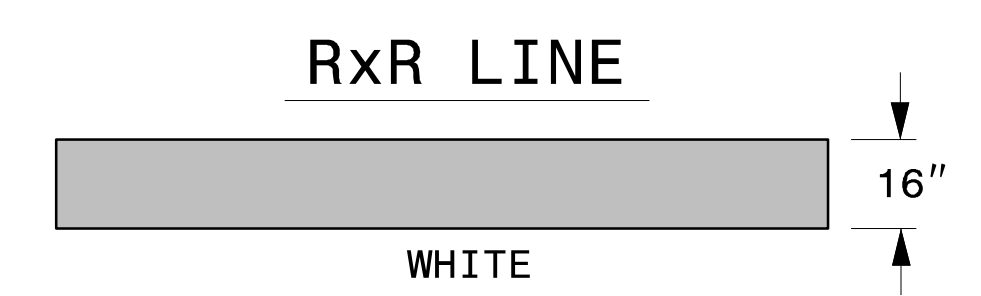
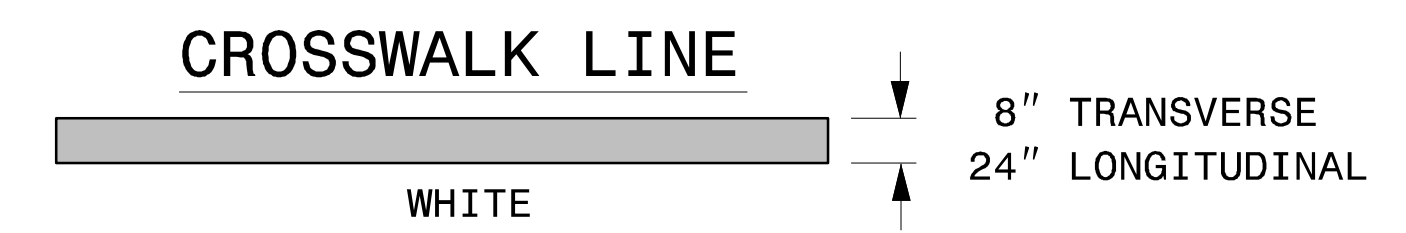
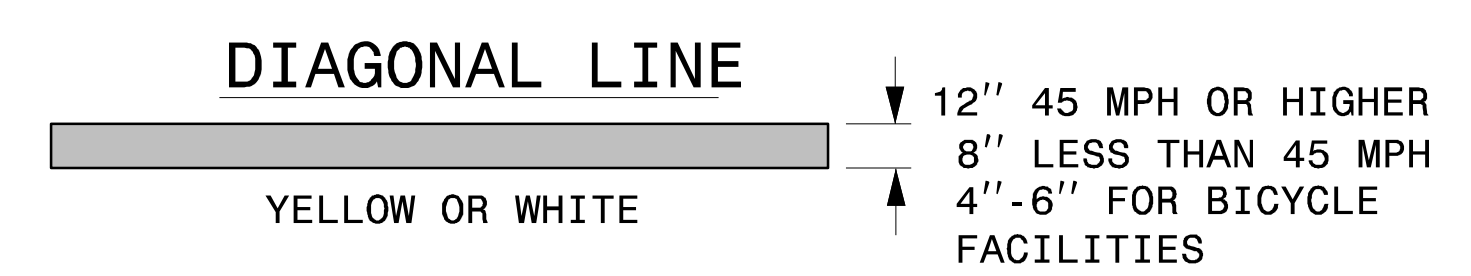
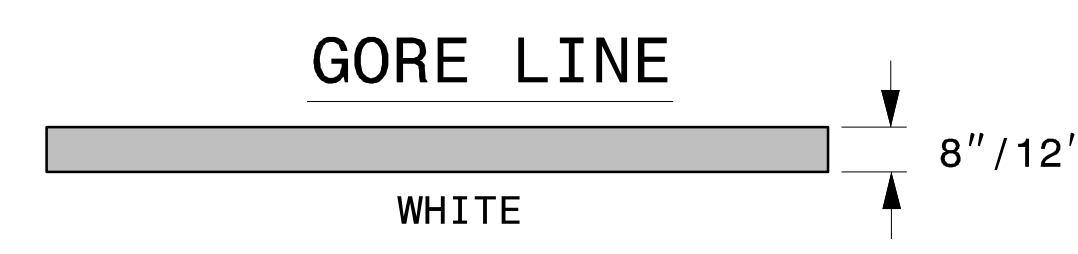
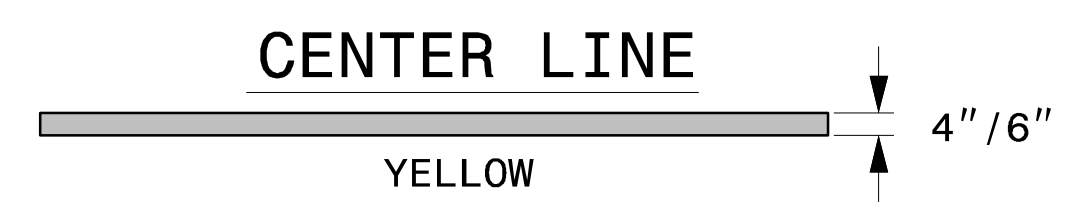
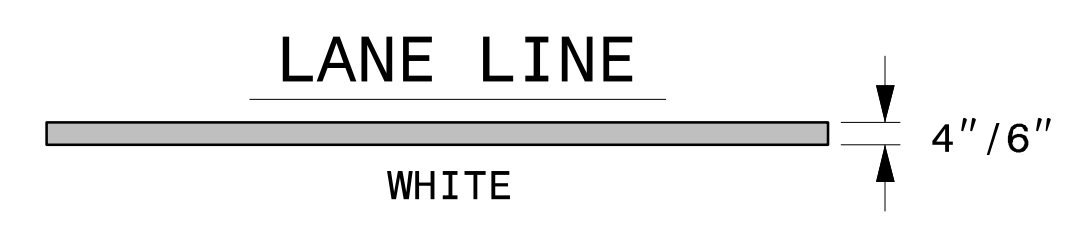
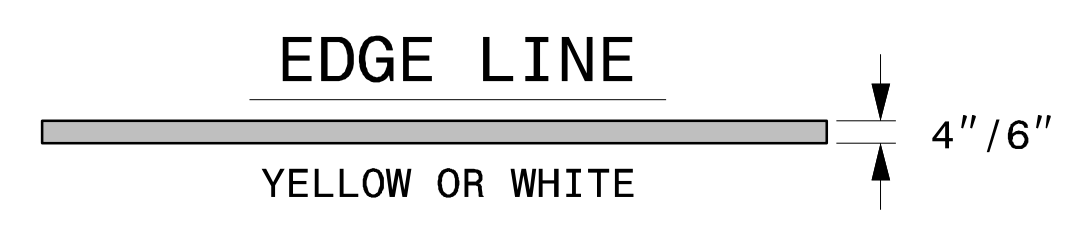

**10'-30'/SP SKIP LINE**

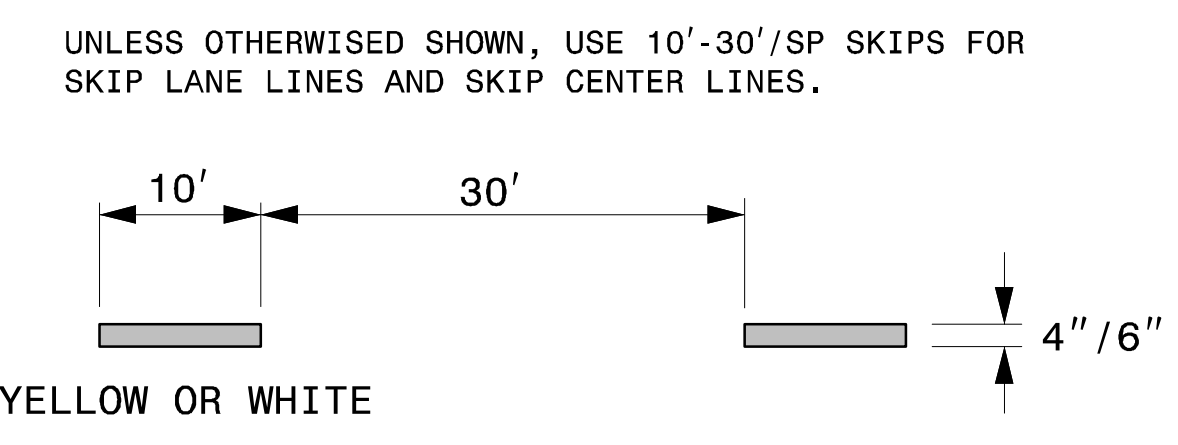

**2'-6'/SP MINI-SKIP LINE**

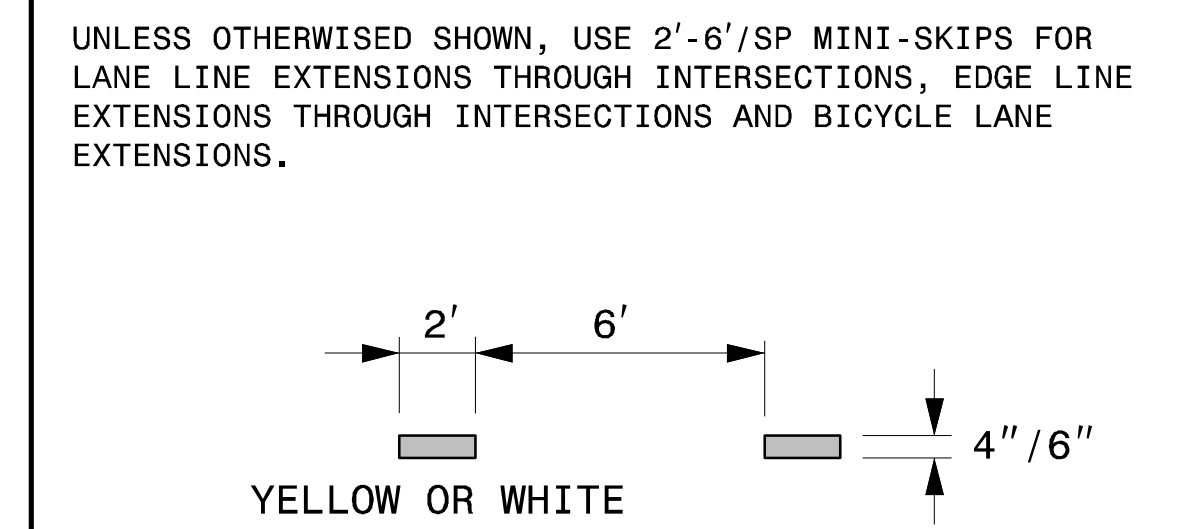

**3'-3'/SP MINI-SKIP LINE**

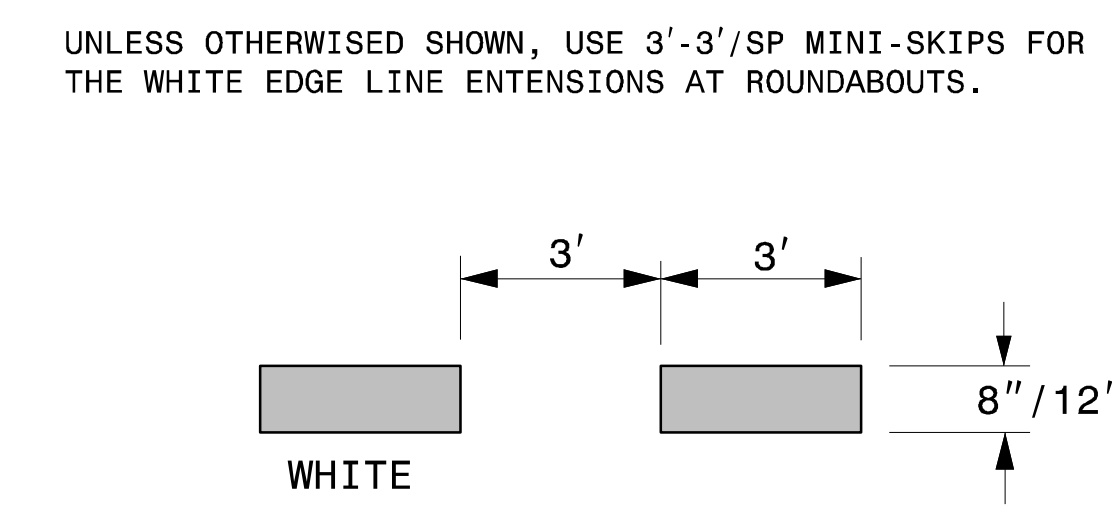

**3'-9'/SP MINI-SKIP LINE**

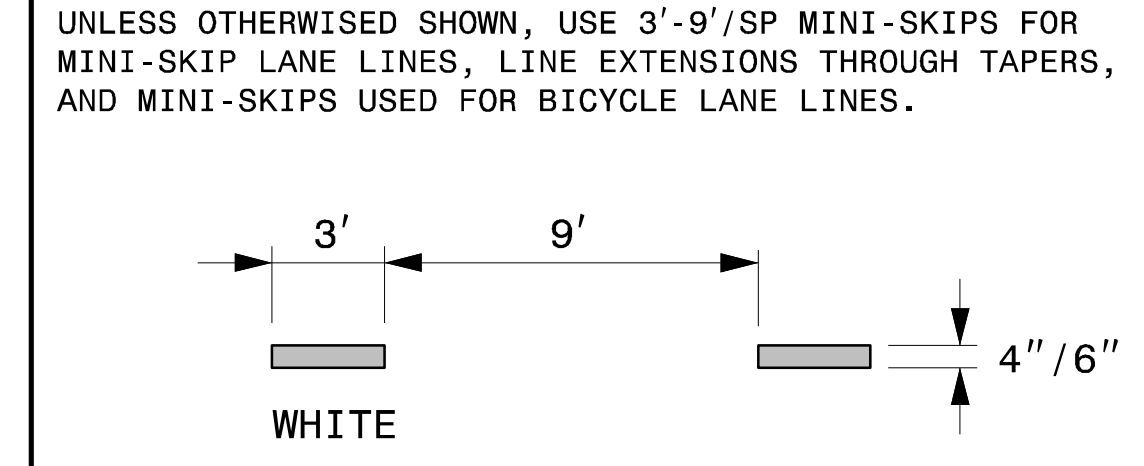

- GENERAL NOTES:
- 1- USE 6" LANE, EDGE, AND CENTER LINES ON ALL FULL CONTROL OF ACCESS FACILITIES AND OTHER ROUTES AS DIRECTED BY THE ENGINEER.
  - 2- LANE LINES INDICATED AS "WIDE" ON THE ROADWAY STANDARD DRAWINGS SHALL BE AT LEAST TWICE THE WIDTH OF THE NORMAL LINE.
  - 3- GORE LINES SHALL BE TWICE THE WIDTH OF THE NORMAL LINE.

STATE OF NORTH CAROLINA  
DEPT. OF TRANSPORTATION  
DIVISION OF HIGHWAYS  
RALEIGH, N.C.

ROADWAY DETAIL DRAWING FOR  
**PAVEMENT MARKINGS**  
LINE TYPES AND OFFSETS

SHEET 1 OF 2  
**1205D01**

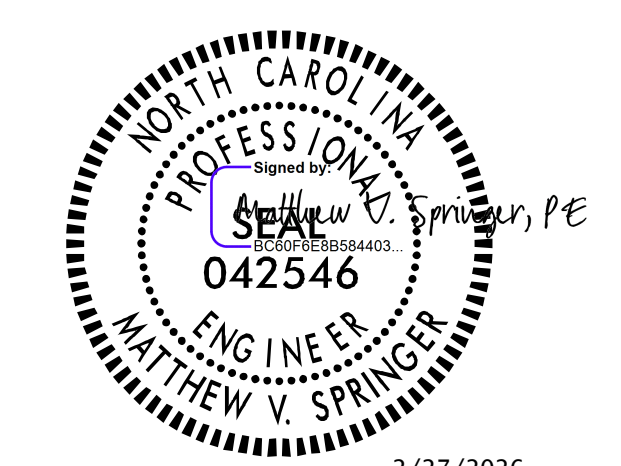

2/27/2026

**CONTRACTS STANDARDS AND DEVELOPMENT UNIT**  
Office 919-707-8950 FAX 919-250-4119

**SEE TITLE BLOCK**

ORIGINAL BY: M.V. SPRINGER DATE: 2-15-24  
MODIFIED BY: \_\_\_\_\_ DATE: \_\_\_\_\_  
CHECKED BY: \_\_\_\_\_ DATE: \_\_\_\_\_  
FILE SPEC.: \_\_\_\_\_

# PHASING

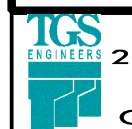
|   |           |
|---|-----------|
| PROJ. REFERENCE NO.   | SHEET NO. |
| A-0009CD  | TMP-3     |
|  TGS ENGINEERS<br>201 W. MARRION ST. STE 200<br>SHELBY, NC 28150<br>PH (704) 476-0003<br>CORP. LICENSE NO.: C-0275 |           |

### NOTES:

- UNLESS OTHERWISE NOTED PROVIDE ACCESS TO ALL DRIVES AND SIDE STREETS AT ALL TIMES.
- UNLESS OTHERWISE NOTED MAINTAIN THE EXISTING TRAFFIC PATTERN OF NC 28 AND ALL APPLICABLE STREETS IN THE PROJECT AREA AT ALL TIMES WHILE FLAGGERS ARE NOT AT WORK.
- UNLESS OTHERWISE NOTED USE NCDOT RSD 1101.02, SHEET 1 OF 19 FOR TEMPORARY LANE CLOSURES.
- WHEN WEDGING OVER EXISTING PAVEMENT, WEDGE TO PROPOSED ELEVATION LESS THE FINAL LAYER OF SURFACE COURSE, OR WEDGE AS NEEDED TO MAINTAIN TRAFFIC AS DIRECTED BY THE ENGINEER.

## NC 28 CONSTRUCTION

### PHASE I

(TMP-4 THRU TMP-7)

#### STEP 1

INSTALL ADVANCED WORK ZONE WARNING SIGNS ON ALL ALIGNMENTS IN ACCORDANCE WITH NCDOT RSD 1101.01, SHEET 3 OF 3.

#### STEP 2

UNLESS OTHERWISE NOTED MAINTAIN THE EXISTING NC 28 TRAFFIC PATTERN. USING TEMPORARY LANE AND SHOULDER CLOSURES IN ACCORDANCE WITH NCDOT RSD 1101.02, SHEET 1 OF 19, AND RSD 1101.04 AND FLAGGERS AS NEEDED CONSTRUCT THE FOLLOWING UP TO BUT NOT INCLUDING THE FINAL LAYER OF SURFACE COURSE:

NOTE: PRIOR TO START OF LEFT SIDE WIDENING, USE ADA COMPLIANT PEDESTRIAN BARRICADES TO CLOSE EXISTING MUP ON THE LEFT SIDE OF NC 28, REMOVE RFB AND CROSSWALKS.

WIDEN NC 28 FROM -Y2- STA 89+80± TO STA 139+00±, LT  
WEDGE EXISTING NC 28 PAVEMENT FROM -Y2- STA 89+80± TO 90+73±  
WIDEN NC 28 FROM -Y2- STA 134+05± TO STA 166+45±, RT  
WIDEN NC 28 FROM -Y2- STA 155+53± TO STA 166+45±, LT

WEDGE AND WIDEN SIDE STREETS UP TO BUT NOT INCLUDING THE FINAL LAYER OF SURFACE COURSE AS SHOWN ON PLANS:  
SR 1236 LOWER STECOAH RD (TMP-4)

PERFORM ROCK BLASTING (SEE RSD 1101.06, AND INTERMEDIATE CONTRACT TIME).

CONSTRUCT RETAINING WALL #41 FROM -Y2- STA 146+60± TO 148+80±, RT (TMP-6)

PLACE DOUBLE FACED CONCRETE BARRIER TYPE T-2 AS FOLLOW:  
-Y2- STA 133+60± TO 137+25±, RT (TMP-5)  
-Y2- STA 153+25± TO 158+12±, RT (TMP-6)  
-Y2- STA 156+50± TO 161+00±, LT (TMP-6)

#### STEP 3 (TMP-7)

USE FLAGGERS TO WIDEN NC 28 FROM -Y2- STA. 89+90± TO -Y2- STA 99+26± UP TO BUT NOT INCLUDING FINAL LAYER OF SURFACE COURSE. (SEE TMP-7, DETAIL "A").

USE FLAGGERS TO CONSTRUCT NEW ALIGNMENT OF BILL CRISP RD FROM -Y3- STA 10+50± TO -Y3- STA 14+02± UP TO BUT NOT INCLUDING FINAL LAYER OF SURFACE COURSE (SEE TMP-7, DETAIL "A").

USE FLAGGERS TO CONSTRUCT TEMPORAY PAVEMENT FROM -Y2- STA 97+60± TO -Y2- STA 102+15± (RIGHT) AND INSTALL TEMPORARY GUARDRAIL. ADD ADDITIONAL LEFT SIDE TEMPORARY PAVEMENT FROM -Y2- STA. 101+30± TO -Y2- STA 101+80± (RIGHT) TO ACCOMODATE 16:1 PCB FLARE (SEE TMP-7, DETAIL "A")

PLACE TEMPORAY PAINT MARKINGS AND OPEN NEW ALIGNMENT OF BILL CRISP RD WITH TRAFFIC SHIFT ON NC-28 (SEE TMP-7, DETAIL "B").

#### STEP 4 (TMP-7)

USE FLAGGERS AND INSTALL ANCHORED PCB.THEN, BEHIND PCB, INSTALL TEMPORARY SHORING NO.1, AND CONSTRUCT STAGE 1 OF 12' X 5' RCBC AT -Y2- STA 99+82± (SEE TMP-7, DETAIL "B").

#### STEP 5 (TMP-7)

USING FLAGGERS, CONTINUE WIDENING OF NC 28 (SEE STEP 1) AND CONSTRUCT TEMPORARY PAVEMENT FROM -Y2- STA 98+97± TO -Y2- STA 102+75± (LEFT) AND INSTALL TEMPORARY GUARDRAIL. REMOVE AND RESET PCB AS NECESSARY.

#### STEP 6

INSTALL AND COVER OFFSITE DETOUR SIGNING FOR STECOAH RD. AND SHIFT WARNING SIGNS FOR UPCOMING PHASE II SHIFT ON NC 28 (SEE TMP-9 AND 10).

### PHASE II

NOTE: COMPLETE THE WORK OF PHASE II, STEP 1A IN 120 CONSECUTIVE CALENDER DAYS.  
SEE INTERMEDIATE CONTRACT AND LIQUIDATED DAMAGES.

#### STEP 1A (TMP-8 THRU TMP-10)

UNCOVER SHIFT WARNING SIGNS, PLACE TEMPORARY PAINT PAVEMENT MARKINGS AND USE FLAGGERS TO SHIFT NC 28 TRAFFIC AS SHOWN ON TMP-9.

UNCOVER DETOUR SIGNING, CLOSE AND DETOUR STECOAH RD. (SEE TMP-10)

USING FLAGGERS, INSTALL ANCHORED PCB. THEN, BEHIND PCB, INSTALL TEMPORARY SHORING NO.2 AND CONSTRUCT STAGE 2 OF 12' X 5' RCBC AT -Y2- STA 99+82±.

AWAY FROM TRAFFIC, CONSTRUCT PROPOSED 2-6'X6' RCBC UNDER STECOAH RD.

WIDEN NC 28 FROM -Y2- STA 99+50± TO 100+15± UP TO BUT NOT INCLUDING THE FINAL LAYER OF SURFACE COURSE.

INSTALL CURB AND GUTTER, GUARDRAIL, AND WEDGE EXISTING NC 28 FROM -Y2- STA 90+73± TO 101+00±, INCLUDING STECOAH RD UP TO BUT NOT INCLUDING THE FINAL LAYER OF SURFACE COURSE. REMOVE EXISTING PAVEMENT, INCLUDING TEMPORARY PAVEMENT INSTALLED IN PHASE I, STEP 2 (RIGHT).

USING FLAGGERS, REMOVE ANCHORED PCB.

REMOVE AND REPLACE TEMPORARY PAINT MARKINGS AND SHIFT NC 28 TO PHASE II, STEP 1B TRAFFIC PATTERN. COVER OR REMOVE DETOUR SIGNING AND RE-OPEN STECOAH RD.

#### STEP 1B (TMP-9)

USING FLAGGERS, REMOVE TEMPORARY PAVEMENT AND GUARDRAIL INSTALLED IN PHASE I, STEP 4 (LEFT).

CONSTRUCT DRIVEWAY AT -Y2- STA 100+00±.

CONSTRUCT CURB AND GUTTER FROM -Y2- STA 99+84± TO 104+06± (LEFT).

#### STEP 2 (TMP-11 THRU TMP-14)

USING TEMPORARY LANE CLOSURES, FLAGGERS, TRAFFIC SHIFT, AND UTILIZING THE NEWLY CONSTRUCTED PAVED SHOULDER IF NEEDED WEDGE EXISTING NC 28 PAVEMENT UP TO BUT NOT INCLUDING THE FINAL LAYER OF SURFACE COURSE AS FOLLOWS:

FROM -Y2- STA 101+00± TO -Y2- STA 166+45± (TMP-11 THRU TMP-14)

AT THE END OF EACH WORK DAY AND/OR WHEN FLAGGERS ARE NOT AT WORK, PLACE THE EXISTING NC 28 TRAFFIC IN A 2-LN 2 WAY PATTERN (11' MIN. LANE WIDTH).

PLACE PAVED SHOULDER AS FOLLOWS:  
-Y2- STA 139+00± TO 154+44±, LT (TMP-13).

WHILE MAINTAINING ACCESS CONSTRUCT SIDE STREETS UP TO BUT NOT INCLUDING THE FINAL LAYER OF SURFACE COURSE AS SHOWN ON PLANS:

SR 1230 HYDE TOWN RD (TMP-12)  
SR 1235 GUNTER GAP RD (TMP-13)

CONSTRUCT MULTI-USE PATH FROM -Y2- STA 98+96± TO STA 132+26± , RT (TMP-11 AND TMP-12).  
USE ADA COMPLIANT BARRICADES TO KEEP PATH CLOSED TO PEDESTRIAN/BIKE TRAFFIC UNTIL COMPLETION OF PROJECT. (SEE SPECIAL PROVISIONS).

### PHASE III

#### STEP 1 (TMP-15 & TMP-16)

USING TEMPORARY LANE CLOSURES AND FLAGGERS IN ACCORDANCE WITH NCDOT RSD 1101.02 SHEETS 1 AND 3 OF 19 MILL EXISTING PAVEMENT FROM -Y2- STA 166+45± TO 169+90±.

USING TEMPORARY LANE CLOSURES AND FLAGGERS IN ACCORDANCE WITH NCDOT RSD 1101.02 SHEETS 1 AND 3 OF 19 PLACE FINAL LAYER OF SURFACE COURSE AS FOLLOW:  
NC 28 FROM -Y2- 89+80± TO 169+90±.

AFTER FINAL LAYER OF SURFACE COURSE HAS BEEN PLACED CONSTRUCT MONOLITHIC CONCRETE ISLAND FORM -Y2- STA 159+52± TO 166+45±.

USING TEMPORARY LANE CLOSURES AND FLAGGERS IN ACCORDANCE WITH NCDOT RSD 1101.02 SHEETS 1 AND 3 OF 19 PLACE FINAL LAYER OF SURFACE COURSE ON SIDE STREETS.



-Y3A- SR 1291 STECOAH RD (TMP-15)  
SR 1236 LOWER STECOAH LN (TMP-18)  
SR 1230 HYDE TOWN RD (TMP-16)  
SR 1235 GUNTER GAP RD (TMP-16)

#### STEP 2

USING TEMPORARY LANE CLOSURES AND FLAGGERS IN ACCORDANCE WITH NCDOT RSD 1101.02 SHEETS 1 AND 3 OF 19 PLACE FINAL PAVEMENT MARKINGS AS SHOWN IN PAVEMENT MARKING PLANS.

REMOVE ALL TRAFFIC CONTROL DEVICES AND OPEN ALL ROADS TO TRAFFIC.

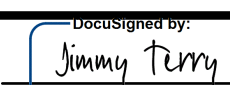
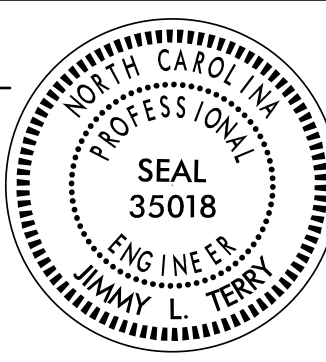
2/20/2026 10:58:11 AM \\na-0009\Traffic\TrafficControl\TCP\A-0009CD-A-0009CD-TC-TMP\_03(Phasing).dgn User: jsmelvin

|   |   |         |
|---|---|---------|
| APPROVED: <br>DATE: 2/27/2026<br>SEAL<br> |  | PHASING |
| DOCUMENT NOT CONSIDERED FINAL<br>UNLESS ALL SIGNATURES COMPLETED  |   |         |

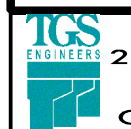
|   |           |
|---|-----------|
| PROJ. REFERENCE NO.   | SHEET NO. |
| A-0009CD  | TMP-4     |
|  <b>TGS ENGINEERS</b><br>201 W. MARION ST. STE 200<br>SHELBY, NC 28150<br>PH (704) 476-0003<br>CORP. LICENSE NO.: C-0275 |           |

SEE DETAIL SHEET TMP-7

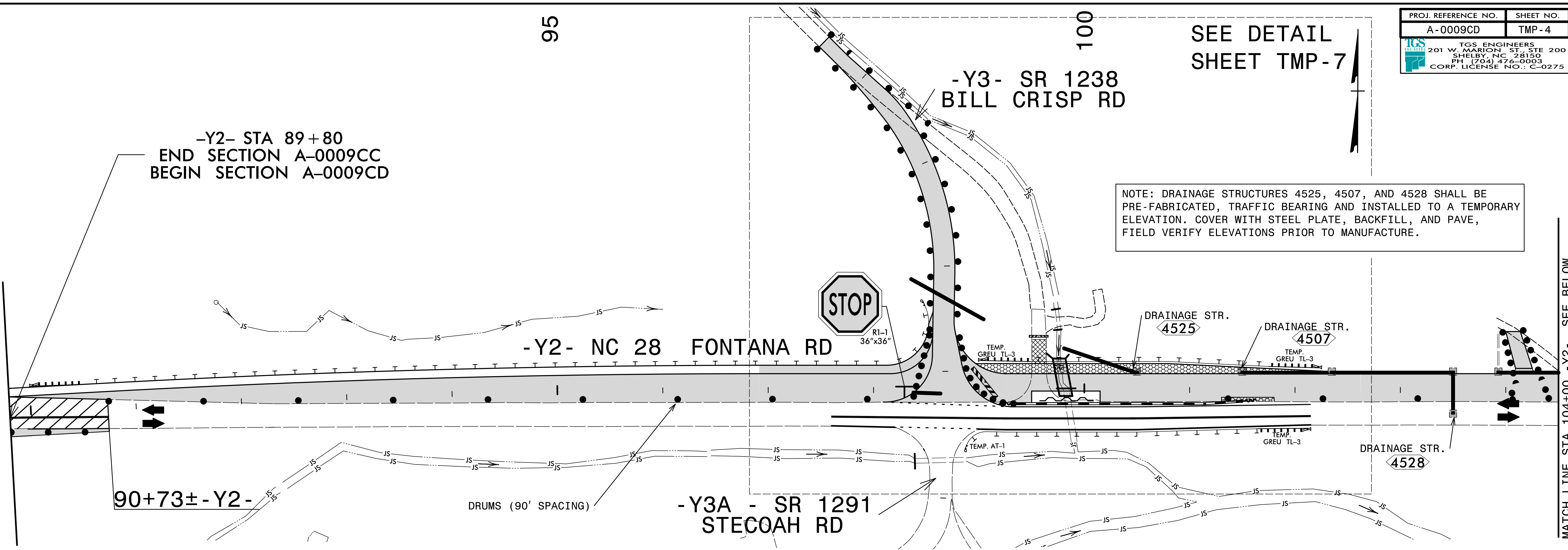

MATCH LINE STA 104+00 -Y2-, SEE BELOW

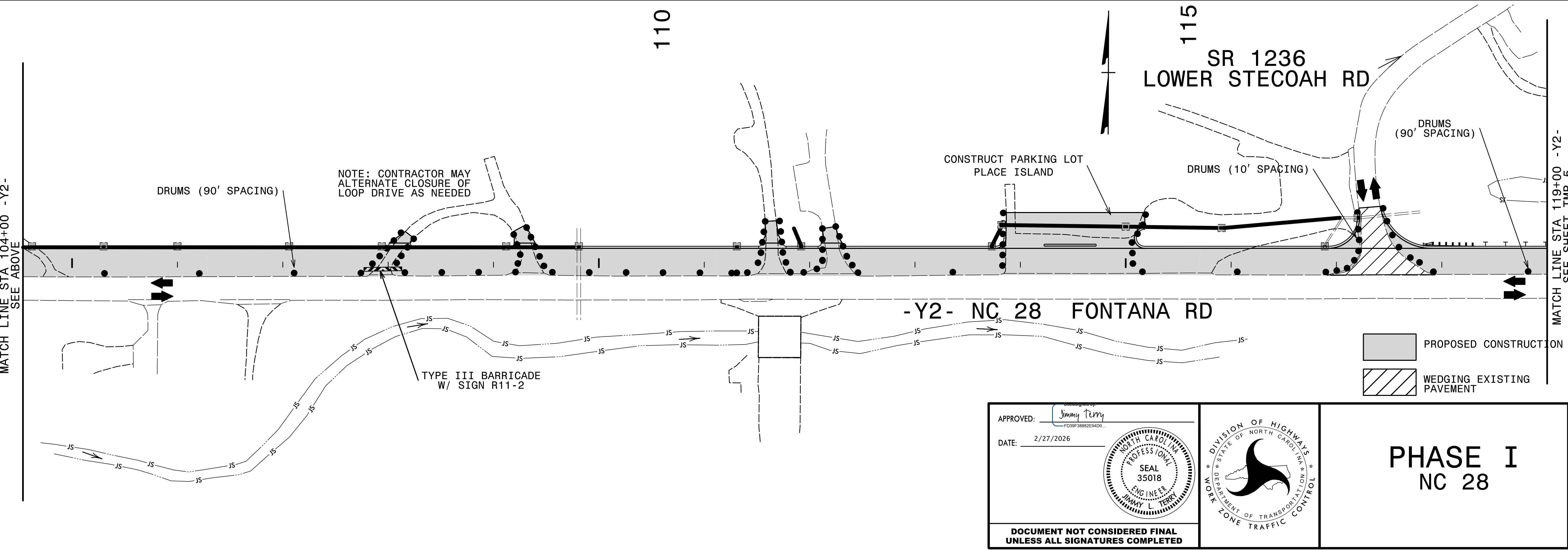

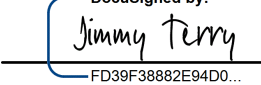
APPROVED:   
DATE: 2/27/2026

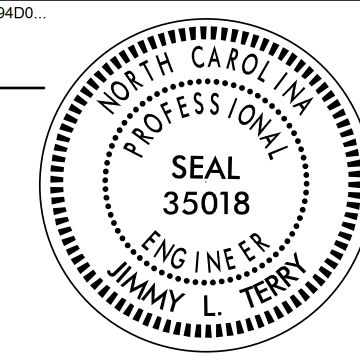

**DOCUMENT NOT CONSIDERED FINAL  
UNLESS ALL SIGNATURES COMPLETED**

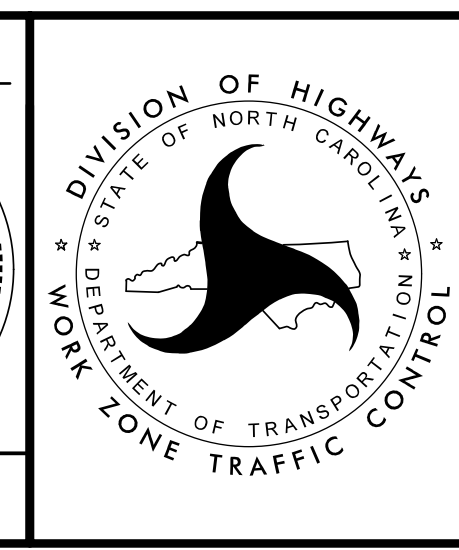

**PHASE I  
NC 28**

1/22/2026  
X:\NC\A-0009\Traffic\TrafficControl\TCP\A-0009CD\A-0009CD-TC\_TMP\_04(PHL)SL.dgn  
User: jsmelvin

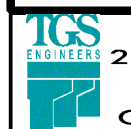
|   |           |
|---|-----------|
| PROJ. REFERENCE NO.   | SHEET NO. |
| A-0009CD  | TMP-5     |
|  <b>TGS ENGINEERS</b><br>201 W. MARION ST. STE 200<br>SHELBY, NC 28150<br>PH (704) 476-0003<br>CORP. LICENSE NO.: C-0275 |           |

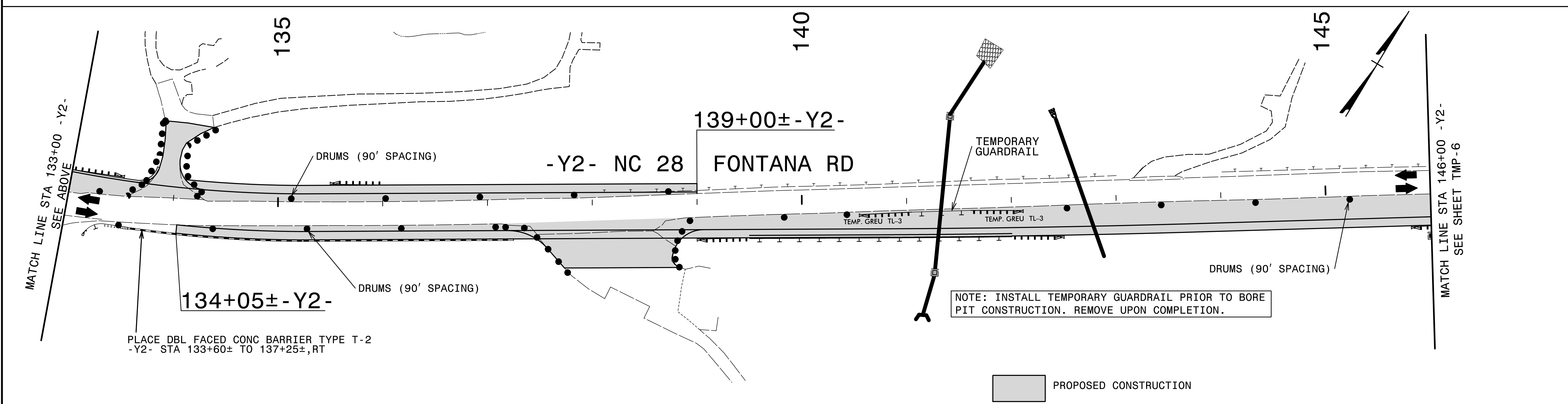
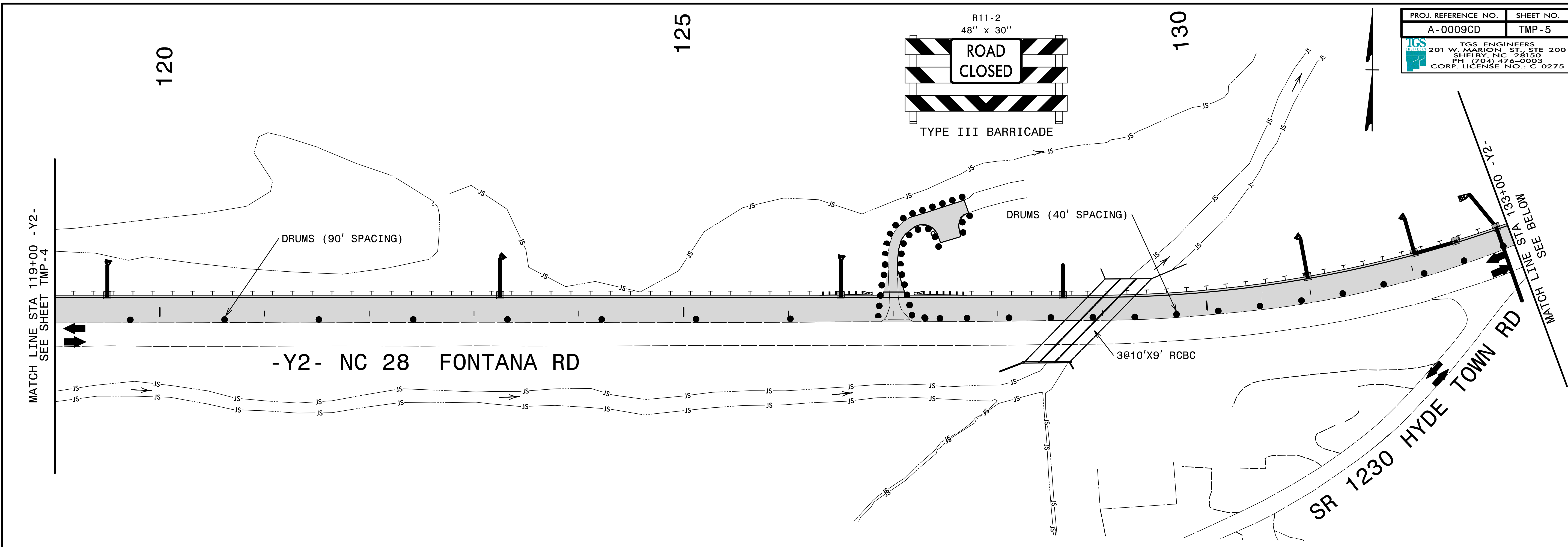

 PROPOSED CONSTRUCTION

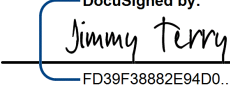
APPROVED:   
 DATE: 2/27/2026



**DOCUMENT NOT CONSIDERED FINAL  
UNLESS ALL SIGNATURES COMPLETED**

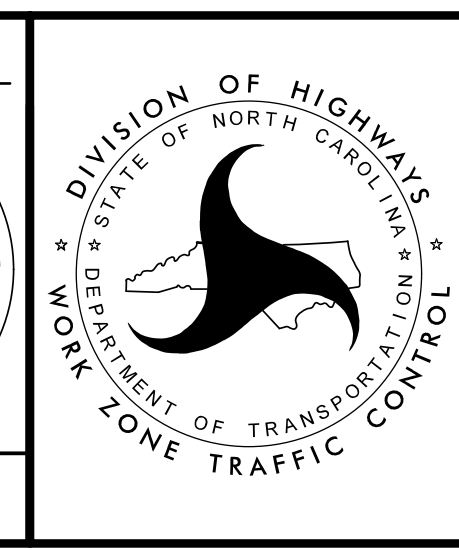

**PHASE I**  
**NC 28**

1/22/2026  
 V:\2026\A-0009\Traffic\TrafficControl\TCP\A-0009CD\A-0009CD-TC\_TMP\_05(PHL)S1.dgn  
 User: jsmelvin

|   |           |
|---|-----------|
| PROJ. REFERENCE NO.   | SHEET NO. |
| A-0009CD  | TMP-6     |
|  <b>TGS ENGINEERS</b><br>201 W. MARION ST. STE 200<br>SHELBY, NC 28150<br>PH (704) 476-0003<br>CORP. LICENSE NO.: C-0275 |           |

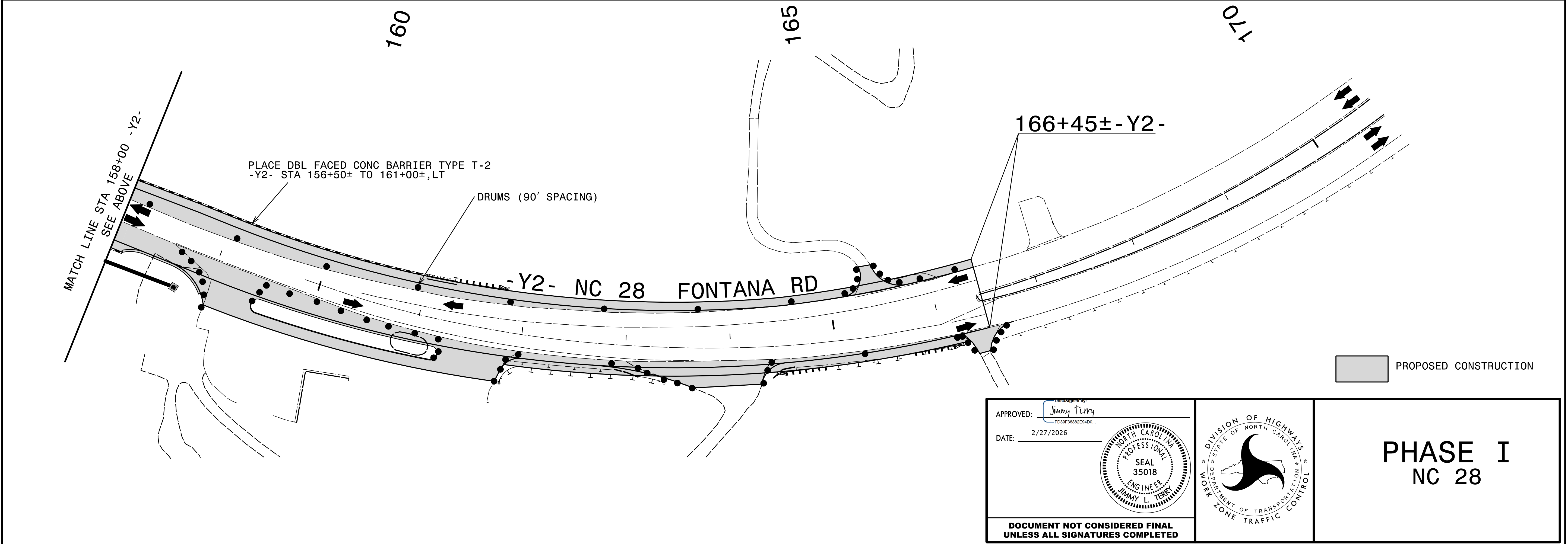
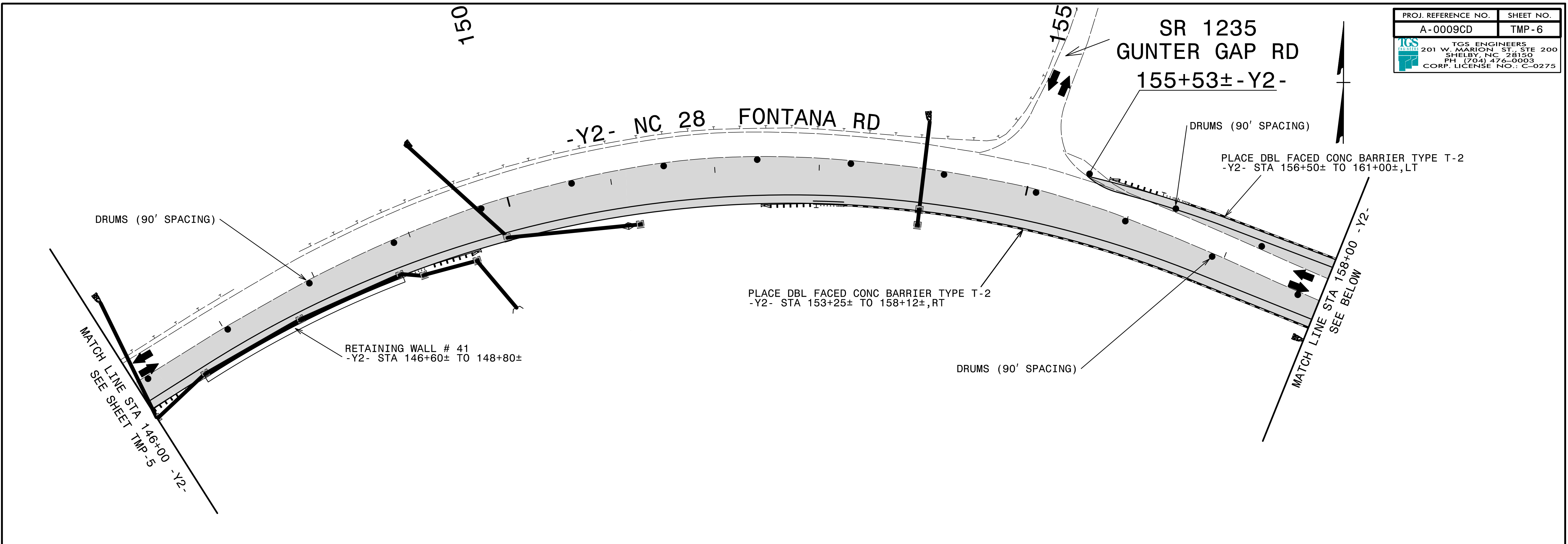

1/22/2026  
 X:\CADD\A-0009\Traffic\TrafficContr\TCP\A-0009CD-A-0009CD-TC-TMP\_06(PHL-SI).dgn  
 User: jsmelvin

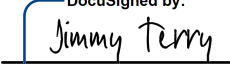
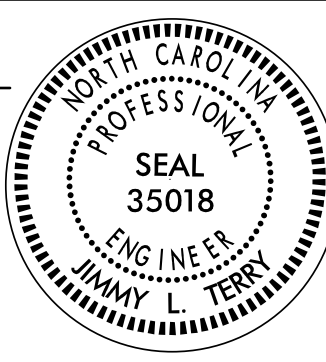
APPROVED:   
 DATE: 2/27/2026  

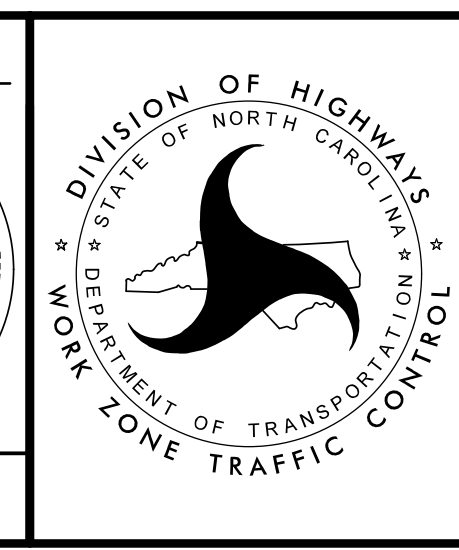

**PHASE I**  
**NC 28**

**DOCUMENT NOT CONSIDERED FINAL  
UNLESS ALL SIGNATURES COMPLETED**

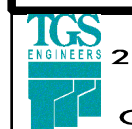
|   |           |
|---|-----------|
| PROJ. REFERENCE NO.   | SHEET NO. |
| A-0009CD  | TMP-7     |
|  <b>TGS ENGINEERS</b><br>201 W. MARION ST. STE 200<br>SHELBY, NC 28150<br>PH (704) 476-0003<br>CORP. LICENSE NO.: C-0275 |           |

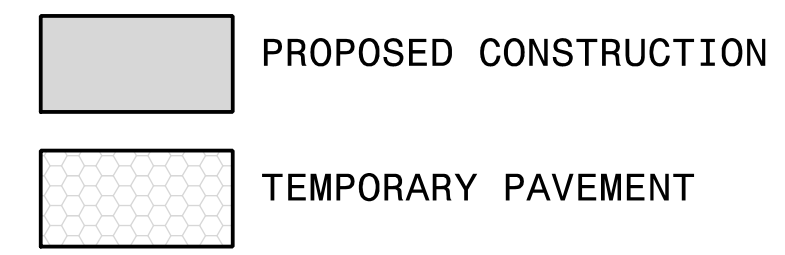

### PHASE I, STEP 3 DETAIL "A"

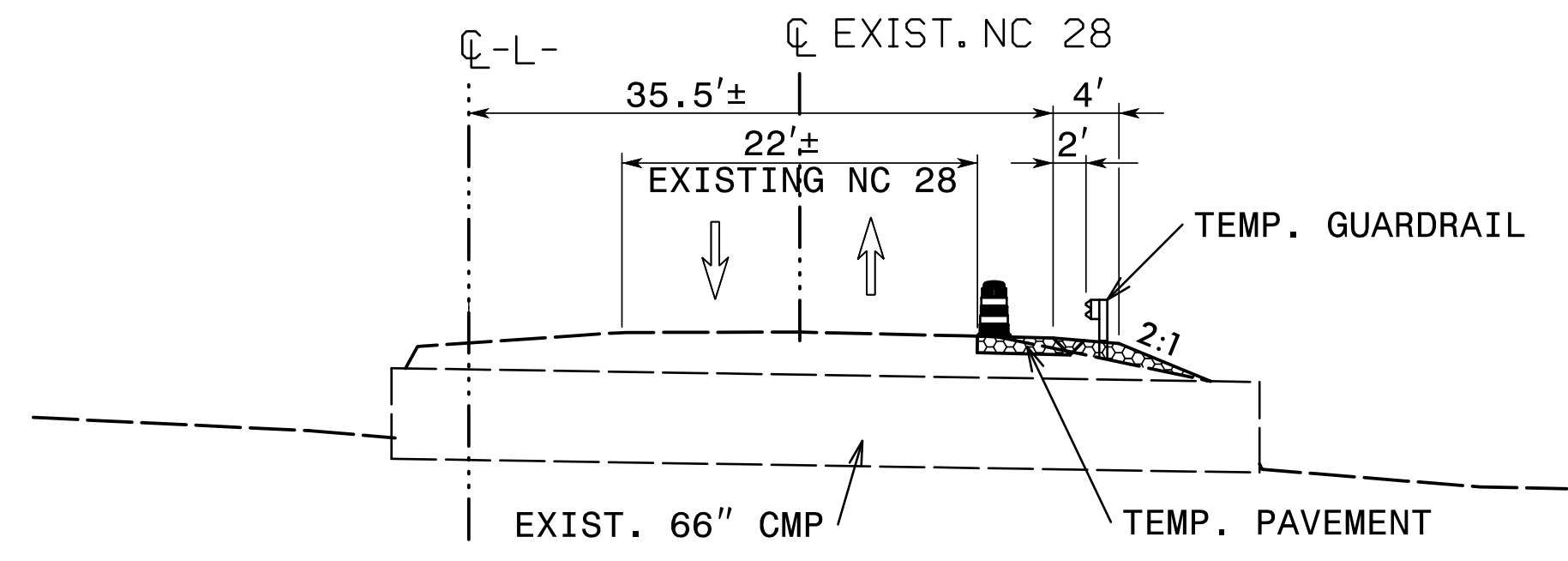
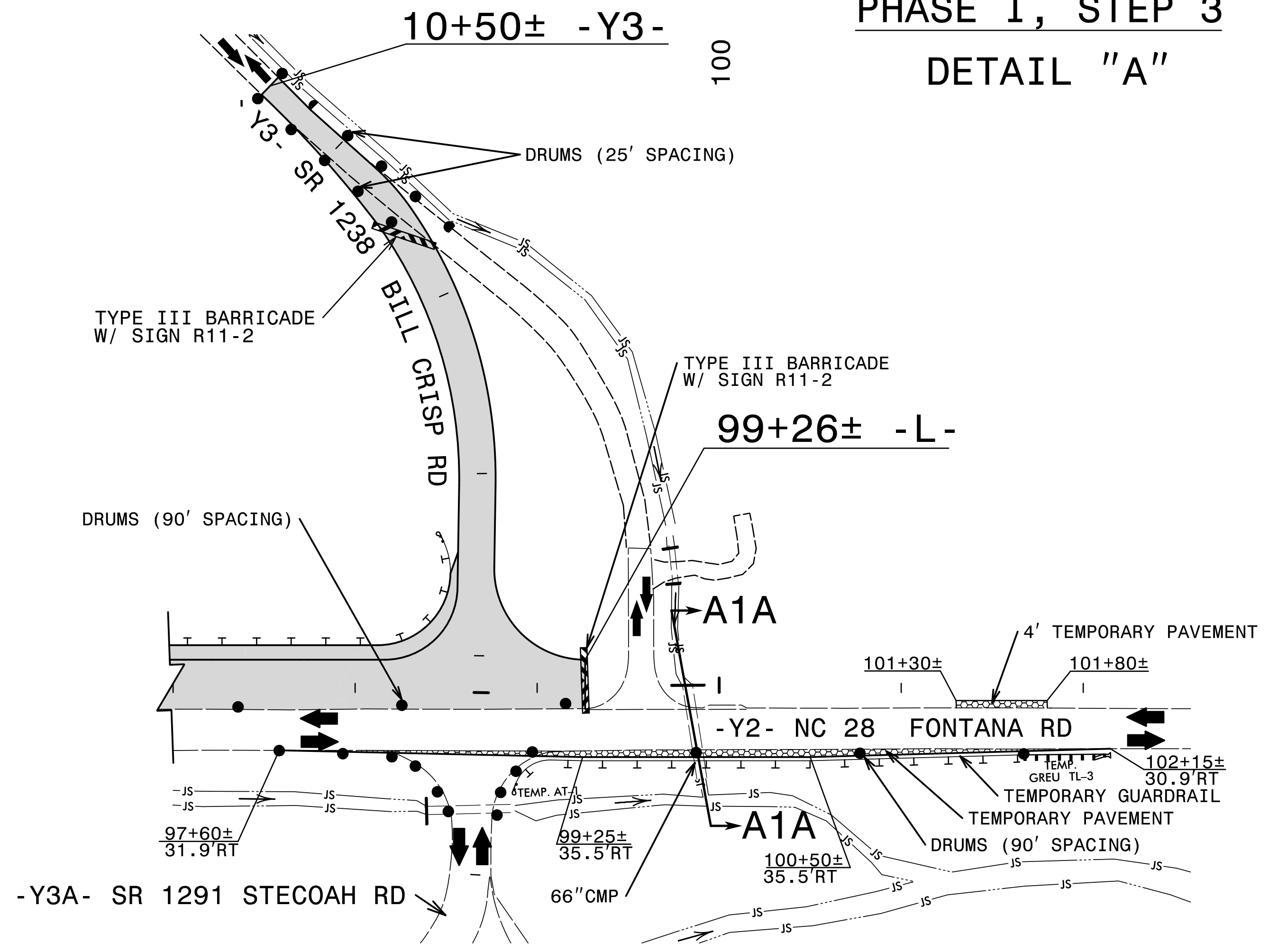

**SECTION A1A-A1A  
-Y2- STA 99+82±**

### PHASE I, STEPS 4 AND 5 DETAIL "B"

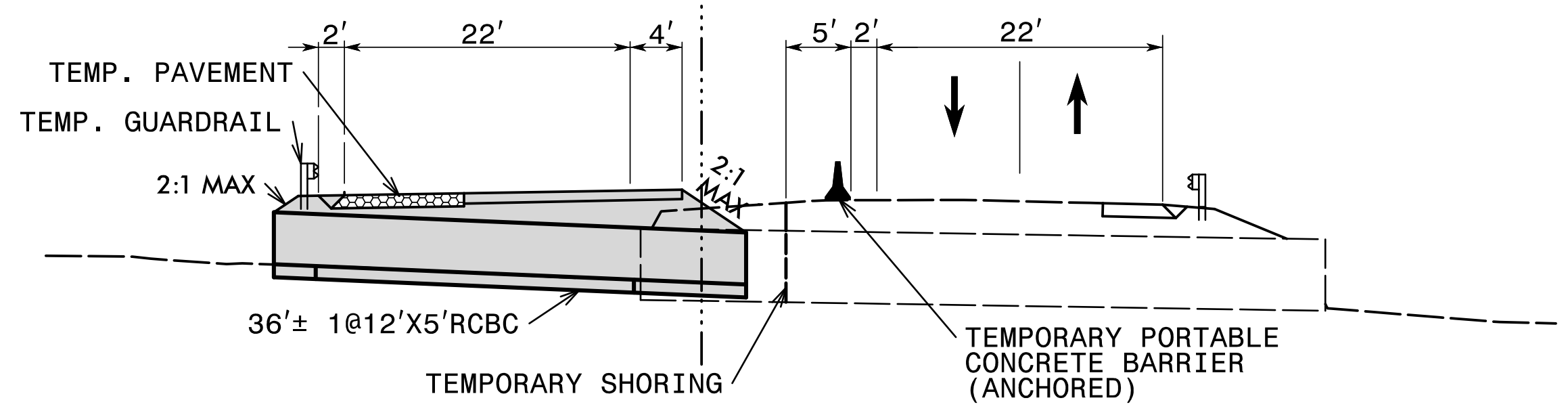
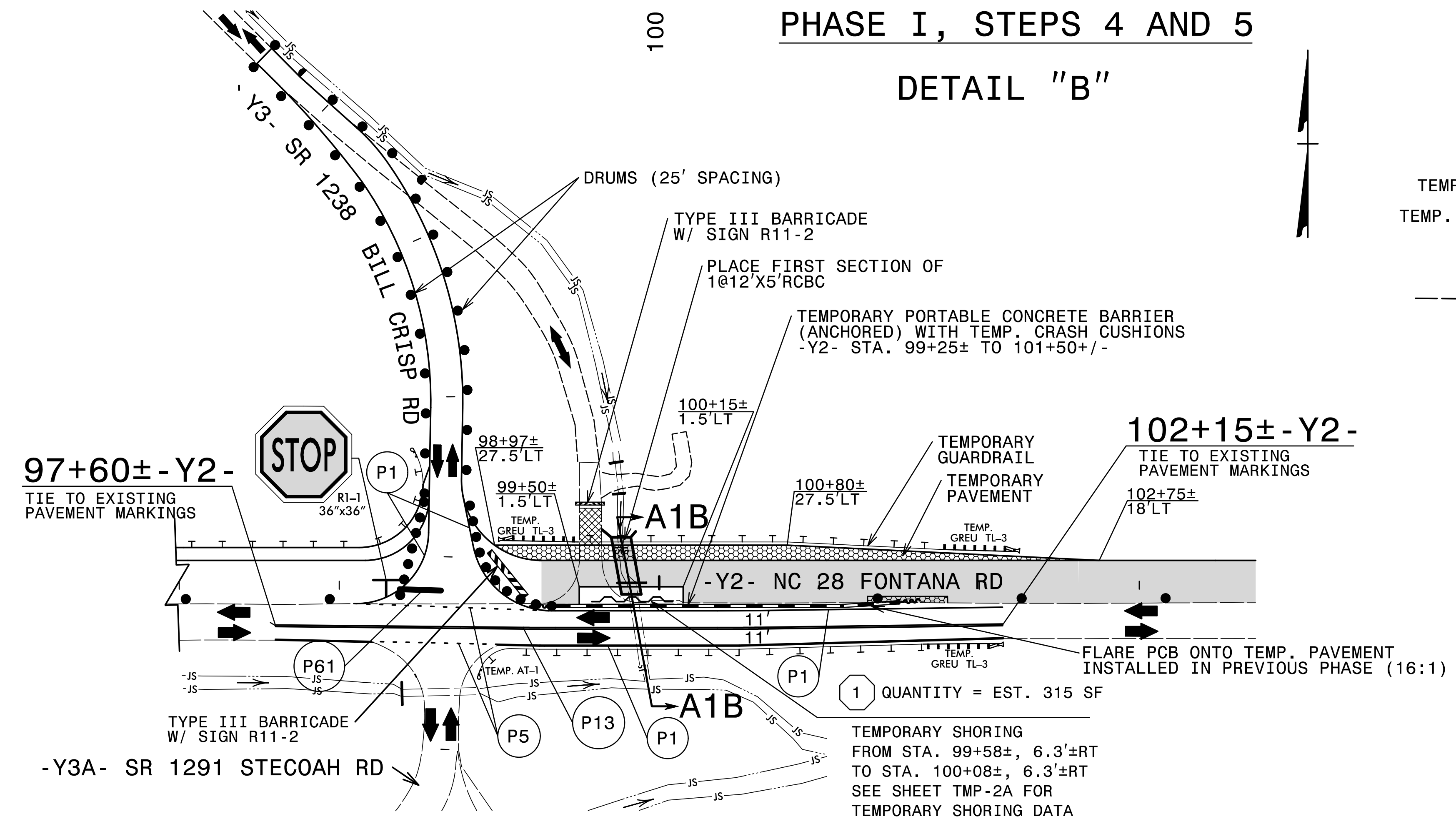

**SECTION A1B-A1B  
-Y2- STA 99+82±**

APPROVED: *Jimmy Terry*  
 DATE: 2/27/2026

SEAL

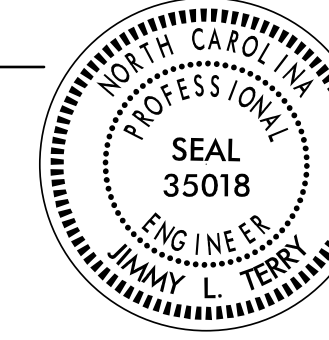
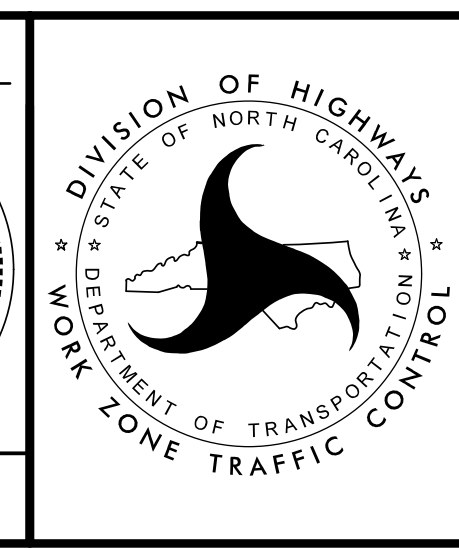



**PHASE I  
DETAIL  
NC 28**

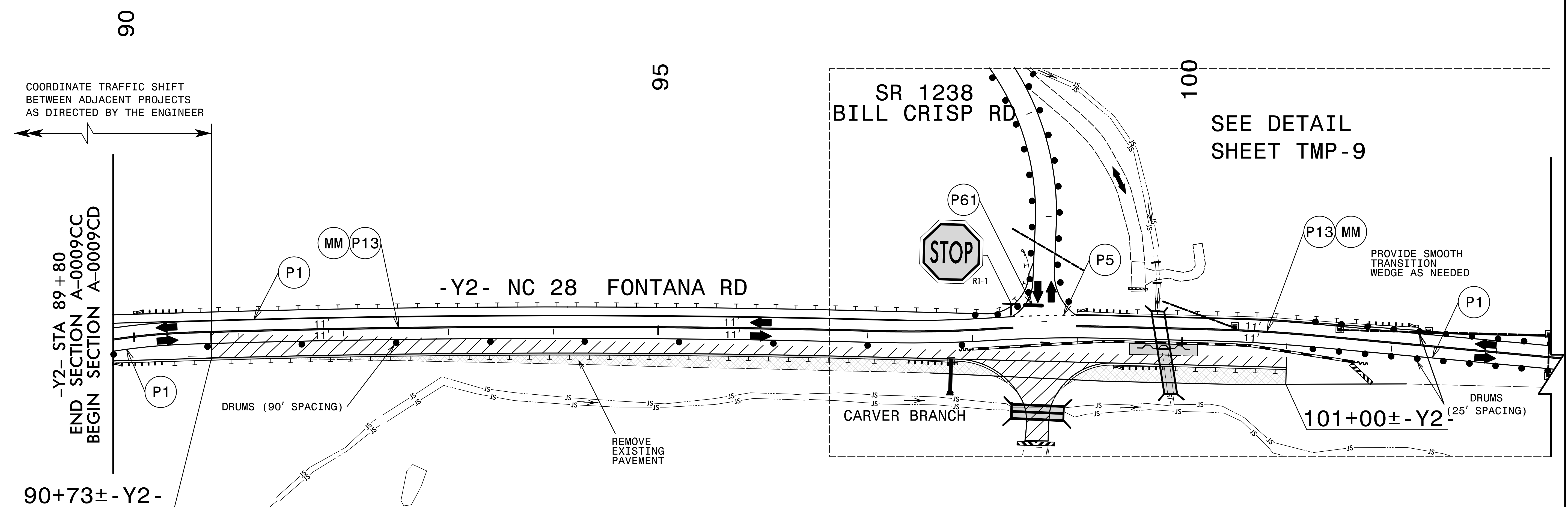

1/22/2026  
 X:\NC09\A-0009\Traffic\TrafficControl\TCPA-0009CD-A-0009CD-TC-TMP-07PHLDetail.dgn  
 User: jsmelvin

# PHASE II, STEP 1

|  |           |
|--|-----------|
| PROJ. REFERENCE NO.  | SHEET NO. |
| A-0009CD   | TMP-8     |
|  <b>TGS ENGINEERS</b><br>201 W. MARION ST. STE 200<br>SHELBY, NC 28150<br>PH: (704) 476-0003<br>CORP. LICENSE NO.: C-0275 |           |



1/22/2026 X:\CADD\A-0009\Traffic\TrafficControl\TCP\A-0009CD\A-0009CD-TC\_TMP\_08\PH2\_S1.dgn User:jsmevin

-  PROPOSED CONSTRUCTION
-  WEDGING EXISTING PAVEMENT

SEE SHEET TMP-1A FOR TEMPORARY PAVEMENT MARKING SCHEDULE

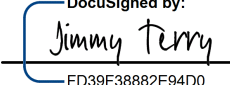
APPROVED: 

DATE: 2/27/2026

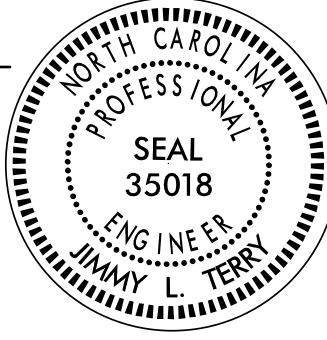

**DOCUMENT NOT CONSIDERED FINAL UNLESS ALL SIGNATURES COMPLETED**



## PHASE II STEP 1 NC 28

# PHASE II, STEP 1A

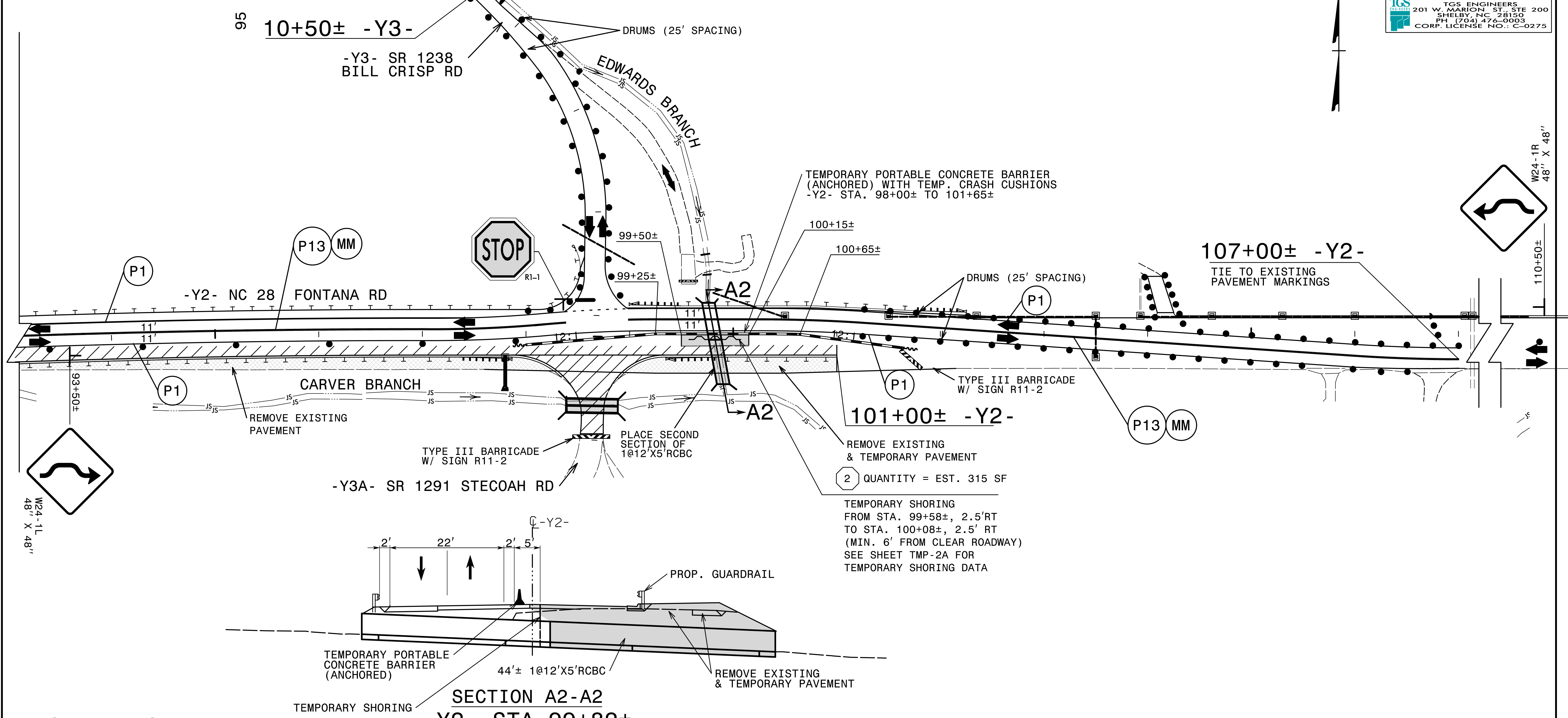

# PHASE II, STEP 1B

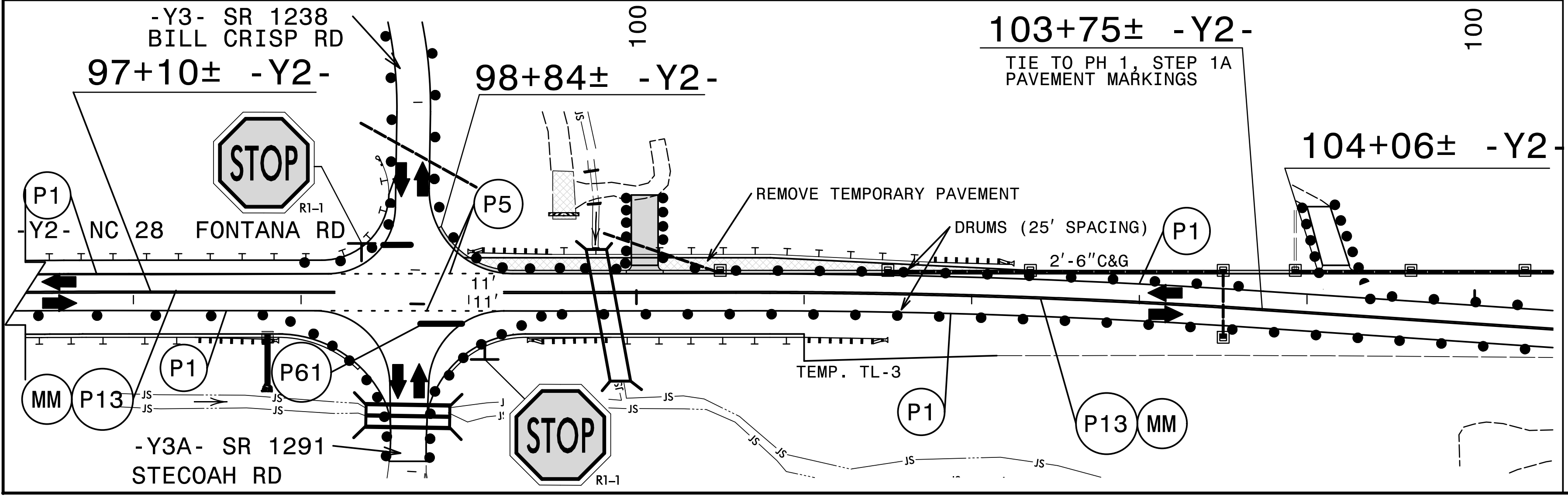

SEE EROSION CONTROL PLANS FOR CULVERT CONSTRUCTION SEQUENCE.  
SEE TMP-1A FOR TEMPORARY PAVEMENT MARKING SCHEDULE

APPROVED: *Jimmy Terry*  
DATE: 2/27/2026

SEAL

DOCUMENT NOT CONSIDERED FINAL UNLESS ALL SIGNATURES COMPLETED

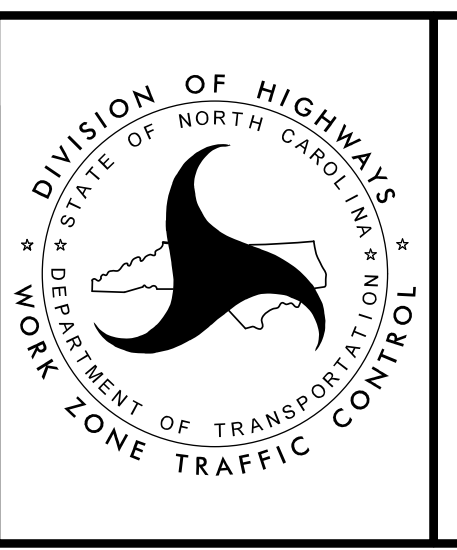

DIVISION OF HIGHWAYS  
STATE OF NORTH CAROLINA  
DEPARTMENT OF TRANSPORTATION  
WORK ZONE TRAFFIC CONTROL

**PHASE II  
STEP 1 DETAIL  
NC 28**

1/22/2026  
 X:\NC\A-0009\Traffic\TrafficControl\TCP\A-0009CD-1C-TMP-09\PH2\_Detail.dgn  
 User: jsmelvin

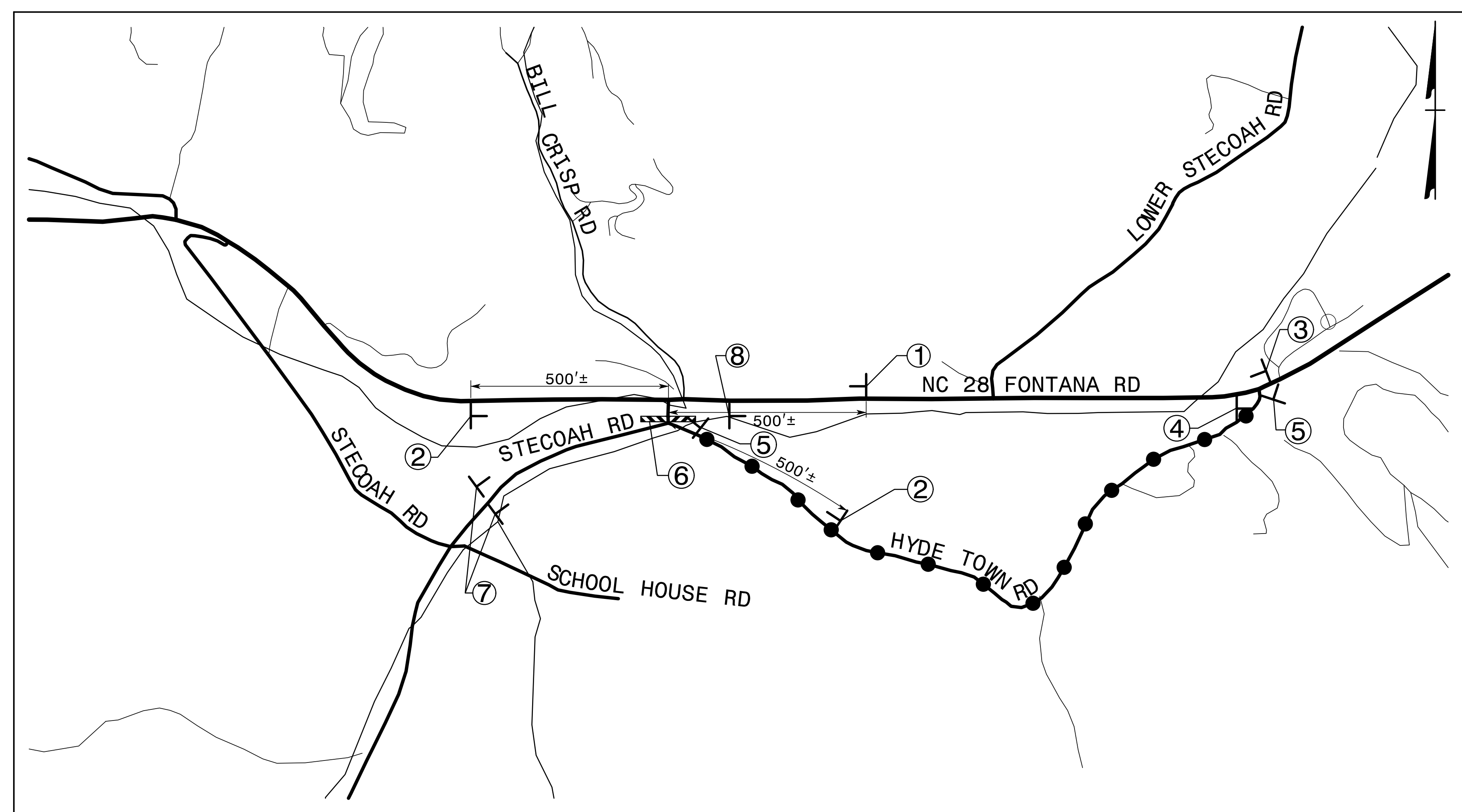

**DETOUR: STECOAH RD**

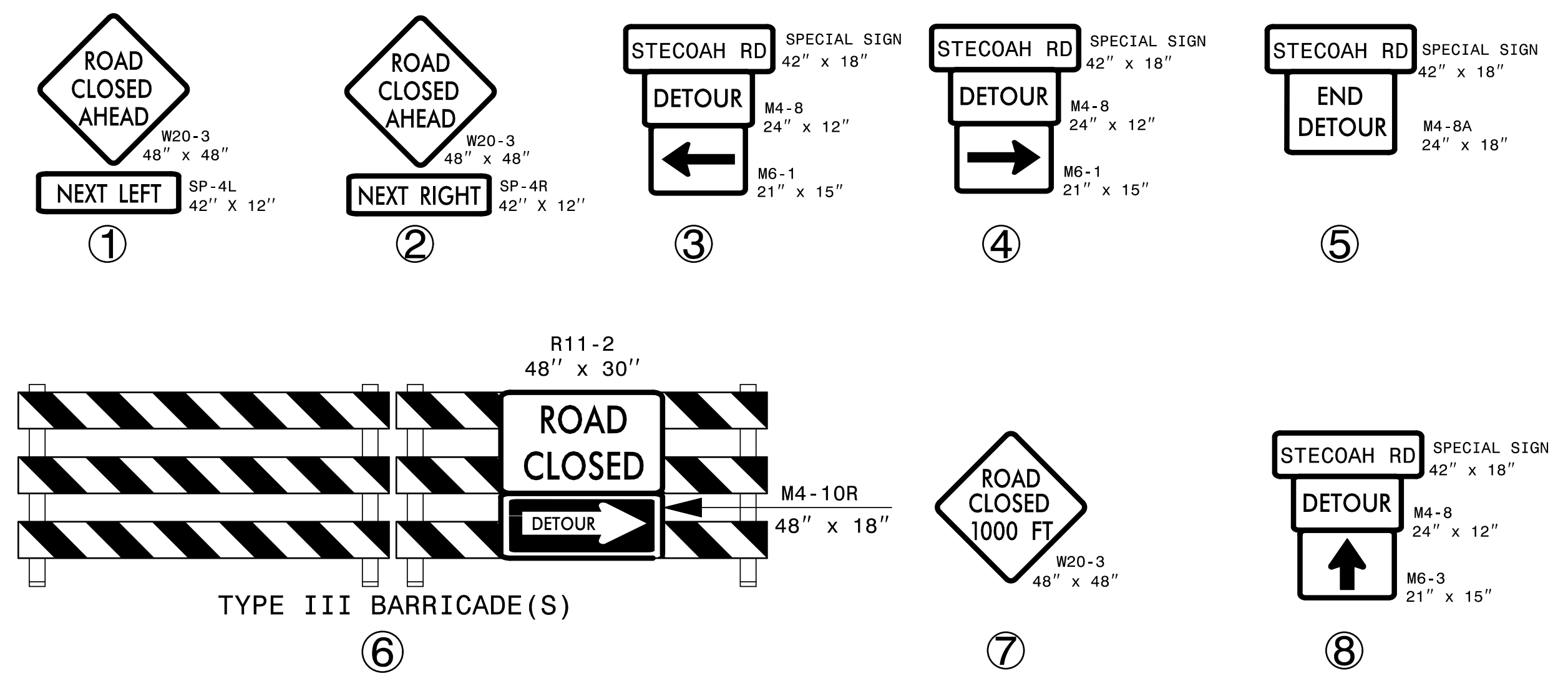
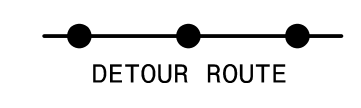

SEE SHEET TMP-2B FOR SPECIAL SIGN LAYOUT

I:\22\2026\A-0009\Traffic\TrafficComtrd\TCP\A-0009CD\A-0009CD-TC\_TMP\_10\PH2\_Det.dwg  
 User: jsmelvin

APPROVED: Jimmy Perry  
FD39F3882E94D0

DATE: 2/27/2026

SEAL

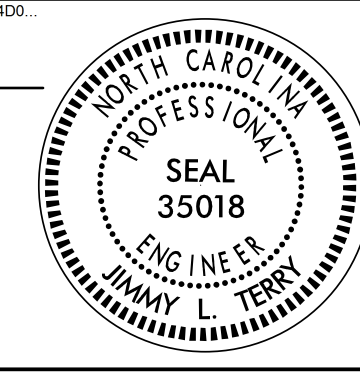
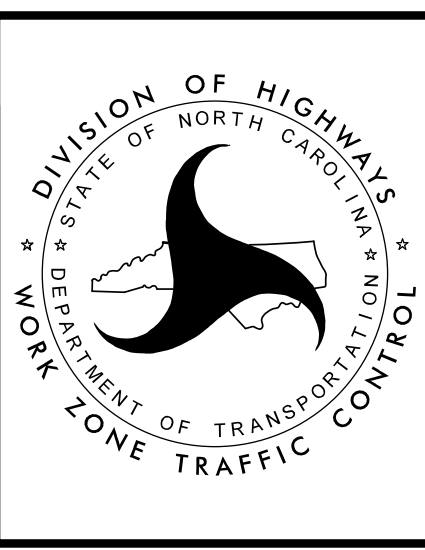





**PHASE II**  
**STEP 1 DETAIL**  
**OFF-SITE DETOUR**  
**STECOAH RD**

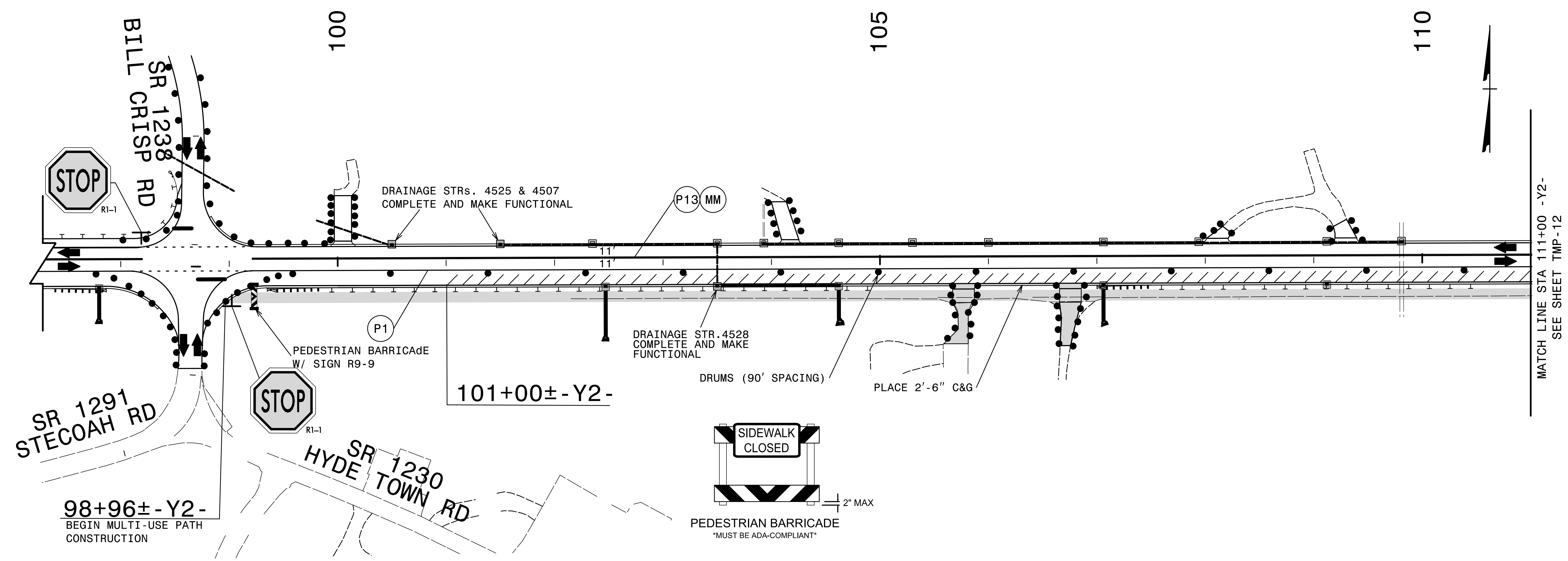

**DOCUMENT NOT CONSIDERED FINAL**  
**UNLESS ALL SIGNATURES COMPLETED**

# PHASE II, STEP 2

|   |           |
|---|-----------|
| PROJ. REFERENCE NO.   | SHEET NO. |
| A-0009CD  | TMP-11    |
|  <b>TGS ENGINEERS</b><br>201 W. MARION ST., STE 200<br>SHELBY, NC 28150<br>PH: (704) 476-0003<br>CORP. LICENSE NO.: C-0275 |           |

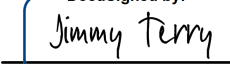
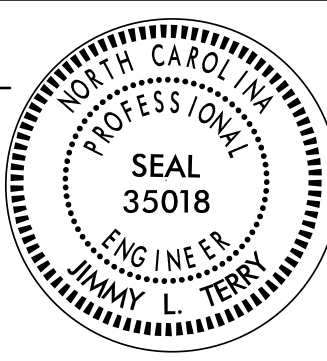

 PROPOSED CONSTRUCTION  
 WEDGING EXISTING PAVEMENT  
 SEE TMP-1A FOR TEMPORARY PAVEMENT MARKING SCHEDULE



|  |   |   |  |
|--|---|---|--|
| APPROVED: <br>DATE: 2/27/2026 |  |  | <h2>PHASE II</h2> <h3>STEP 2</h3> <p>NC 28</p> |
| <p><b>DOCUMENT NOT CONSIDERED FINAL UNLESS ALL SIGNATURES COMPLETED</b></p>  |   |   |  |

1/22/2026  
 X:\NCDOT\VA-0009\TrafficControl\TCP\VA-0009CD\A-0009CD\_TC\_TMP\_II\PH2\_S21.dgn  
 User: smelvin

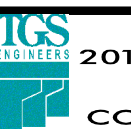
# PHASE II, STEP 2

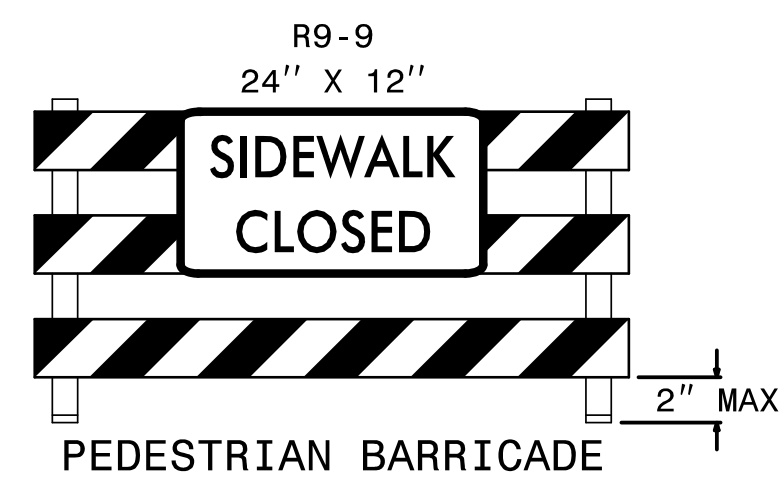
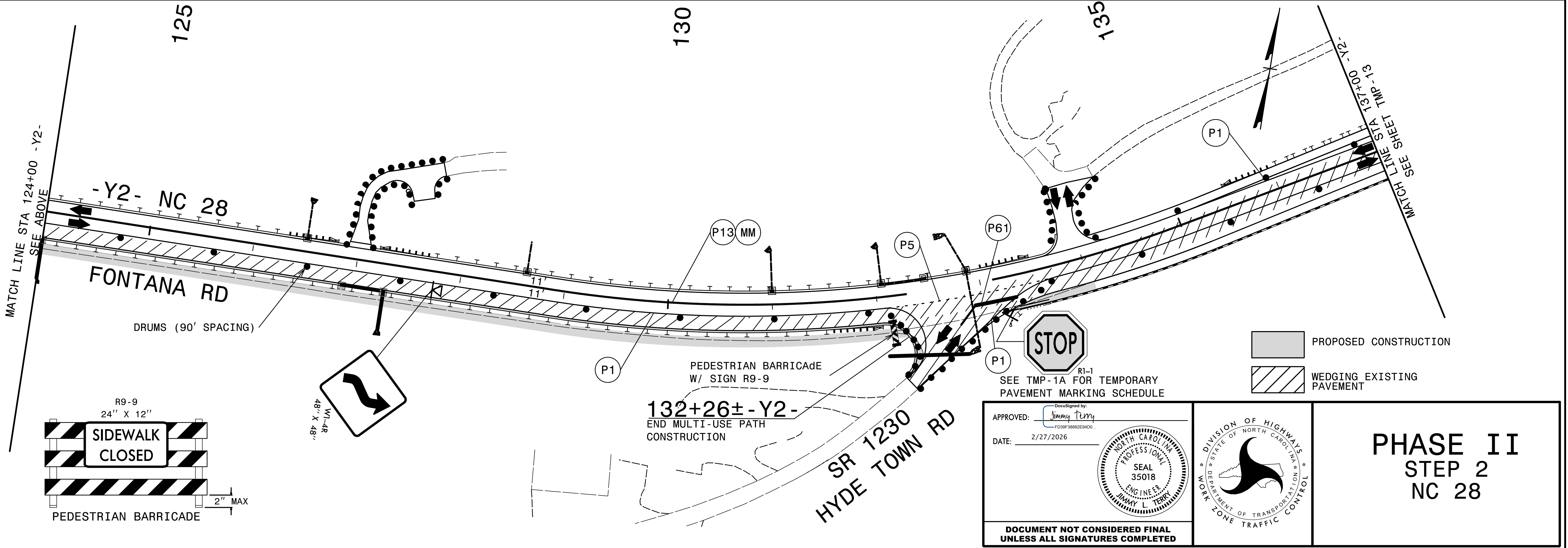
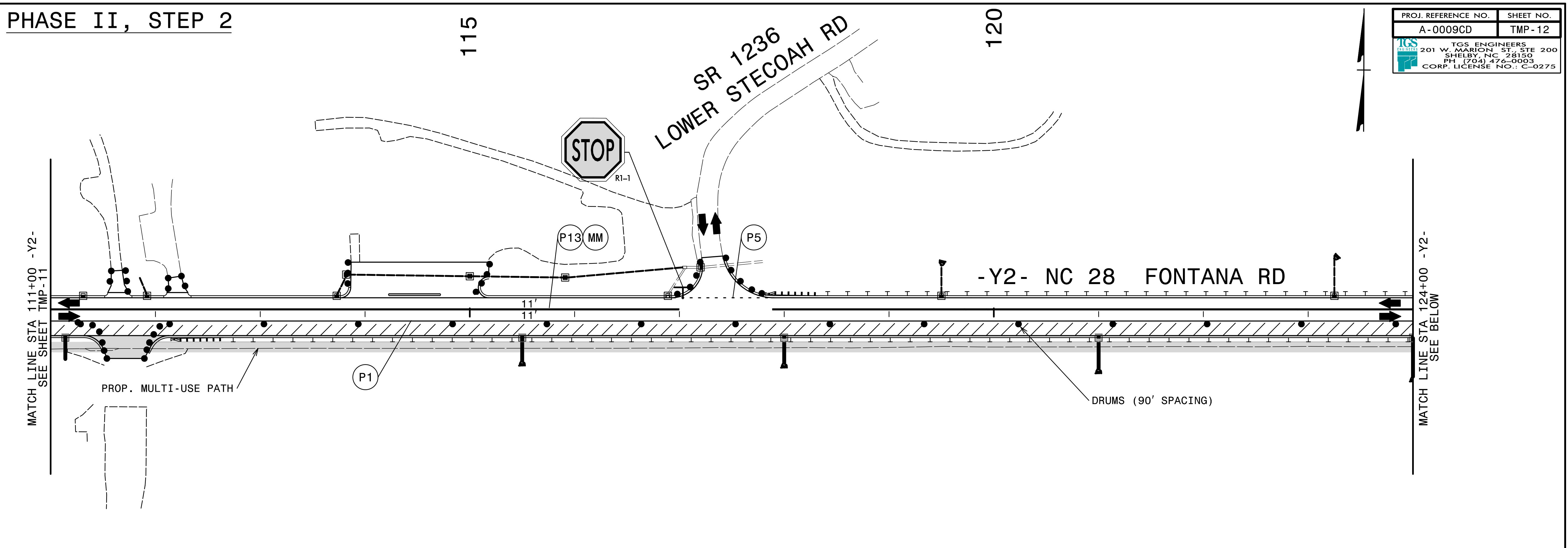
|   |           |
|---|-----------|
| PROJ. REFERENCE NO.   | SHEET NO. |
| A-0009CD  | TMP-12    |
|  <b>TGS ENGINEERS</b><br>201 W. MARION ST. STE 200<br>SHELBY, NC 28150<br>PH (704) 474-0003<br>CORP. LICENSE NO.: C-0275 |           |

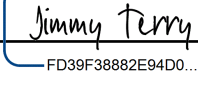
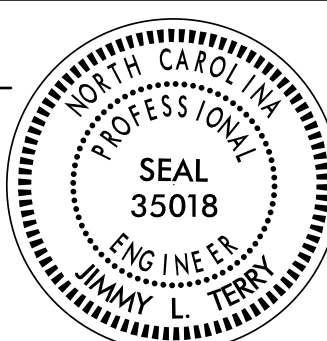

 PROPOSED CONSTRUCTION  
 WEDGING EXISTING PAVEMENT

APPROVED:   
 DATE: 2/27/2026  
  
 DOCUMENT NOT CONSIDERED FINAL  
 UNLESS ALL SIGNATURES COMPLETED

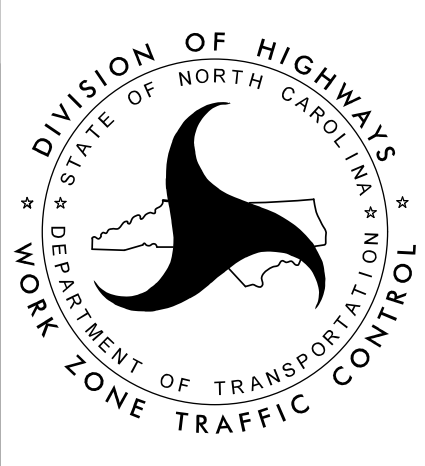

**PHASE II**  
**STEP 2**  
**NC 28**

1/22/2026  
 V:\2026\A-0009\Traffic\TrafficControl\TCP\A-0009CD-TC-TMP-12(PH2-S2).dgn  
 User: jsmelvin

# PHASE II, STEP 2



140

145

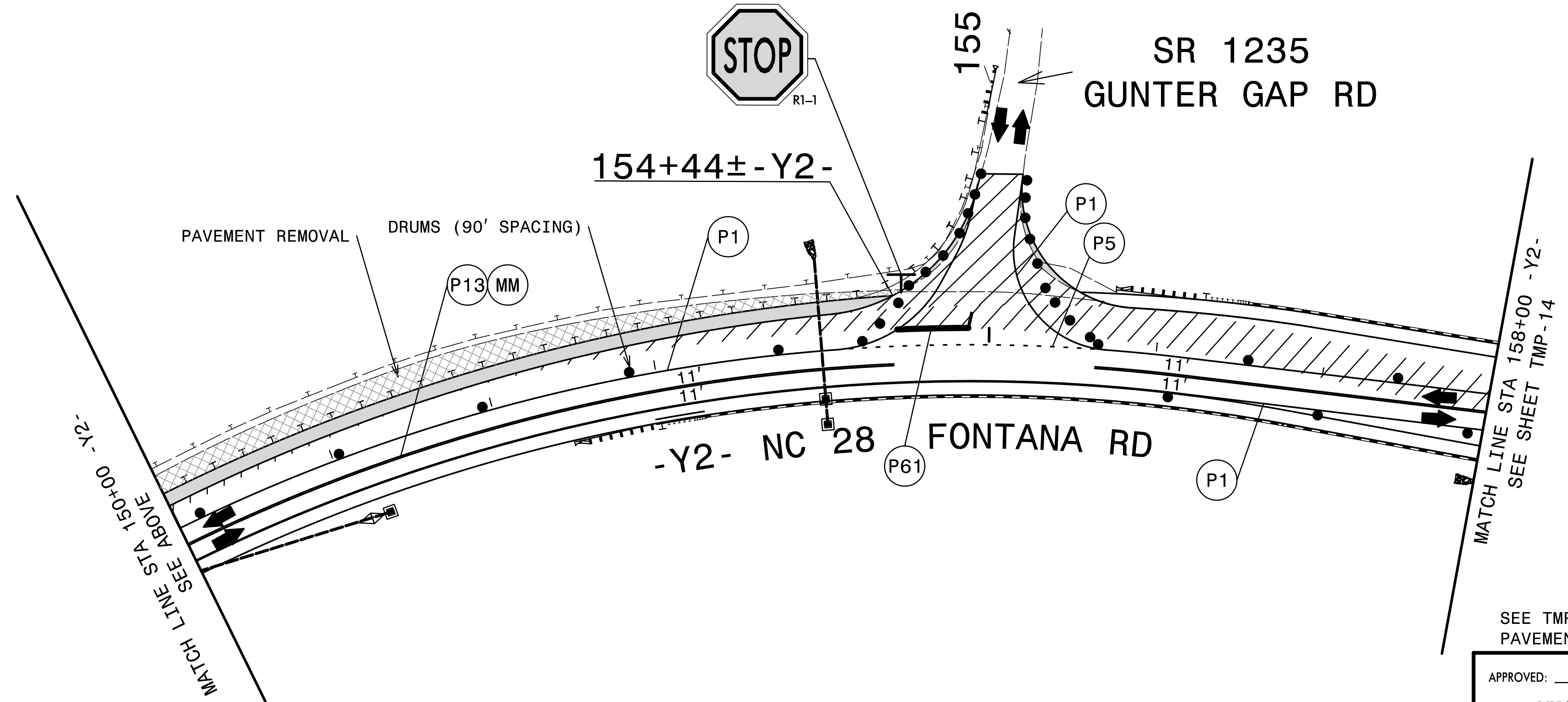
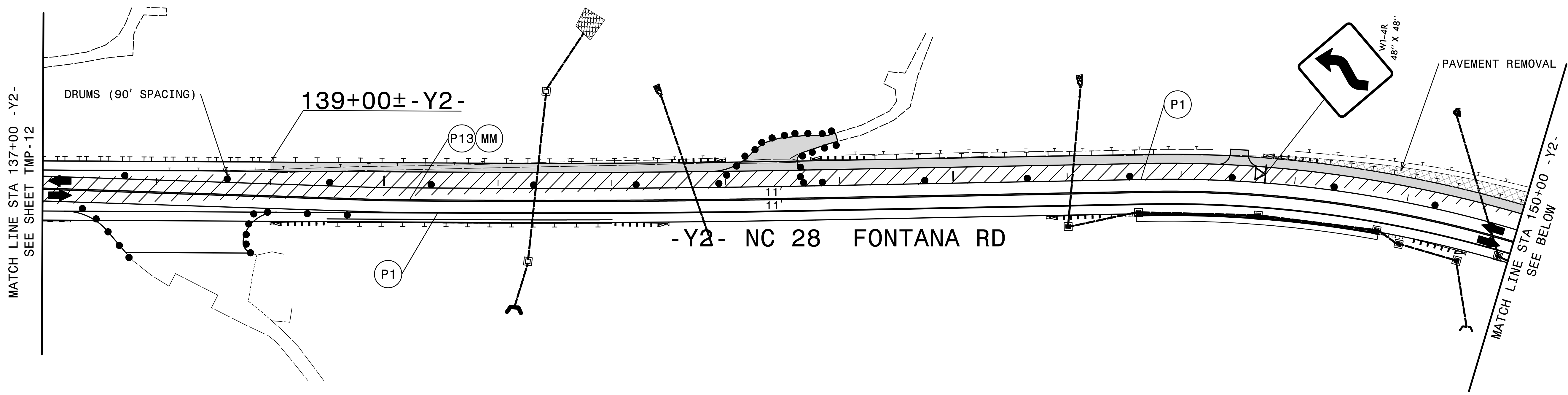
|   |                     |
|---|---------------------|
| PROJ. REFERENCE NO.<br>A-0009CD   | SHEET NO.<br>TMP-13 |
|  <b>TGS ENGINEERS</b><br>201 W. MARION ST. STE 200<br>SHELBY, NC 28150<br>PH (704) 476-0003<br>CORP. LICENSE NO.: C-0275 |                     |



SEE TMP-1A FOR TEMPORARY PAVEMENT MARKING SCHEDULE

-  PROPOSED CONSTRUCTION
-  WEDGING EXISTING PAVEMENT

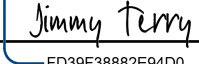
APPROVED:   
 2/27/2026

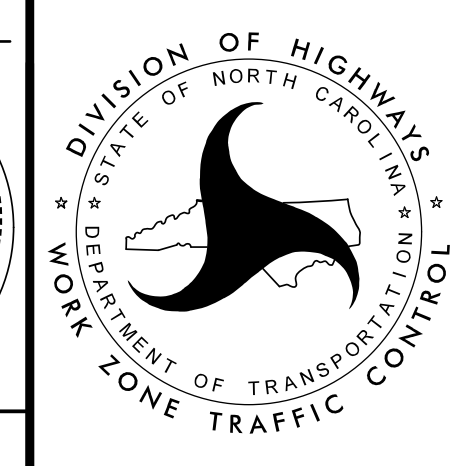
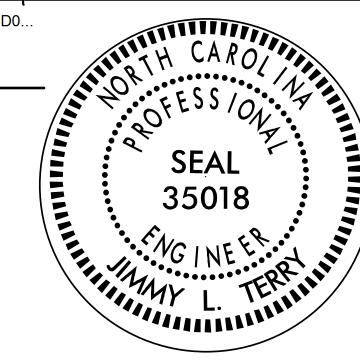

**PHASE II**  
**STEP 2**  
**NC 28**

**DOCUMENT NOT CONSIDERED FINAL  
 UNLESS ALL SIGNATURES COMPLETED**

1/22/2026  
 V:\2026\A-0009\Traffic\TrafficControl\TCP\A-0009CD\A-0009CD-TC\_TMP\_13(PH2\_S2).dgn  
 User: jsmelvin

# PHASE II, STEP 2

|   |           |
|---|-----------|
| PROJ. REFERENCE NO.   | SHEET NO. |
| A-0009CD  | TMP-14    |
|  <b>TGS ENGINEERS</b><br>201 W. MARION ST. STE 200<br>SHELBY, NC 28150<br>PH (704) 476-0003<br>CORP. LICENSE NO.: C-0275 |           |

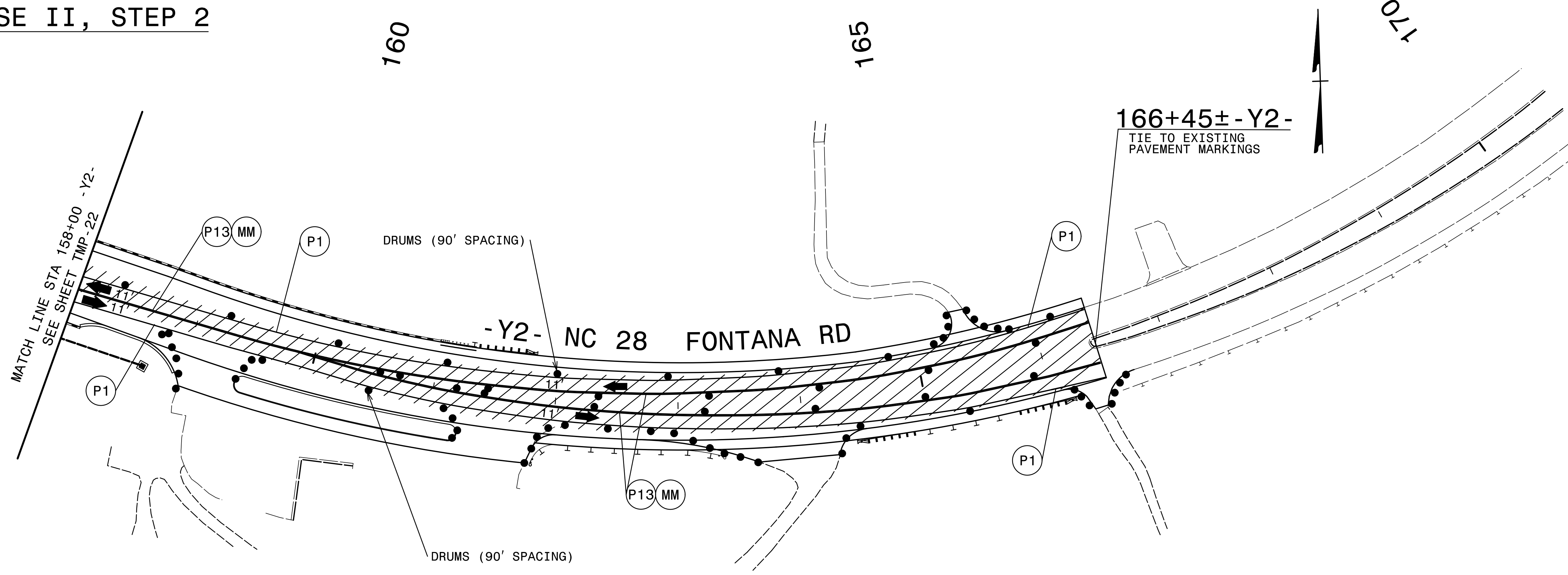

1/22/2026  
 X:\CADD\A-0009\Traffic\TrafficComtrd\TCP\A-0009CD\A-0009CD-TC\_TMP\_14(PH2\_S2).dgn  
 User: jsmelvin

SEE TMP-1A FOR TEMPORARY PAVEMENT MARKING SCHEDULE

 WEDGING EXISTING PAVEMENT

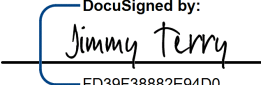
APPROVED:   
DocuSigned by: Jimmy Terry  
FD39F3882E94D0  
 2/27/2026

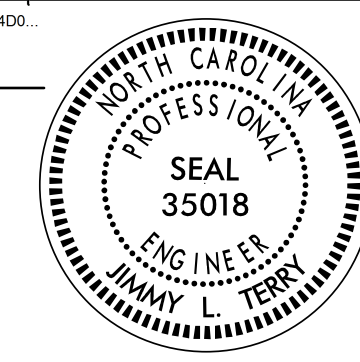

**DOCUMENT NOT CONSIDERED FINAL  
UNLESS ALL SIGNATURES COMPLETED**

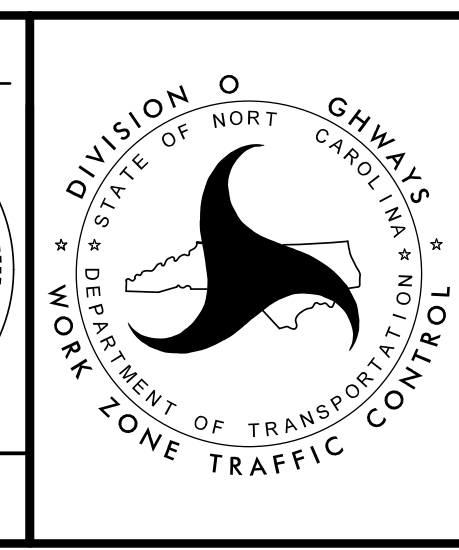

## PHASE II

### STEP 2

### NC 28

|   |           |
|---|-----------|
| PROJ. REFERENCE NO.   | SHEET NO. |
| A-0009CD  | TMP-15    |
|  <b>TGS ENGINEERS</b><br>201 W. MARION ST. STE 200<br>SHELBY, NC 28150<br>PH (704) 476-0003<br>CORP. LICENSE NO.: C-0275 |           |

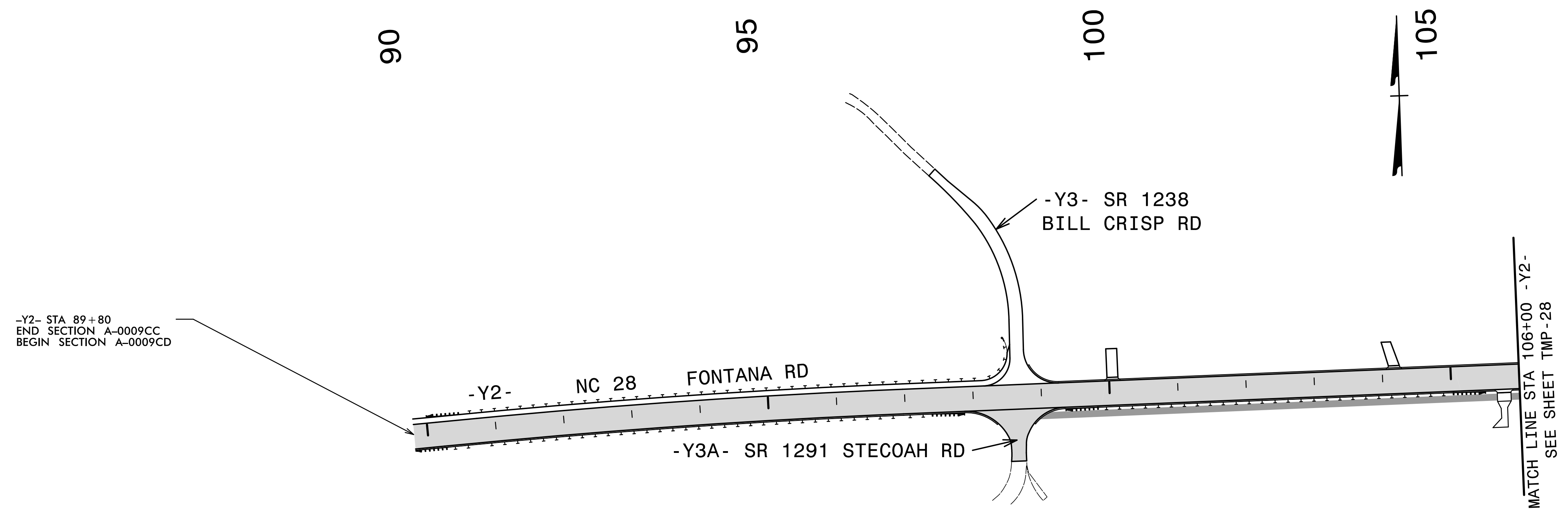

1/22/2026  
 X:\CADD\A-0009\Traffic\TrafficContr\TCP\A-0009CD\A-0009CD.TC.TMP\_IS(PH3).dgn  
 User: jsmelvin

SEE PAVEMENT MARKING PLANS FOR FINAL PAVEMENT MARKING LAYOUT

 PROPOSED CONSTRUCTION  
 FINAL LAYER OF SURFACE COURSE

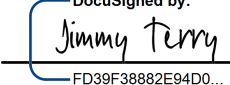
APPROVED: 

DATE: 2/27/2026

SEAL

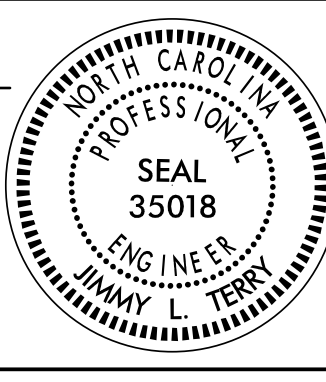

**DOCUMENT NOT CONSIDERED FINAL  
UNLESS ALL SIGNATURES COMPLETED**

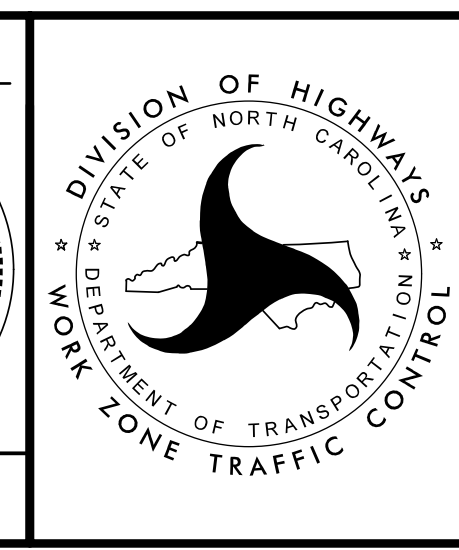

**PHASE III**  
**NC 143/ NC 28**

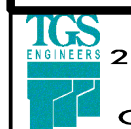
|   |           |
|---|-----------|
| PROJ. REFERENCE NO.   | SHEET NO. |
| A-0009CD  | TMP-16    |
|  <b>TGS ENGINEERS</b><br>201 W. MARION ST. STE 200<br>SHELBY, NC 28150<br>PH (704) 476-0003<br>CORP. LICENSE NO.: C-0275 |           |

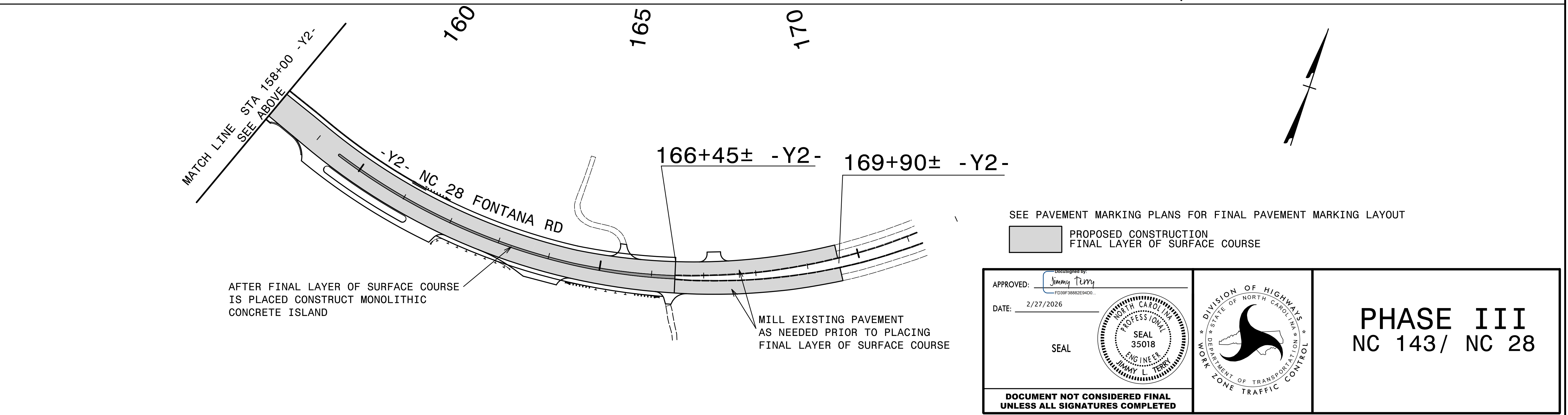
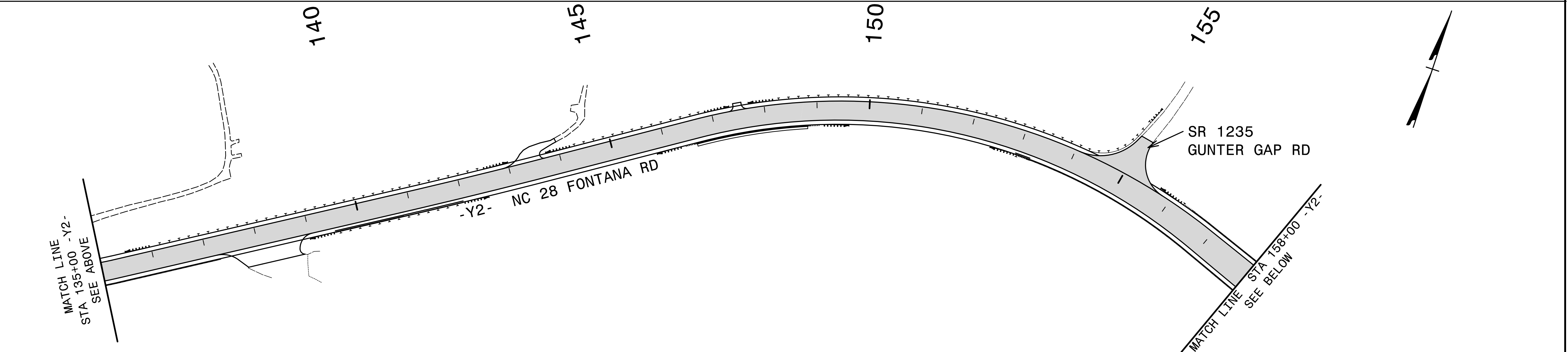
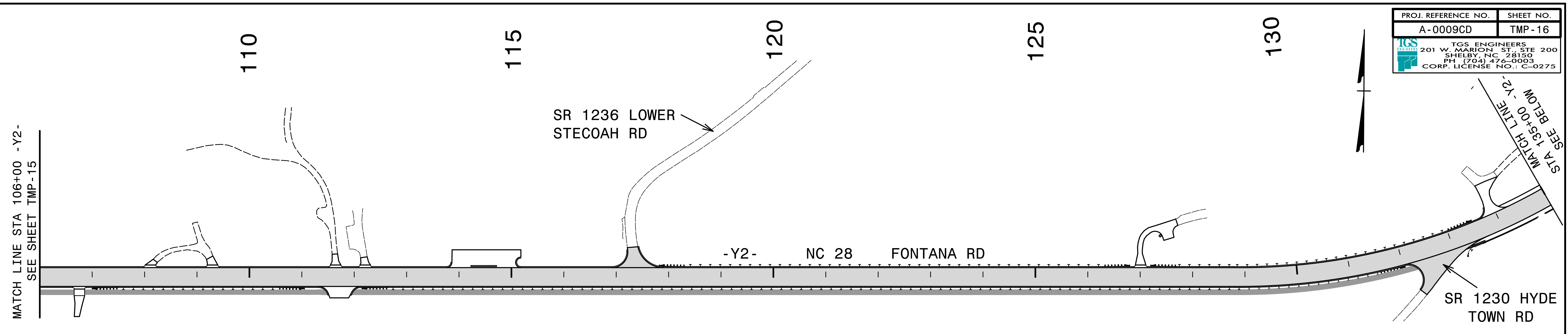

AFTER FINAL LAYER OF SURFACE COURSE IS PLACED CONSTRUCT MONOLITHIC CONCRETE ISLAND

MILL EXISTING PAVEMENT AS NEEDED PRIOR TO PLACING FINAL LAYER OF SURFACE COURSE

SEE PAVEMENT MARKING PLANS FOR FINAL PAVEMENT MARKING LAYOUT

 PROPOSED CONSTRUCTION  
FINAL LAYER OF SURFACE COURSE

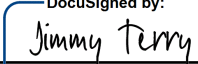
APPROVED:   
 DATE: 2/27/2026  
 SEAL

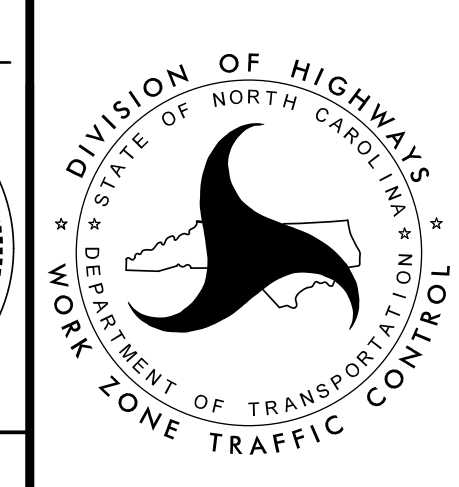
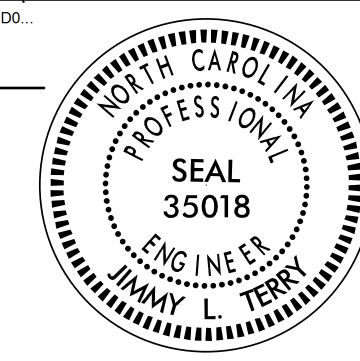

**PHASE III**  
 NC 143/ NC 28

**DOCUMENT NOT CONSIDERED FINAL UNLESS ALL SIGNATURES COMPLETED**

1/22/2026  
 X:\NC\A-0009\Traffic\TrafficControl\TCP\A-0009CD\A-0009CD-TC\_TMP\_16(PH3).dgn  
 User: jsmelvin