

5/14/19

PROJECT REFERENCE NO.	SHEET NO.
A-0009CD	U0-6
THIS SHEET CORRESPONDS TO R0Y-48	

UTILITIES BY OTHERS

ALL PROPOSED UTILITY WORK SHOWN ON THIS SHEET WILL BE DONE BY OTHERS. NO PAYMENT WILL BE MADE TO THE CONTRACTOR FOR PROPOSED UTILITY WORK SHOWN ON THIS SHEET.

-Y2- CURVE DATA

PI Sta 142+30.76	PI Sta 152+17.13
$\Delta = 1' 24' 23.1''$ (LT)	$\Delta = 5' 14' 50.1''$ (RT)
$D = 0' 28' 38.9''$	$D = 5' 2' 17.1''$
$L = 294.56'$	$L = 1,013.07'$
$T = 147.29'$	$T = 548.10'$
$R = 12,000.00'$	$R = 1,070.00'$
SE = NC	SE = 0.08
DS = 60 MPH	DS = 55 MPH

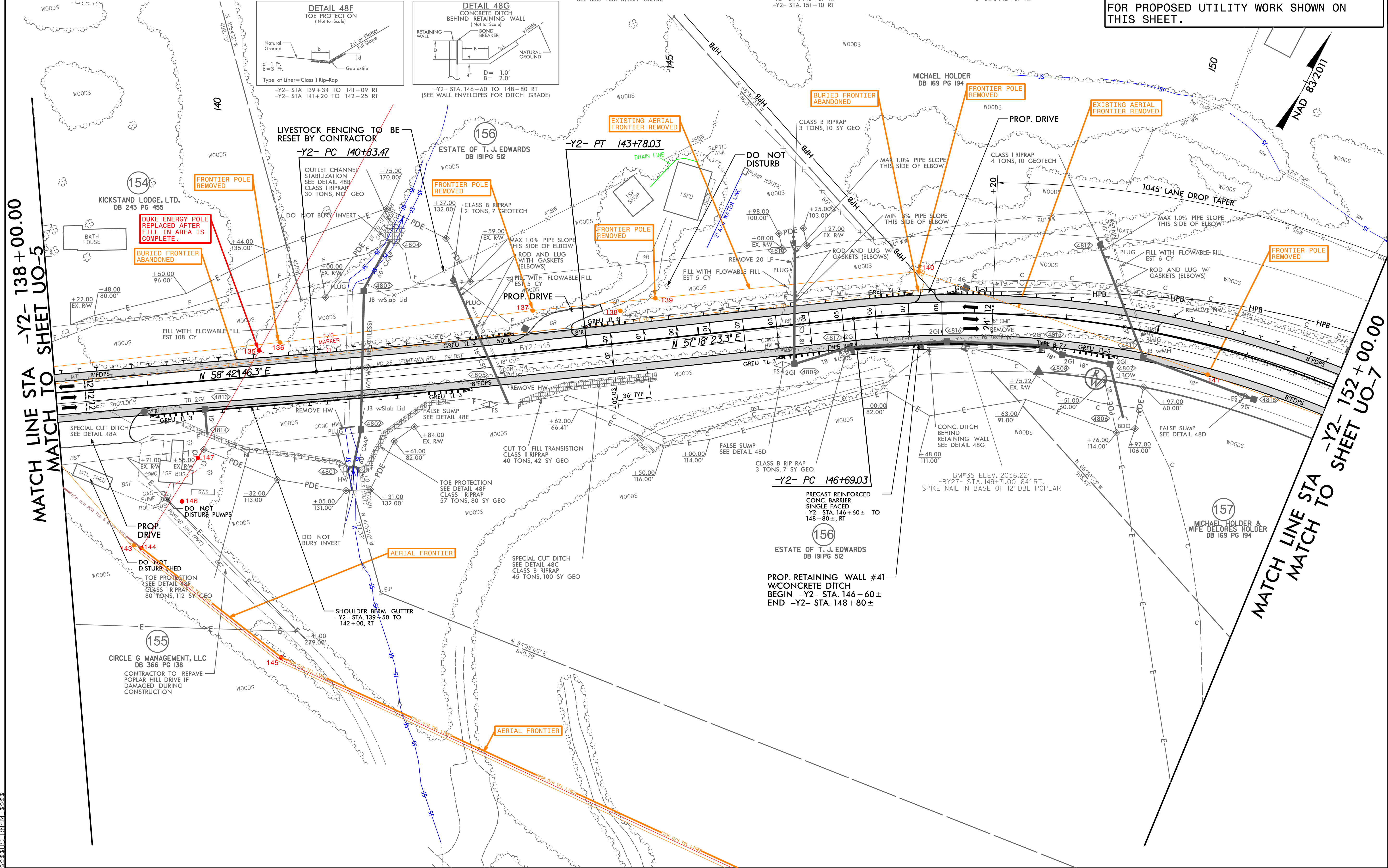
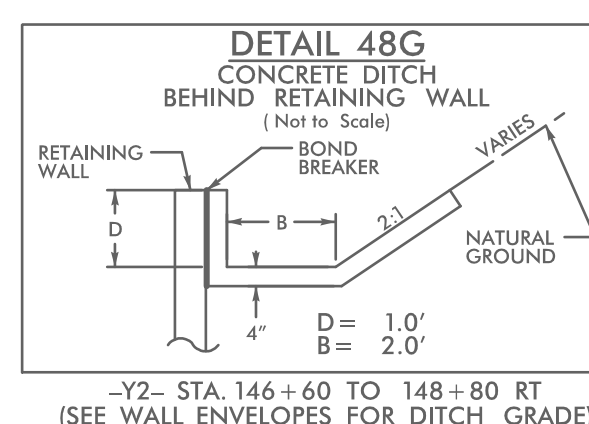
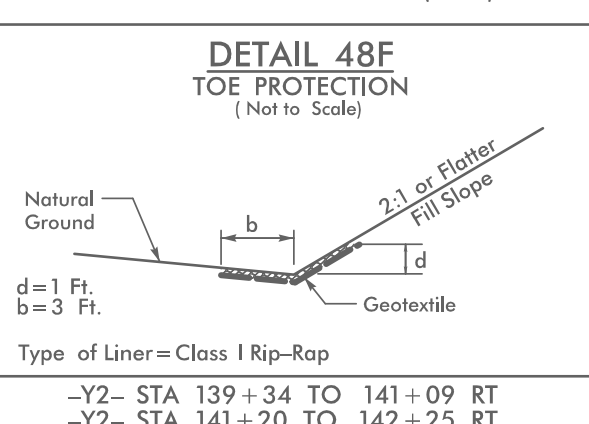
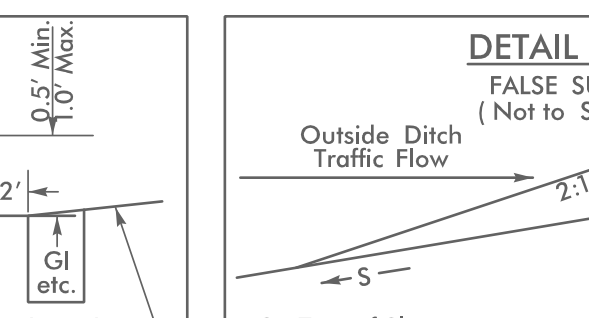
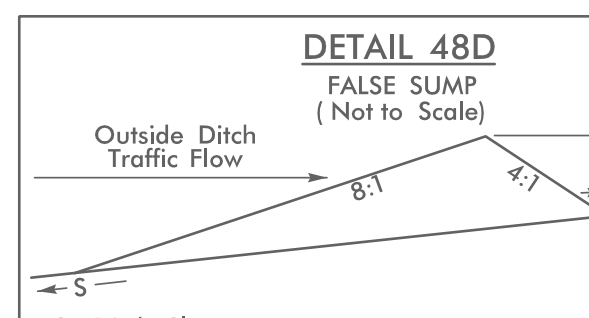
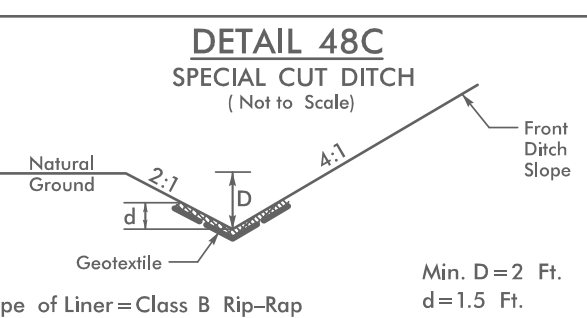
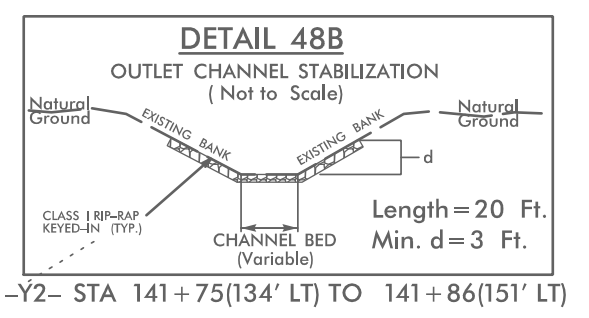
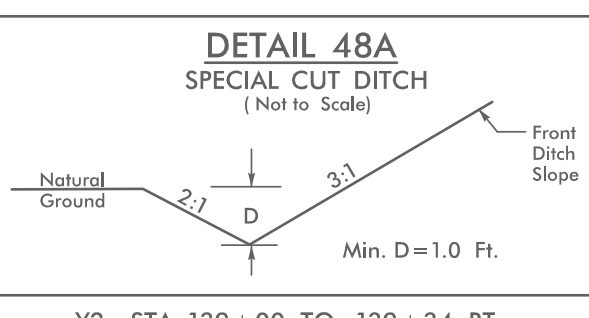

MATCH LINE STA -Y2- 138 + 00.00
MATCH TO SHEET UO-5

MATCH LINE STA -Y2- 152 + 00.00
MATCH TO SHEET UO-7

1
2
3
4
5
6
7
8
9
10
11
12
13
14
15
16
17
18
19
20
21
22
23
24
25
26
27
28
29
30
31
32
33
34
35
36
37
38
39
40
41
42
43
44
45
46
47
48
49
50
51
52
53
54
55
56
57
58
59
60
61
62
63
64
65
66
67
68
69
70
71
72
73
74
75
76
77
78
79
80
81
82
83
84
85
86
87
88
89
90
91
92
93
94
95
96
97
98
99
100