

DocuSigned by:  
D. Matthew Brewer 04/09/2026

DOCUMENT NOT CONSIDERED FINAL UNLESS ALL SIGNATURES COMPLETED

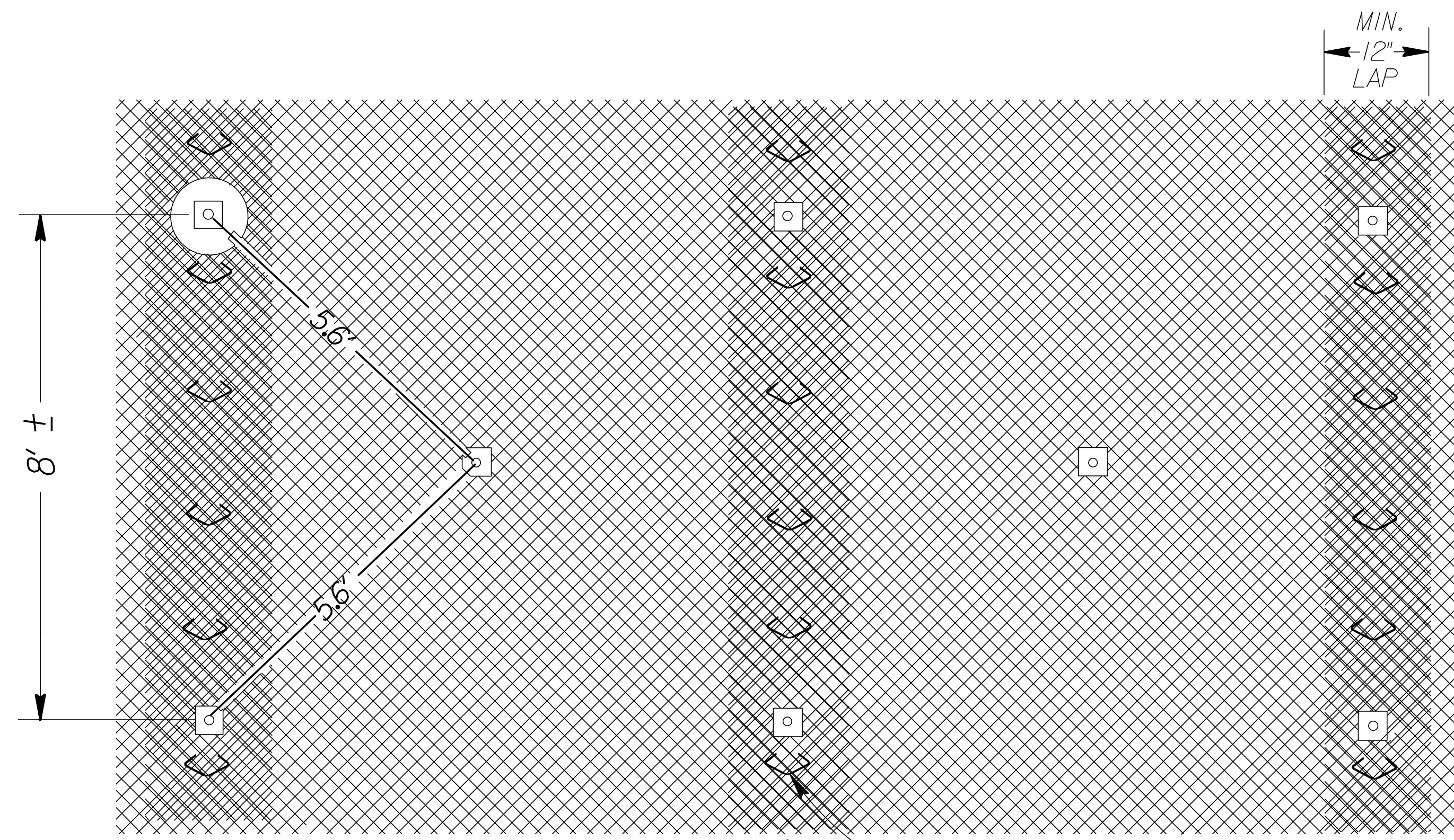
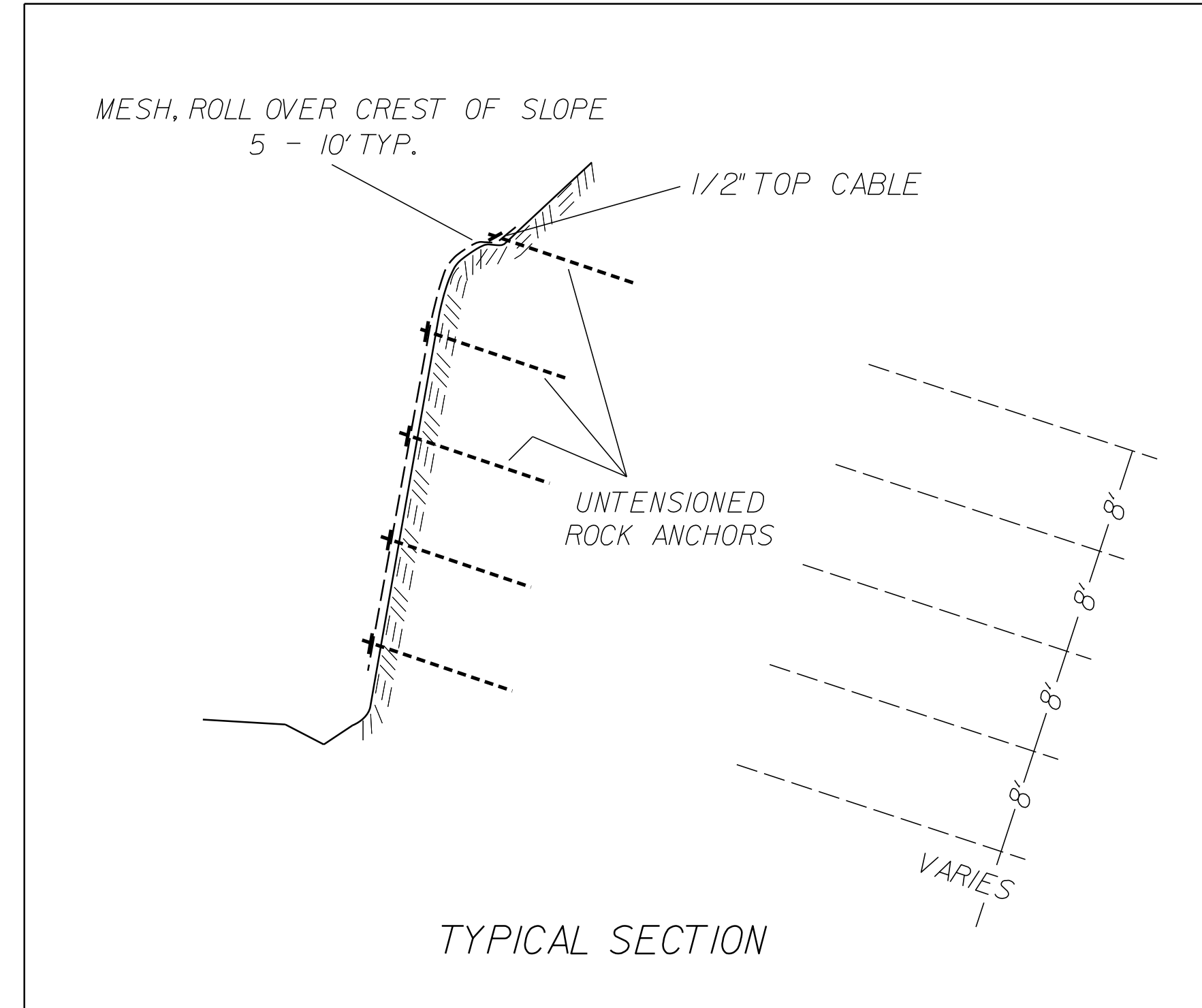

MESH: SEE SPECIAL PROVISION "SLOPE STABILIZATION" "WIRE MESH" TYPE 1 OR TYPE 2

DETAIL OF WIRE MESH

N.T.S.

NOTES:

- 1) WIRE MESH SHALL BE INSTALLED ON SLOPES AT LOCATIONS AS DIRECTED BY THE ENGINEER.

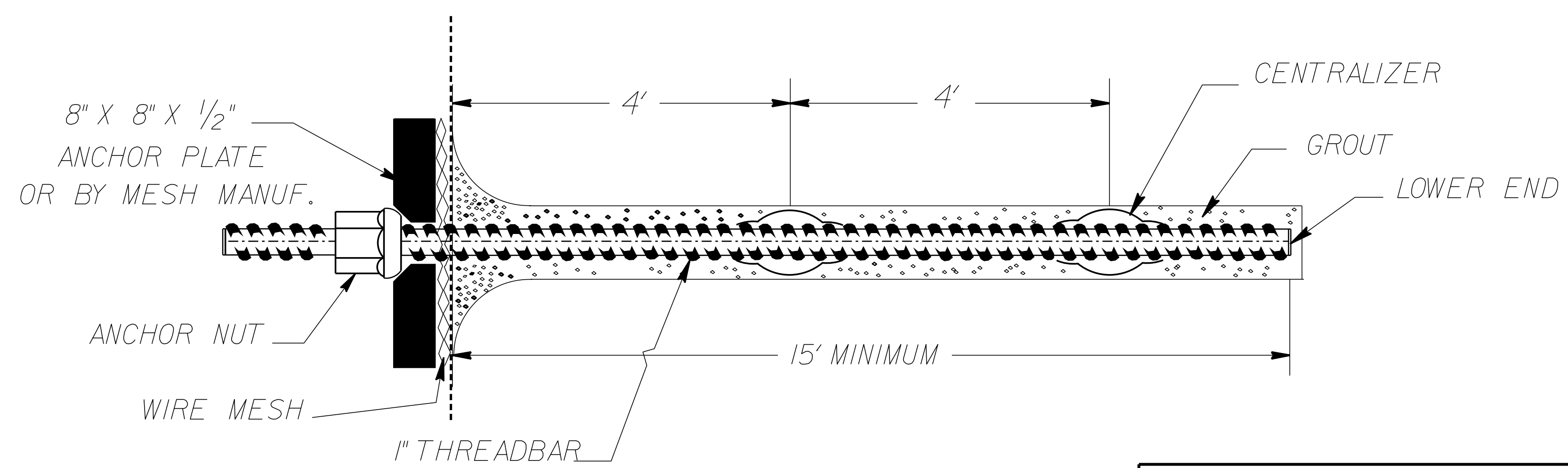

ANCHOR FOR WIRE MESH

N.T.S.

ESTIMATED QUANTITIES	
WIRE MESH (TYPE 1)	750 SY
WIRE MESH (TYPE 2)	750 SY
UNTENSIONED ROCK ANCHOR FOR WIRE MESH	3,000 LF

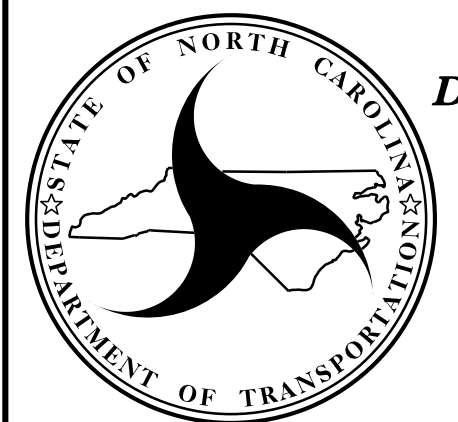

REVISIONS					
NO.	BY	DATE	NO.	BY	DATE
1			3		
2			4		