

CONTRACT: C204773 T.I.P.: B-6051 / U-6143

**STATE OF NORTH CAROLINA
DEPARTMENT OF TRANSPORTATION**

**PAVEMENT MARKING PLAN
GASTON / MECKLENBURG COUNTIES**

**LOCATION: BRIDGE NO. 91 OVER CATAWBA RIVER
ON US 29 /US 74 AND INTERSECTION
IMPROVEMENTS ON US 29 /US 74
(WILKINSON BLVD) AND NC 7 (CATAWBA ST)**

<small>TIP NO.</small> B-6051/U-6143	<small>SHEET NO.</small> PMP-1
<small>APPROVED:</small> <small>SCS0085EAF0045F</small>	
<small>DATE:</small> 4/7/2026	
DOCUMENT NOT CONSIDERED FINAL UNLESS ALL SIGNATURES COMPLETED	

ROADWAY STANDARD DRAWING

THE FOLLOWING ROADWAY STANDARDS AS APPEAR IN "ROADWAY STANDARD DRAWINGS" - N.C. DEPARTMENT OF TRANSPORTATION - RALEIGH, N.C., DATED JANUARY 2024 ARE APPLICABLE TO THIS PROJECT AND BY REFERENCE HEREBY ARE CONSIDERED A PART OF THESE PLANS:

<u>STD. NO.</u>	<u>TITLE</u>
1205.01	PAVEMENT MARKINGS - LINE TYPES AND OFFSETS
1205.02	PAVEMENT MARKINGS - TWO-LANE AND MULTILANE ROADWAYS
1205.04	PAVEMENT MARKINGS - INTERSECTIONS
1205.05	PAVEMENT MARKINGS - TURN LANES
1205.07	PAVEMENT MARKINGS - PEDESTRIAN CROSSWALKS
1205.08	PAVEMENT MARKINGS - SYMBOLS AND WORD MESSAGES
1205.09	PAVEMENT MARKINGS - PAINTED ISLANDS
1205.12	PAVEMENT MARKINGS - BRIDGES
1205.13	PAVEMENT MARKINGS - LANE REDUCTIONS
1205.15	PAVEMENT MARKINGS - REDUCED CONFLICT INTERSECTION
1250.01	RAISED PAVEMENT MARKERS - INSTALLATION SPACING
1251.01	RAISED PAVEMENT MARKERS - PERMANENT AND TEMPORARY
1261.01	GUARDRAIL AND BARRIER DELINEATORS - INSTALLATION SPACING
1262.01	GUARDRAIL END DELINEATION

GENERAL NOTES

THE FOLLOWING GENERAL NOTES APPLY AT ALL TIMES FOR THE DURATION OF THE CONSTRUCTION PROJECT, EXCEPT WHEN OTHERWISE NOTED IN THE PLAN, OR DIRECTED BY THE ENGINEER.

- A) INSTALL PAVEMENT MARKINGS AND PAVEMENT MARKERS ON THE FINAL SURFACE AS FOLLOWS:

<u>ROAD NAME</u>	<u>MARKING</u>	<u>MARKER</u>
-Y1-	THERMOPLASTIC	NONE
-L- (US 29/74) , -Y2-	THERMOPLASTIC	SNOWPLOWABLE POLYCARBONATE H-SHAPED
-Y3- CONCRETE SURFACES	THERMOPLASTIC POLYUREA	PERM. RAISED PERM. RAISED
- B) TIE PROPOSED PAVEMENT MARKING LINES TO EXISTING PAVEMENT MARKING LINES.
- C) REMOVE/REPLACE ANY CONFLICTING/DAMAGED PAVEMENT MARKINGS AND MARKERS.
- D) STOP BAR LOCATION AT NON-SIGNALIZED INTERSECTIONS MAY BE ADJUSTED AS DIRECTED BY THE ENGINEER.
- E) REMOVE ALL RESIDUE AND SURFACE LAITANCE BY ACCEPTABLE METHODS ON CONCRETE BRIDGE DECKS PRIOR TO PLACING POLYUREA PAVEMENT MARKING MATERIAL.
- F) UNLESS OTHERWISE SPECIFIED, HEATED-IN-PLACE THERMOPLASTIC MAY BE USED IN LIEU OF EXTRUDED THERMOPLASTIC FOR STOP BARS, SYMBOLS, CHARACTERS AND DIAGONALS. IF HEATED-IN-PLACE IS USED, IT SHALL BE PAID FOR USING THE EXTRUDED THERMOPLASTIC PAY ITEM.
- G) SEE ROADWAY PLANS FOR ALTERNATE CURB RAMP DESIGNS WHEN INDICATED ON PAVEMENT MARKING DETAIL SHEETS.

PAVEMENT MARKING SCHEDULE

<u>THERMOPLASTIC LINES</u>	<u>POLYUREA LINES</u>
T1 WHITE EDGELINE (4", 90 MIL)	V1 WHITE EDGELINE (4", 20 MIL)
T2 WHITE SOLID LANE LINE (4", 90 MIL)	V3 10 FT. WHITE SKIP (4", 20 MIL)
T3 10 FT. WHITE SKIP (4", 90 MIL)	V10 YELLOW EDGELINE (4", 20 MIL)
T4 3 FT.-9 FT./SP WHITE MINISKIP (4", 90 MIL)	
T5 2 FT.-6 FT./SP WHITE MINISKIP (4", 90 MIL)	
T10 YELLOW EDGELINE (4", 90 MIL)	
T13 YELLOW DOUBLE CENTER (4", 90 MIL)	
T40 WHITE GORELINE (8", 90 MIL)	
T41 WHITE DIAGONAL (8", 90 MIL)	
T51 WHITE DIAGONAL (12", 90 MIL)	
T61 WHITE STOPBAR (24", 90 MIL)	
T62 WHITE CROSSWALK LINE (24", 90 MIL)	
<u>THERMOPLASTIC SYMBOLS</u>	<u>PAVEMENT MARKERS</u>
T70 LEFT TURN ARROW (90 MIL)	MA PERMANENT RAISED (YELLOW & YELLOW)
T71 RIGHT TURN ARROW (90 MIL)	MB PERMANENT RAISED (CRYSTAL & RED)
T72 STRAIGHT ARROW (90 MIL)	ME SNOWPLOWABLE (YELLOW & YELLOW)
T74 COMBO. RIGHT/STRAIGHT ARROW (90 MIL)	MF SNOWPLOWABLE (CRYSTAL & RED)
T77 U-TURN ARROW (90 MIL)	
T79 MERGE ARROW (90 MIL)	

INDEX

<u>SHEET NO.</u>	<u>DESCRIPTION</u>
PMP-1	PAVEMENT MARKING PLAN TITLE
PMP-1A	SNOWPLOWABLE MARKER DETAIL
PMP-3-8	PAVEMENT MARKING DETAIL
PMP-3A-7A	CURB RAMP DETAIL

PLAN PREPARED BY: N.C.D.O.T. SIGNING AND DELINEATION UNIT

Kelvin L. Jordan SIGNING & DELINEATION REGIONAL ENGINEER
Jose G. Martinez, PE SIGNING & DELINEATION DESIGN ENGINEER III

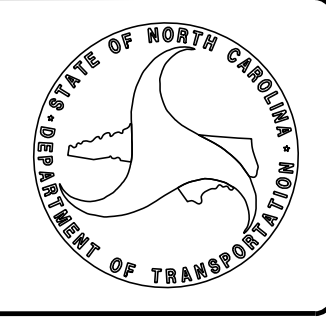

PLAN PREPARED BY: RK&K

Kevin Bisby, PE Project Engineer
Allen Tutt Sr. Designer

RK&K
P: (919) 878-9560
8601 Six Forks Road, Forum 1, Suite 700
Raleigh, North Carolina 27615-3960
NC License No. F-0112
Engineers | Construction Managers | Planners | Scientists
www.rkk.com
Responsive People | Creative Solutions

4/7/2026
B6051_PMP_PSH01.dgn
dssears

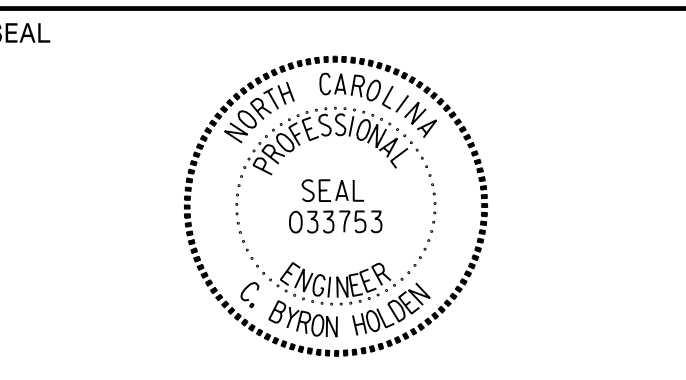

DOCUMENT NOT CONSIDERED FINAL
 UNLESS ALL SIGNATURES COMPLETED

TYPICAL PAVEMENT MARKER

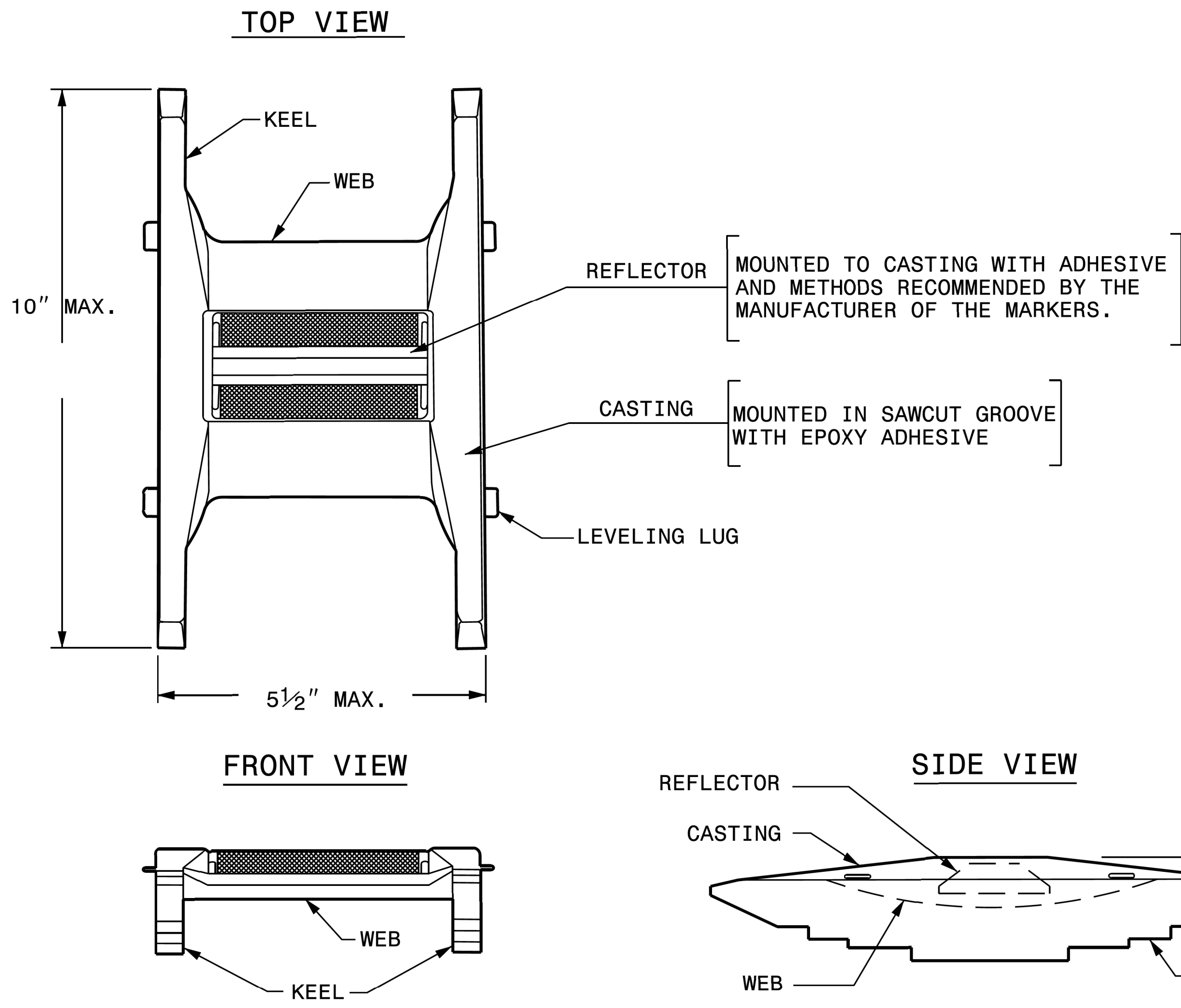

REFLECTOR

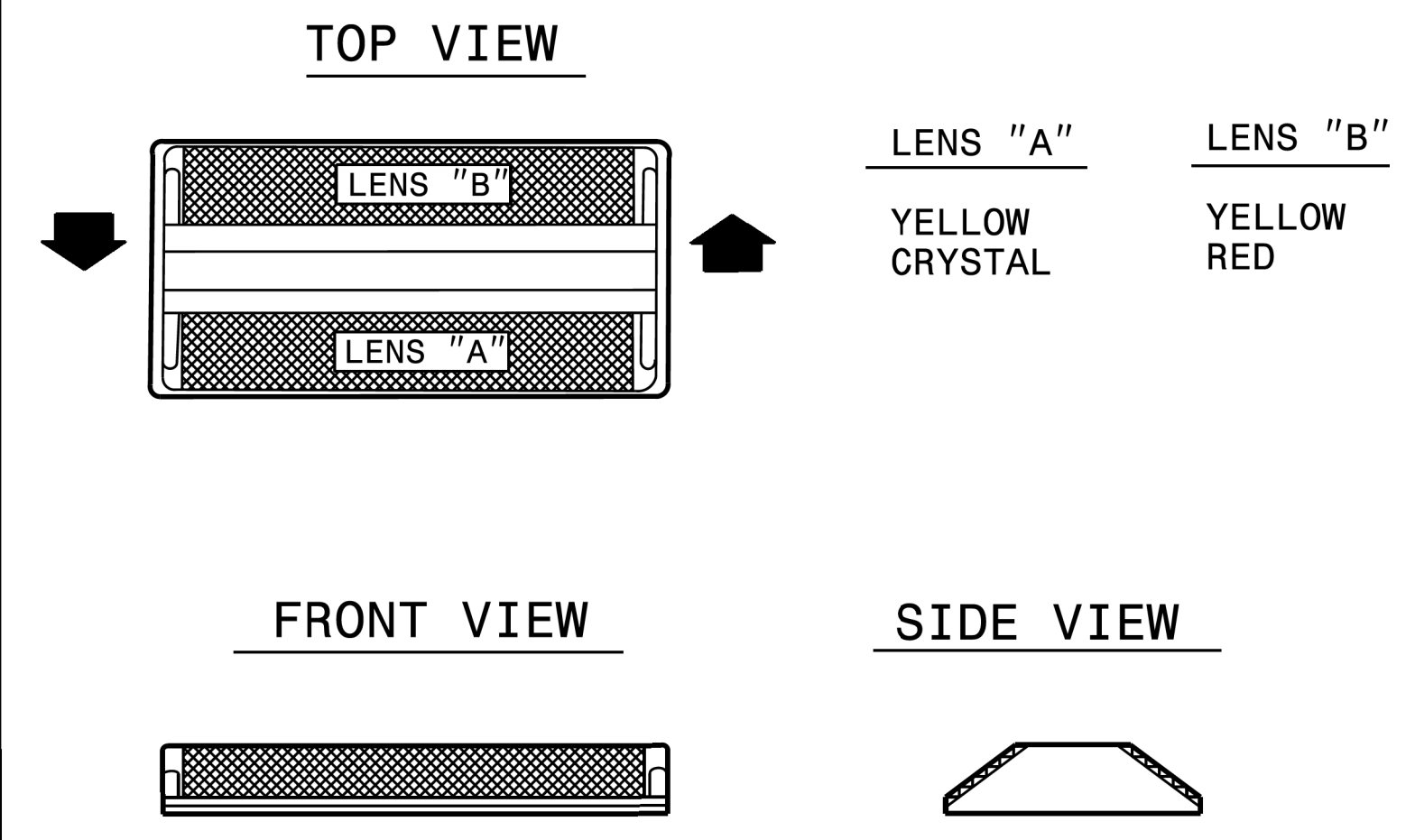

1-18
 STATE OF NORTH CAROLINA
 DEPT. OF TRANSPORTATION
 DIVISION OF HIGHWAYS
 RALEIGH, N.C.

ROADWAY STANDARD DRAWING FOR
RAISED PAVEMENT MARKERS
 SNOWPLOWABLE

- GENERAL NOTES:
- 1- USE A MINIMUM OF 1.44+/- SQ. INCH AREA FOR EACH REFLECTIVE LENS.
 - 2- SAWCUT GROOVES TO DIMENSIONS PROVIDED BY THE MANUFACTURER.
 - 3- CONTACT ALL LEVELING LUGS TO THE PAVEMENT SURFACE.
 - 4- REFLECTOR DIMENSIONS CAN VARY, BUT DESIGNED TO FIT IN THE CASTING AND PROVIDE THE REQUIRED REFLECTIVITY.

LEGEND

DIRECTION OF TRAFFIC FLOW

SHEET 1 OF 1
1253.01

RK&K
 P: (919) 878-9560
 8601 Six Forks Road, Forum 1, Suite 700
 Raleigh, North Carolina 27615-3960
 NC License No. F-0112

Engineers | Construction Managers | Planners | Scientists
 www.rkk.com

Responsive People | Creative Solutions

NCDOT STD. DETAIL

4/7/2026
 B-6051/PMP-1A.dgn

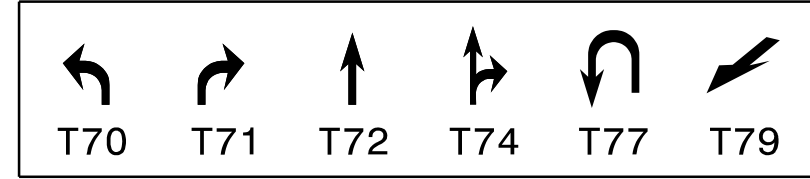

TIP NO.	SHEET NO.
B-6051/U-6143	PMP-3
APPROVED:	
DATE:	4/7/2026
SEAL	
DOCUMENT NOT CONSIDERED FINAL UNLESS ALL SIGNATURES COMPLETED	

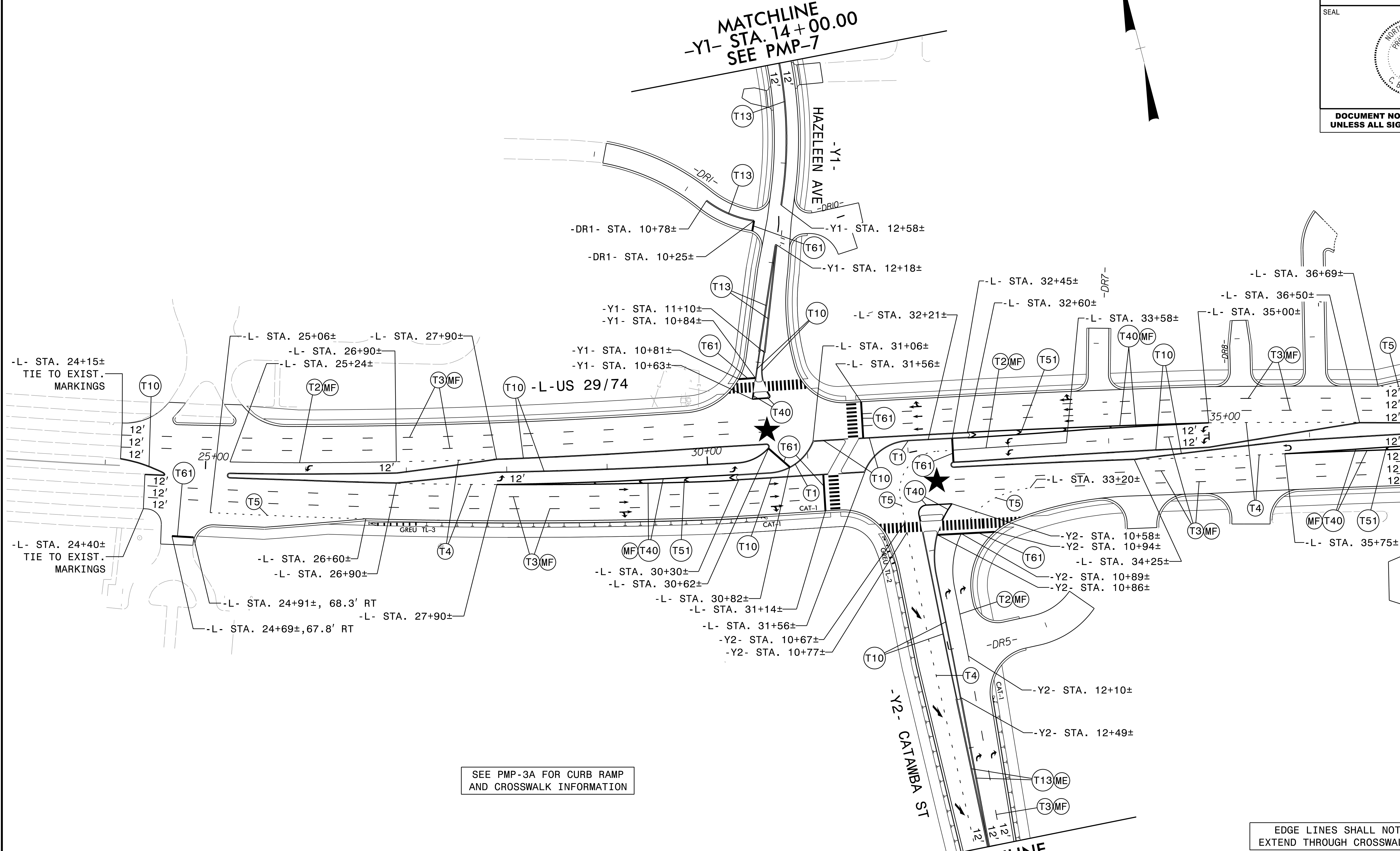

MATCHLINE -L- STA. 37 + 00.00 SEE PMP-4

SEE PMP-3A FOR CURB RAMP AND CROSSWALK INFORMATION

EDGE LINES SHALL NOT EXTEND THROUGH CROSSWALKS

★ SIGNALIZED INTERSECTION

PAVEMENT MARKING DETAIL

RK&K
 P: (919) 878-9560
 8601 Six Forks Road, Forum 1, Suite 700
 Raleigh, North Carolina 27615-3960
 NC License No. F-0112

Engineers | Construction Managers | Planners | Scientists
 www.rkk.com

Responsive People | Creative Solutions

4/7/2026
B-6051-PMP-F-SH03.dgn
C:\Users\jgibson

CURB RAMP DATA

1	-L-	STA. 24+98±	62.0'	RT	(TYPE 1 MODIFIED)
2	-L-	STA. 25+47±	56.9'	LT	(TYPE 1 MODIFIED)
3	-DR1-	STA. 10+21±	13.5'	RT	(TYPE 1 MODIFIED)
4	-DR1-	STA. 10+22±	13.7'	LT	(TYPE 1 MODIFIED)
5	-DR10-	STA. 10+23±	15.2'	LT	(TYPE 1 MODIFIED)
6	-DR10-	STA. 10+20±	12.9'	RT	(TYPE 1 MODIFIED)
7	-Y1-	STA. 10+70±	27.2'	LT	(TYPE 3 MODIFIED)
8	-Y1-	STA. 10+75±	2.6'	LT	(TYPE 7)
9	-Y1-	STA. 10+77±	6.9'	RT	(TYPE 7)
10	-Y1-	STA. 10+85±	47.8'	RT	(TYPE 3 MODIFIED)
11	-L-	STA. 31+46±	55.2'	LT	(STANDARD)
12	-L-	STA. 31+46±	16.5'	LT	(TYPE 7)
13	-L-	STA. 31+24±	16.3'	RT	(TYPE 7)
14	-L-	STA. 31+24±	55.0'	RT	(STANDARD)
15	-Y2-	STA. 10+69±	43.3'	RT	(STANDARD)
16	-Y2-	STA. 10+75±	2.0'	RT	(TYPE 7)
17	-Y2-	STA. 10+77±	15.3'	LT	(TYPE 7)
18	-Y2-	STA. 10+88±	88.7'	LT	(STANDARD)
19	-DR5-	STA. 10+45±	21.6'	LT	(TYPE 1 MODIFIED)
20	-DR5-	STA. 10+43±	31.4'	RT	(TYPE 1 MODIFIED)
21	-L-	STA. 33+80±	64.6'	LT	(TYPE 1 MODIFIED)
22	-L-	STA. 34+05±	64.7'	LT	(TYPE 1 MODIFIED)
23	-L-	STA. 35+20±	64.3'	LT	(TYPE 1 MODIFIED)
24	-L-	STA. 35+45±	63.7'	LT	(TYPE 1 MODIFIED)
25	-L-	STA. 35+95±	62.8'	LT	(TYPE 1 MODIFIED)
26	-L-	STA. 36+20±	62.3'	LT	(TYPE 1 MODIFIED)
27	-L-	STA. 34+08±	64.7'	RT	(TYPE 1 MODIFIED)
28	-L-	STA. 34+54±	64.6'	RT	(TYPE 1 MODIFIED)
29	-L-	STA. 35+14±	64.3'	RT	(TYPE 1 MODIFIED)
30	-L-	STA. 35+67±	63.3'	RT	(TYPE 1 MODIFIED)

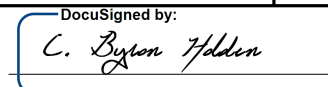
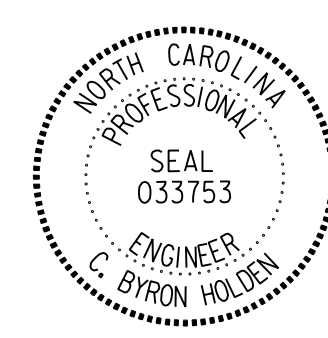
TIP NO.	B-6051/U-6143	SHEET NO.	PMP-3A
APPROVED:	 <small>SCS4055EAF0545F</small>		
DATE:	4/7/2026		
SEAL			
DOCUMENT NOT CONSIDERED FINAL UNLESS ALL SIGNATURES COMPLETED			

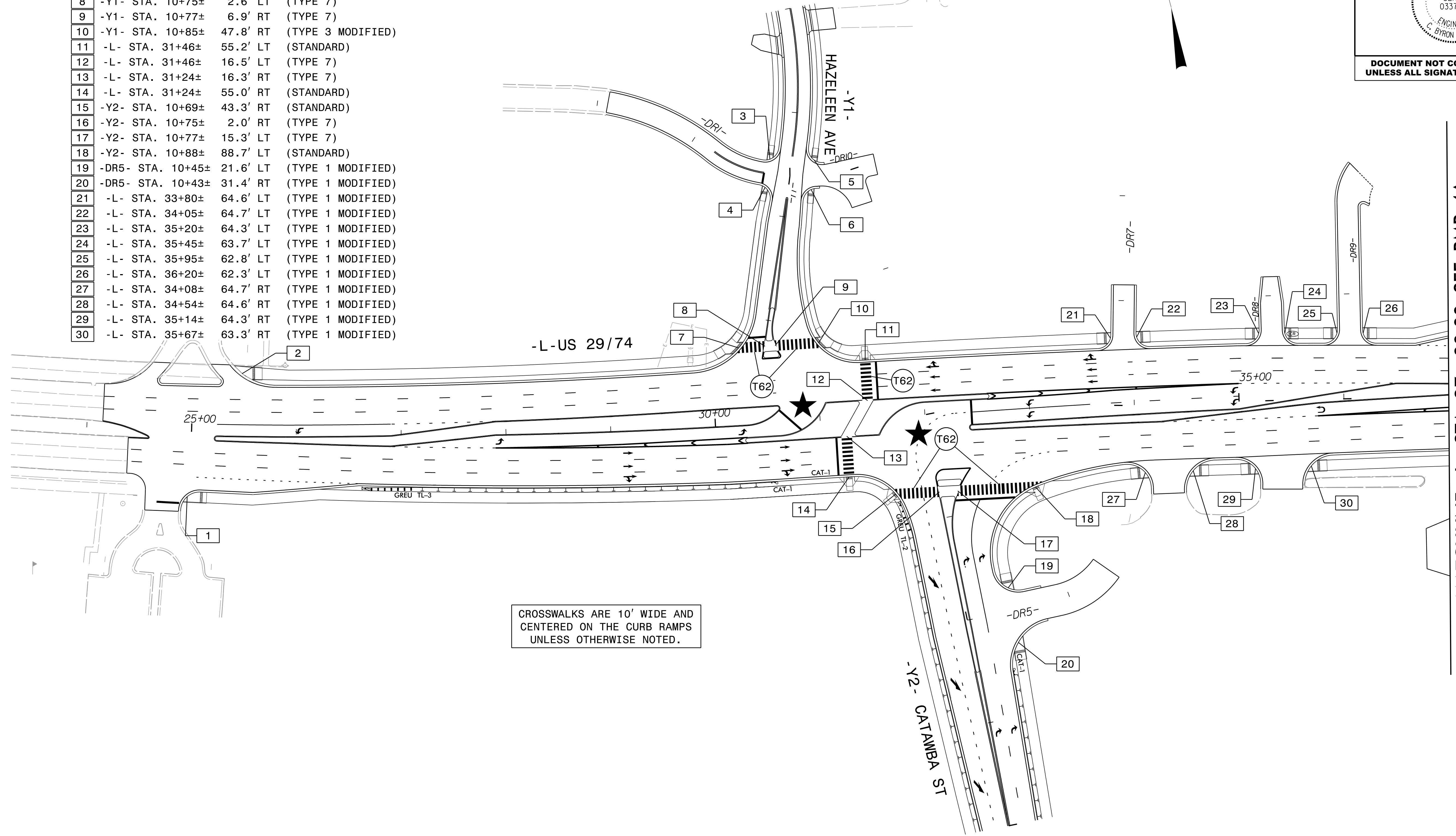

CROSSWALKS ARE 10' WIDE AND CENTERED ON THE CURB RAMPS UNLESS OTHERWISE NOTED.

MATCHLINE -L- STA. 37 + 00.00 SEE PMP-4A

★ SIGNALIZED INTERSECTION

CURB RAMPS & CROSSWALKS

RK&K
P: (919) 878-9560
8601 Six Forks Road, Forum 1, Suite 700
Raleigh, North Carolina 27615-3960
NC License No. F-0112

Engineers | Construction Managers | Planners | Scientists
www.rkk.com

Responsive People | Creative Solutions

4/7/2026
B-6051-PMP-F-PSH03A.dgn
C:\Users\...

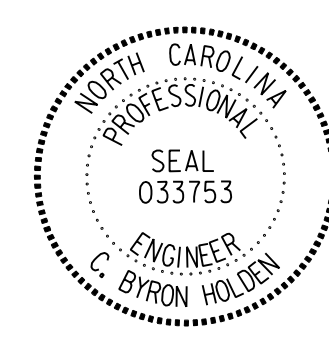
TIP NO.	SHEET NO.
B-6051/U-6143	PMP-4A
APPROVED:	DocuSigned by: <i>C. Byron Holden</i> SC54055EAF0545F
DATE:	4/7/2026
SEAL	
	
DOCUMENT NOT CONSIDERED FINAL UNLESS ALL SIGNATURES COMPLETED	

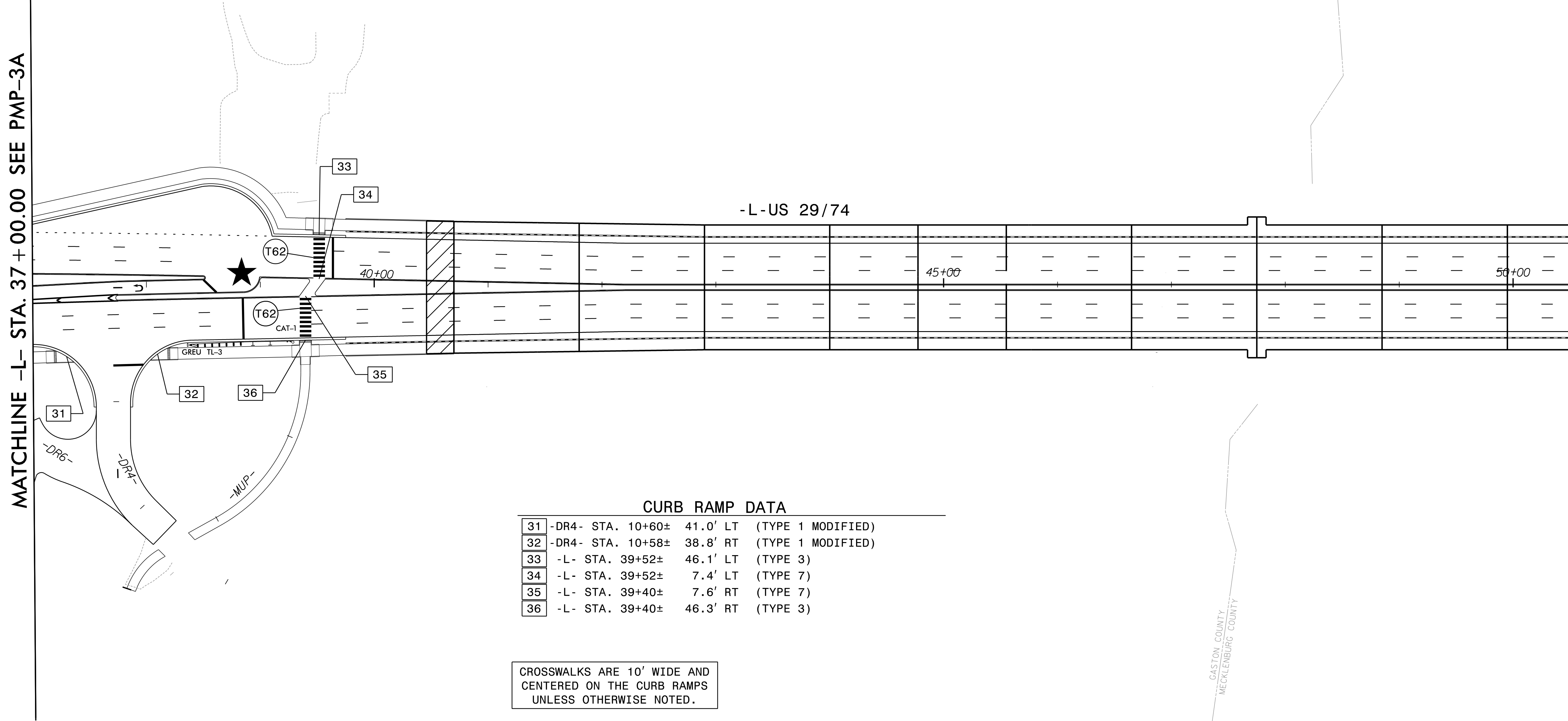

CURB RAMP DATA

31	-DR4-	STA. 10+60±	41.0'	LT	(TYPE 1 MODIFIED)
32	-DR4-	STA. 10+58±	38.8'	RT	(TYPE 1 MODIFIED)
33	-L-	STA. 39+52±	46.1'	LT	(TYPE 3)
34	-L-	STA. 39+52±	7.4'	LT	(TYPE 7)
35	-L-	STA. 39+40±	7.6'	RT	(TYPE 7)
36	-L-	STA. 39+40±	46.3'	RT	(TYPE 3)

CROSSWALKS ARE 10' WIDE AND CENTERED ON THE CURB RAMPS UNLESS OTHERWISE NOTED.

RK&K
P: (919) 878-9560
8601 Six Forks Road, Forum 1, Suite 700
Raleigh, North Carolina 27615-3960
NC License No. F-0112

Engineers | Construction Managers | Planners | Scientists
www.rkk.com

Responsive People | Creative Solutions

CURB RAMPS & CROSSWALKS

4/7/2026
B6051.PMP-F5H04A.dgn
03:54:18

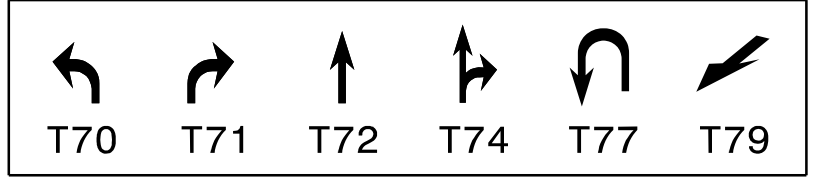

TIP NO.	SHEET NO.
B-6051/U-6143	PMP-5
APPROVED:	Designed by: <i>C. Byron Holden</i>
DATE:	4/7/2026
SEAL	

MATCHLINE -L- STA. 50 + 50.00 SEE PMP-4

MATCHLINE -L- STA. 63 + 00.00 SEE PMP-6

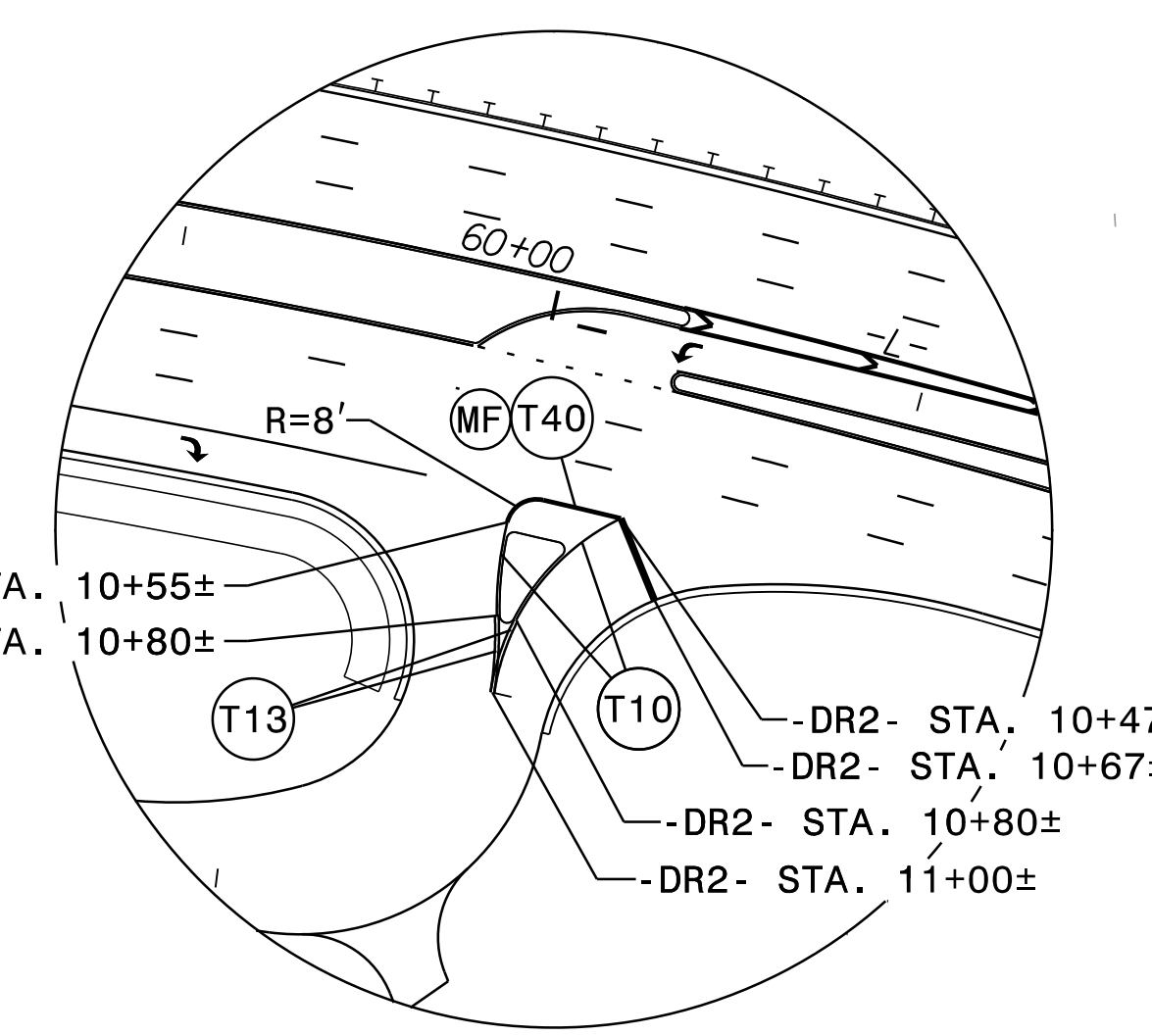
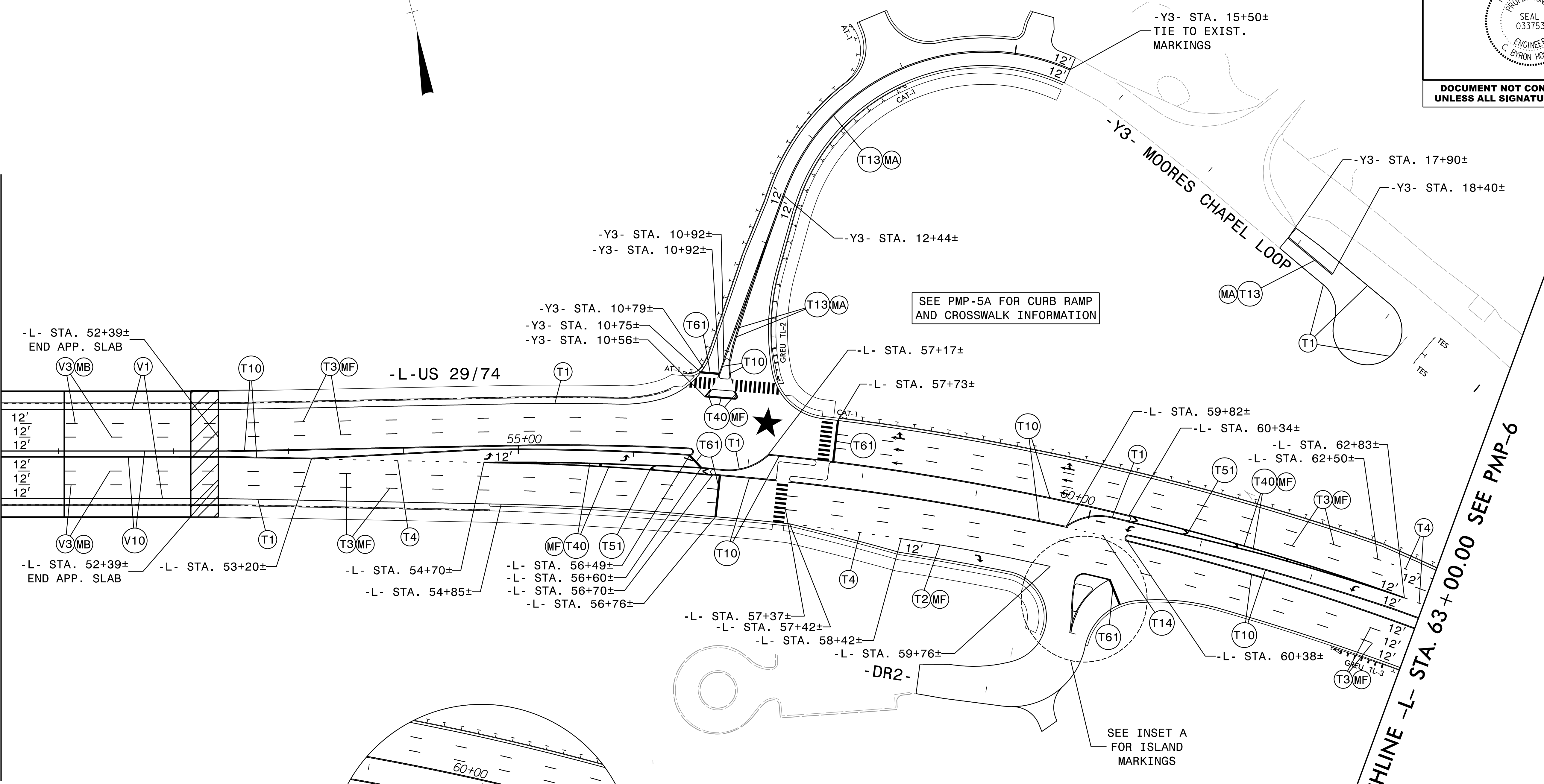

SEE PMP-5A FOR CURB RAMP AND CROSSWALK INFORMATION

SEE INSET A FOR ISLAND MARKINGS

EDGE LINES SHALL NOT EXTEND THROUGH CROSSWALKS

★ SIGNALIZED INTERSECTION

PAVEMENT MARKING DETAIL

RK&K
 P: (919) 878-9560
 8601 Six Forks Road, Forum 1, Suite 700
 Raleigh, North Carolina 27615-3960
 NC License No. F-0112

Engineers | Construction Managers | Planners | Scientists
 www.rkk.com

Responsive People | Creative Solutions

4/7/2026 8:05 AM PMP-F-PSH05.dgn

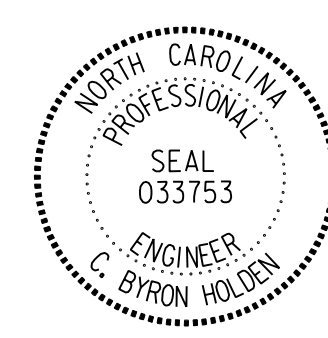
TIP NO.	SHEET NO.
B-6051/U-6143	PMP-5A
APPROVED:	DESIGNED BY: <i>C. Byron Holden</i>
DATE:	4/7/2026
SEAL	
	

DOCUMENT NOT CONSIDERED FINAL
UNLESS ALL SIGNATURES COMPLETED

MATCHLINE -L- STA. 50 + 50.00 SEE PMP-4A

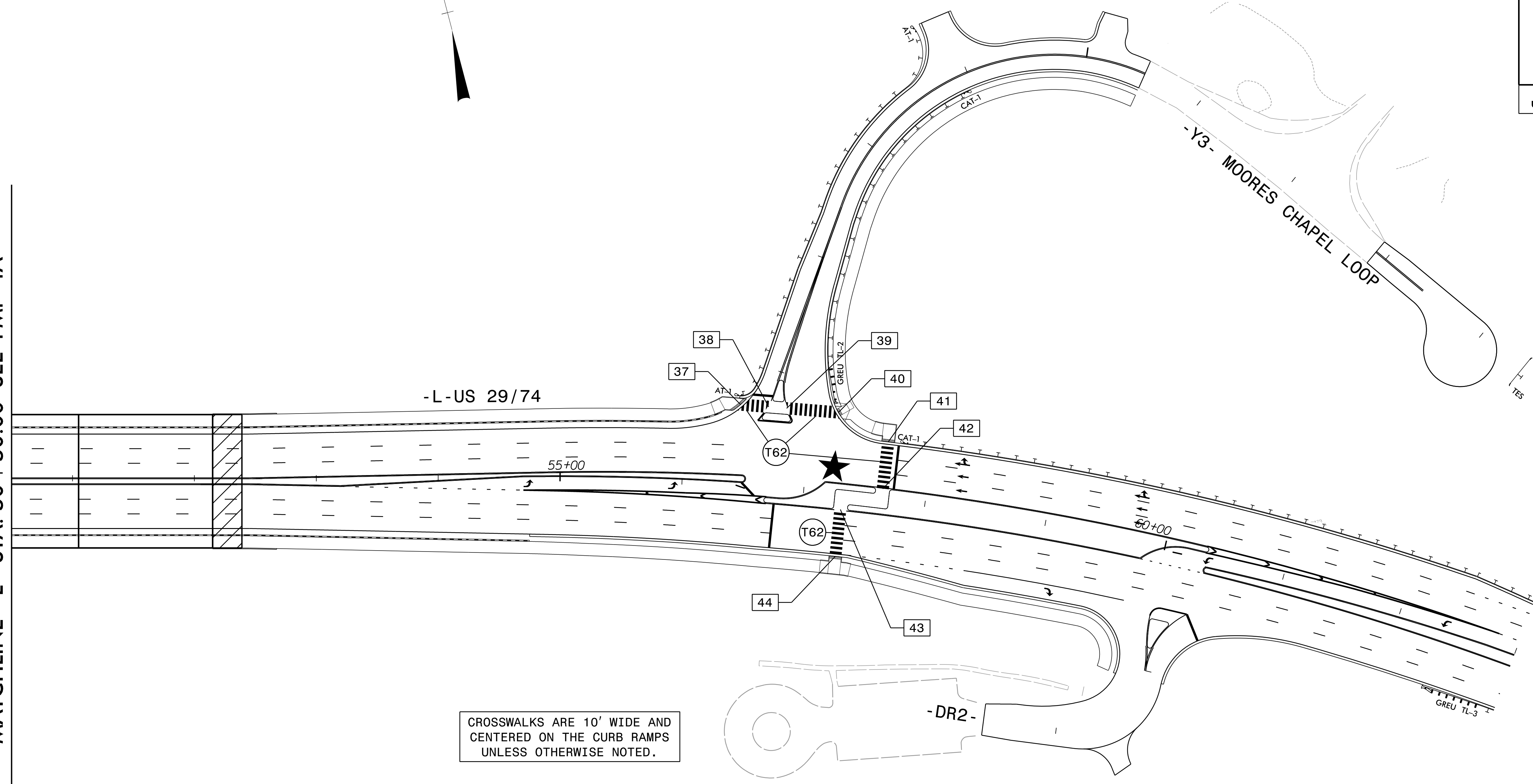

CROSSWALKS ARE 10' WIDE AND
CENTERED ON THE CURB RAMPS
UNLESS OTHERWISE NOTED.

CURB RAMP DATA

37	-Y3-	STA. 10+64±	25.5'	LT	(TYPE 3 MODIFIED)
38	-Y3-	STA. 10+70±	3.1'	LT	(TYPE 7)
39	-Y3-	STA. 10+73±	11.2'	RT	(TYPE 7)
40	-Y3-	STA. 10+84±	52.5'	RT	(STANDARD)
41	-L-	STA. 57+64±	49.1'	LT	(TYPE 3 MODIFIED)
42	-L-	STA. 57+64±	10.4'	LT	(TYPE 7)
43	-L-	STA. 57+32±	10.4'	RT	(TYPE 7)
44	-L-	STA. 57+32±	49.1'	RT	(TYPE 3)

★ SIGNALIZED INTERSECTION

CURB RAMPS & CROSSWALKS

RK&K
P: (919) 878-9560
8601 Six Forks Road, Forum 1, Suite 700
Raleigh, North Carolina 27615-3960
NC License No. F-0112

Engineers | Construction Managers | Planners | Scientists
www.rkk.com

Responsive People | Creative Solutions

4/7/2026
B-6051-U-6143-PMP-5A.dgn
C:\Users\...

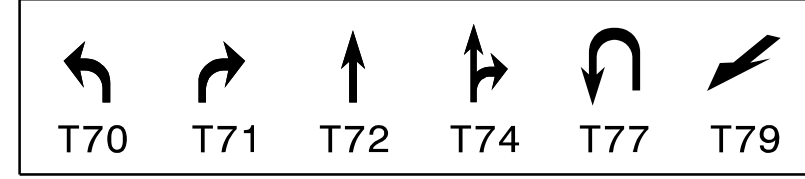

TIP NO. B-6051/U-6143	SHEET NO. PMP-6
APPROVED: <i>C. Byron Holden</i> <small>SCS04055EAF0545F</small>	
DATE: 4/7/2026	
DOCUMENT NOT CONSIDERED FINAL UNLESS ALL SIGNATURES COMPLETED	

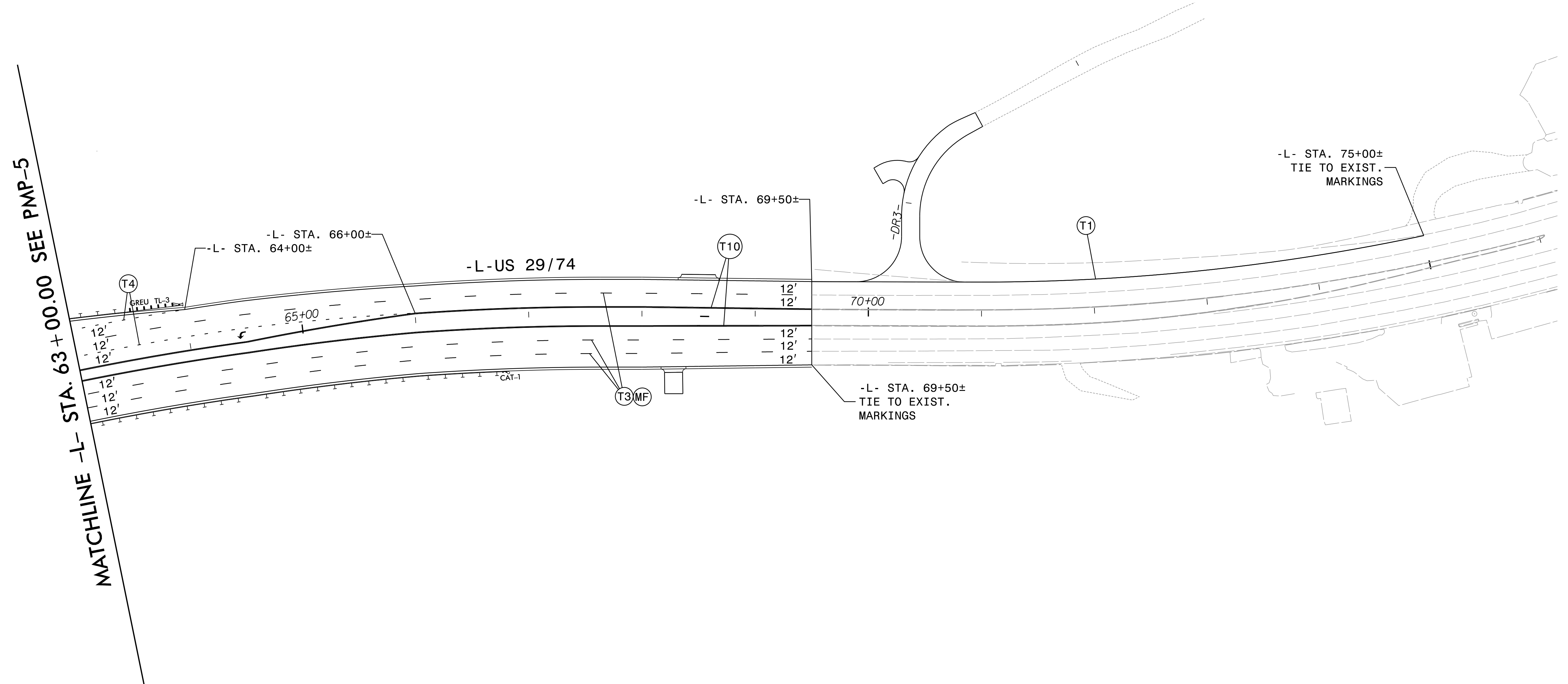

4/7/2026
 B6051PMP-FSH06.dgn
 C:\Users\...

RK&K
 P: (919) 878-9560
 8601 Six Forks Road, Forum 1, Suite 700
 Raleigh, North Carolina 27615-3960
 NC License No. F-0112

Engineers | Construction Managers | Planners | Scientists
 www.rkk.com

Responsive People | Creative Solutions

PAVEMENT MARKING DETAIL

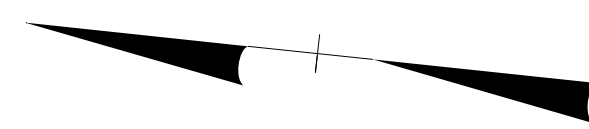
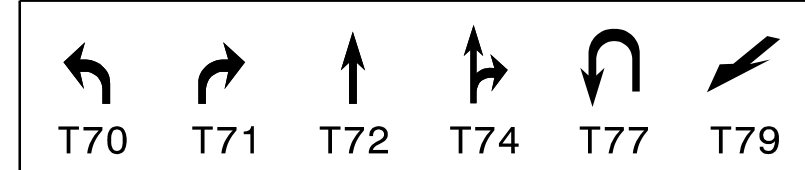

TIP NO. B-6051/U-6143	SHEET NO. PMP-7
APPROVED: <i>C. Byron Holden</i> <small>SCS04055EAF0545F</small>	
DATE: 4/7/2026	
SEAL	
DOCUMENT NOT CONSIDERED FINAL UNLESS ALL SIGNATURES COMPLETED	

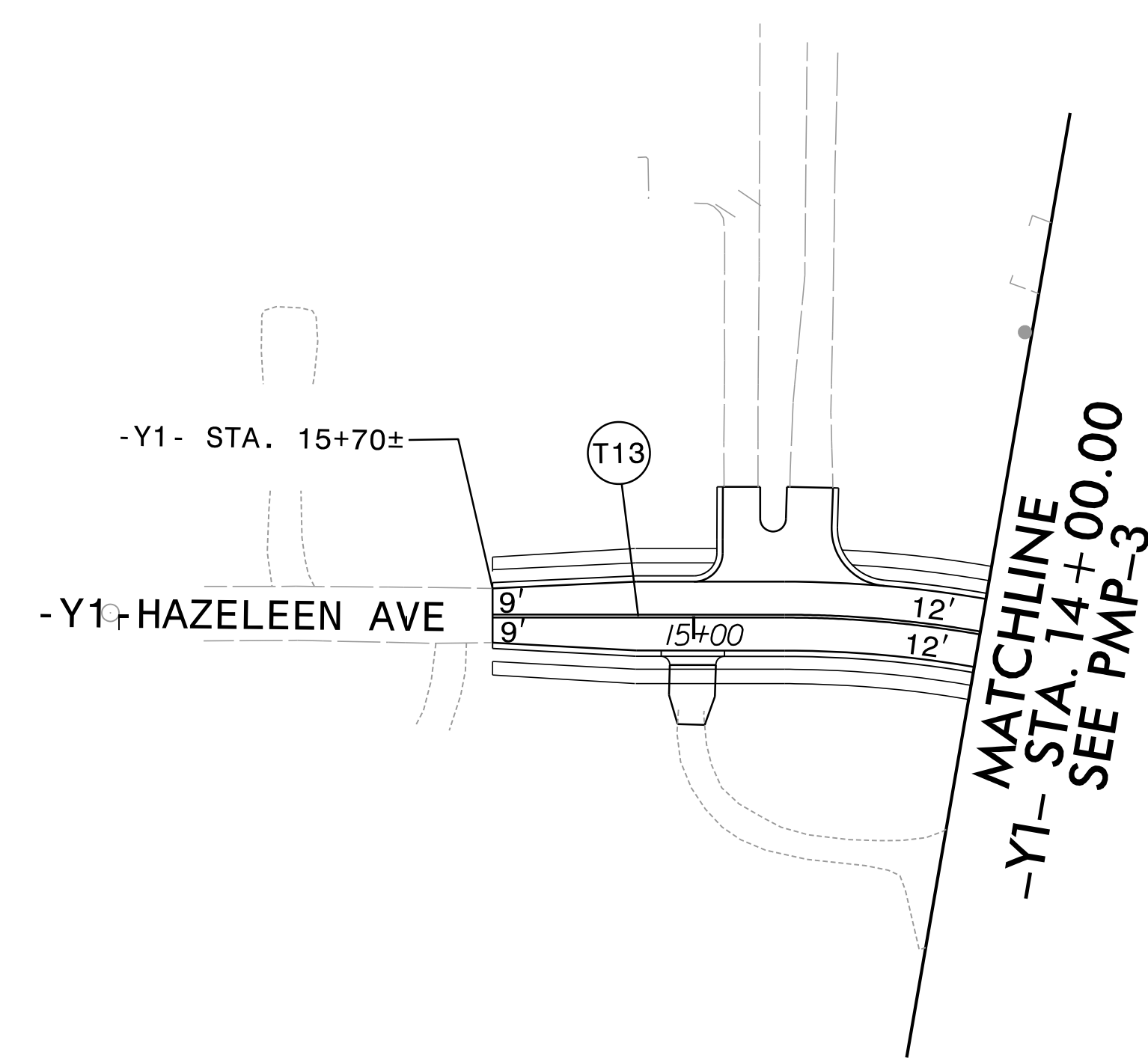

SEE PMP-7A FOR CURB
RAMP INFORMATION

PAVEMENT MARKING DETAIL

4/7/2026
B-6051/U-6143-PMP-7.dgn
C:\Users\jg\OneDrive\Documents\Projects\B-6051/U-6143-PMP-7.dgn

RK&K
 P: (919) 878-9560
 8601 Six Forks Road, Forum 1, Suite 700
 Raleigh, North Carolina 27615-3960
 NC License No. F-0112

Engineers | Construction Managers | Planners | Scientists
 www.rkk.com

Responsive People | Creative Solutions

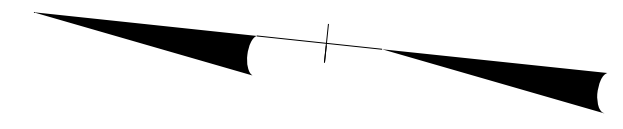
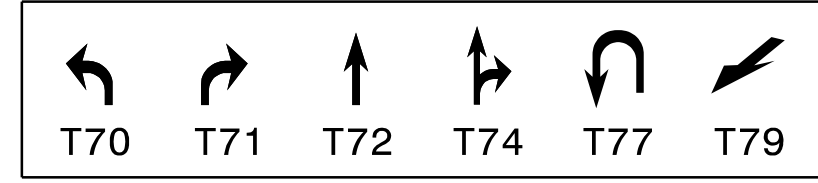

TIP NO. B-6051/U-6143	SHEET NO. PMP-7A
APPROVED: <i>C. Byron Holden</i> <small>SC54285EAF0545F...</small>	
DATE: 4/7/2026	
DOCUMENT NOT CONSIDERED FINAL UNLESS ALL SIGNATURES COMPLETED	

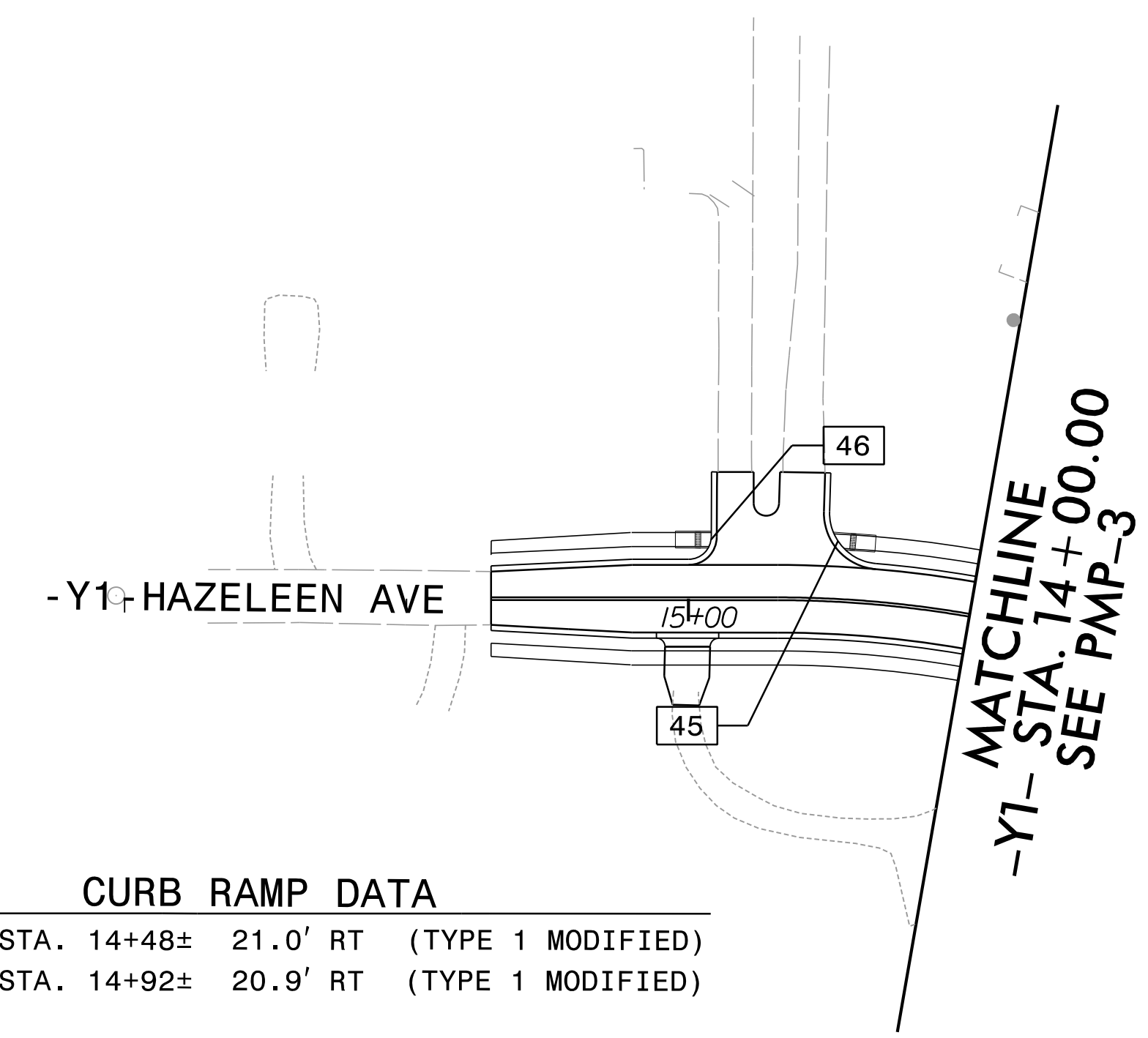

CURB RAMP DATA

45	-Y1- STA. 14+48±	21.0' RT	(TYPE 1 MODIFIED)
46	-Y1- STA. 14+92±	20.9' RT	(TYPE 1 MODIFIED)

4/7/2026
 B6051.PMP_P5H07A.dgn
 User:rs

RK&K
 P: (919) 878-9560
 8601 Six Forks Road, Forum 1, Suite 700
 Raleigh, North Carolina 27615-3960
 NC License No. F-0112

Engineers | Construction Managers | Planners | Scientists
 www.rkk.com

Responsive People | Creative Solutions

CURB RAMPS & CROSSWALKS

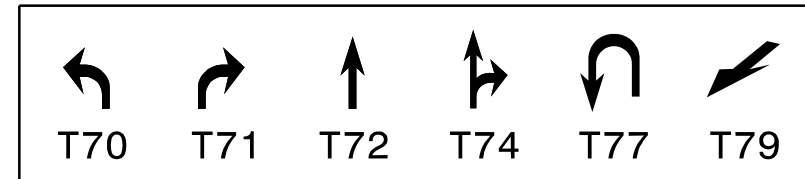

TIP NO.	SHEET NO.
B-6051/U-6143	PMP-8
APPROVED: <i>C. Byron Holden</i>	
DATE: 4/7/2026	
DOCUMENT NOT CONSIDERED FINAL UNLESS ALL SIGNATURES COMPLETED	

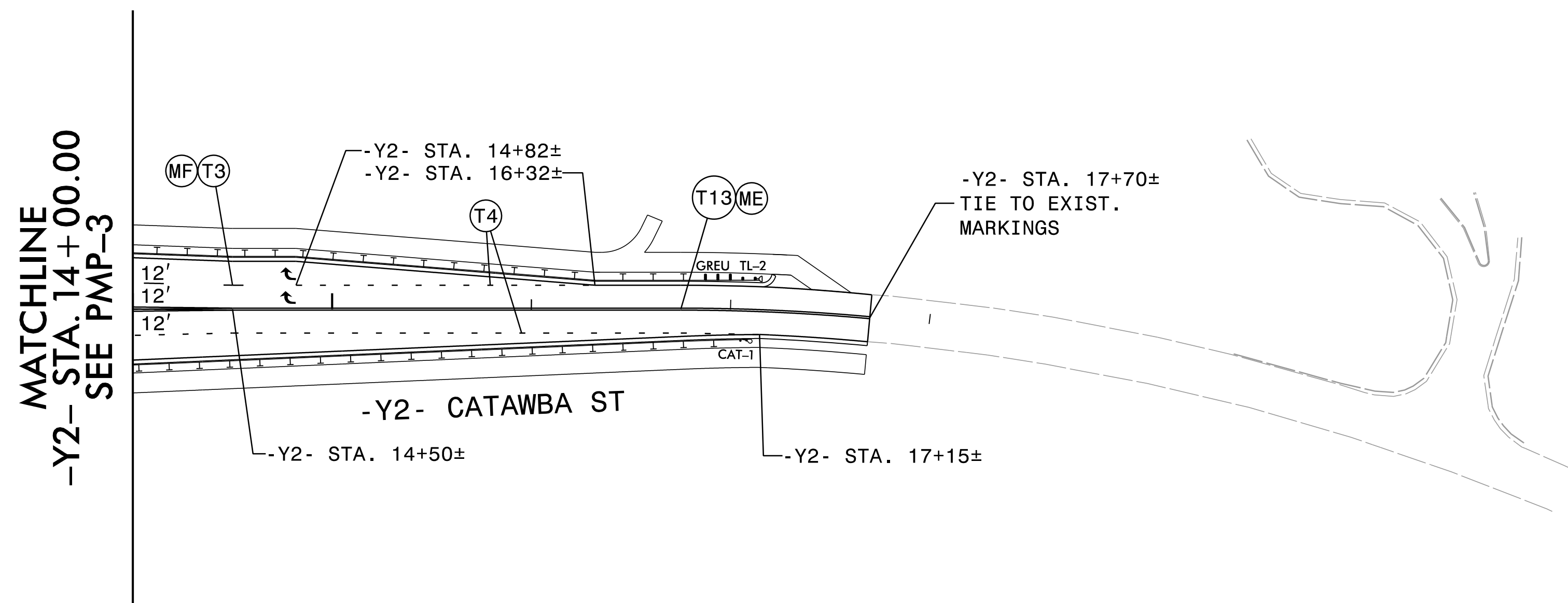
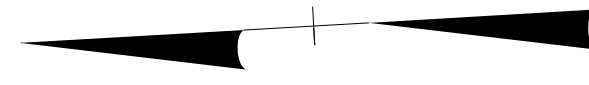

4/7/2026
 B6051.PMP-F-PSH08.dgn
 C:\Users\...

RK&K
 P: (919) 878-9560
 8601 Six Forks Road, Forum 1, Suite 700
 Raleigh, North Carolina 27615-3960
 NC License No. F-0112

Engineers | Construction Managers | Planners | Scientists
 www.rkk.com

Responsive People | Creative Solutions

PAVEMENT MARKING DETAIL