

STATE OF NORTH CAROLINA
DIVISION OF HIGHWAYS

TRANSPORTATION MANAGEMENT PLAN
FORSYTH COUNTY

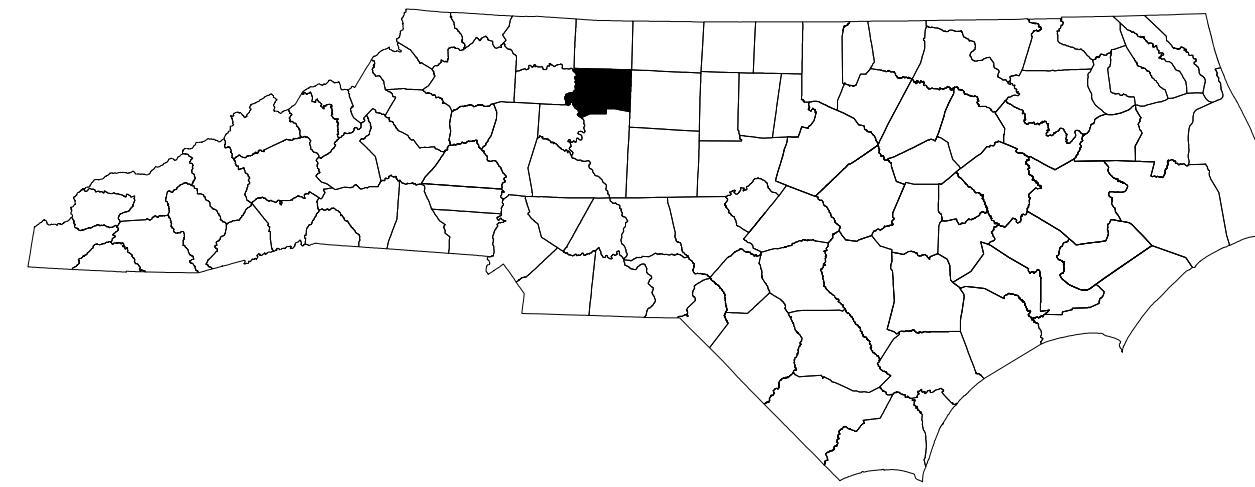

REPLACE BRIDGE 330289 ON SR 4000 (UNIVERSITY PKWY) OVER US52



SHEET NO.	TITLE
TMP-1	TITLE SHEET, VICINITY MAP, AND INDEX OF SHEETS
TMP-1A	LIST OF APPLICABLE ROADWAY STANDARD DRAWINGS, AND LEGEND
TMP-1B	PORTABLE CONCRETE BARRIER AT TEMPORARY SHORING LOCATIONS
TMP-1C	TEMPORARY SHORING DATA
TMP-2	GENERAL NOTES
TMP-2A	GENERAL NOTES AND TMP MANAGEMENT STRATEGIES
TMP-2B	TMP PHASING
TMP-2C	DETOUR - SB FULL CLOSURE
TMP-2D	DETOUR - NB FULL CLOSURE
TMP-2E	DETOUR - SB RAMP CLOSURES (30 DAY ICT)
TMP-2F	DETOUR - NB RAMP CLOSURES (30 DAY ICT)
TMP-2G	DETOUR - SIGN DESIGN
TMP-3.1	TMP PHASE 1, STEP 1
TMP-3.2	TMP PHASE 1, STEP 2 - US 52 DETAILS
TMP-3.3	TMP PHASE 1, STEP 3 (1)
TMP-3.3A	TMP PHASE 1, STEP 3 (1) XS
TMP-3.4	TMP PHASE 1, STEP 3 (2)
TMP-3.5	TMP PHASE 1, STEP 5 (30 DAY ICT)
TMP-3.6	TMP PHASE 1, STEP 6 (30 DAY ICT)
TMP-4.1	TMP PHASE 2, STEP 1 (1)
TMP-4.2	TMP PHASE 2, STEP 1 (2)
TMP-5.1	STATIC WZ SPEED REDUCTION (UNIVERSITY PKWY)
TMP-5.2	VARIABLE WZ SPEED REDUCTION (US-52)

SHEET NO.
TMP-1

BR-0168

TIP PROJECT:

2/10/2026
pw:/ncdot-pw-bentley.com/ncdot-pw-01/Documents/Division_09/BR-0168/Work Zone Traffic Control/BR-0168-TC-TMP-01-Title Page
User: jdbeaver1



PLANS PREPARED BY:

Ken Thornewell, Jr., PE

Justin Beaver, PE

NCDOT CONTACTS:

Joel Perlin
PROJECT MANAGER

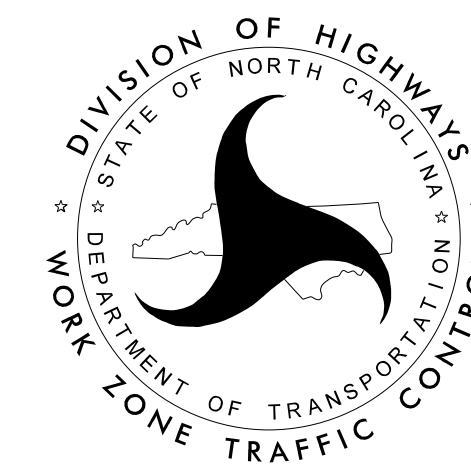

DOCUMENT NOT CONSIDERED FINAL
UNLESS ALL SIGNATURES COMPLETED

APPROVED: *Kenneth C. Thornewell, Jr., P.E.*
DATE: 03/06/2026

SEAL

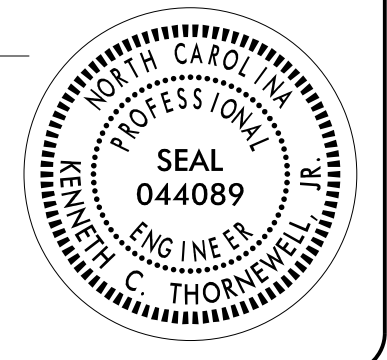

ROADWAY STANDARD DRAWINGS

THE FOLLOWING ROADWAY STANDARDS AS SHOWN IN "ROADWAY STANDARD DRAWINGS" - N.C. DEPARTMENT OF TRANSPORTATION - RALEIGH, N.C., DATED JANUARY 2024 ARE APPLICABLE TO THIS PROJECT AND BY REFERENCE HEREBY ARE CONSIDERED A PART OF THESE PLANS:

STD. NO.	TITLE
1101.01	WORK ZONE ADVANCE WARNING SIGNS
1101.02	TEMPORARY LANE CLOSURES
1101.03	TEMPORARY ROAD CLOSURES
1101.04	TEMPORARY SHOULDER CLOSURES
1101.05	WORK ZONE VEHICLE ACCESSES
1101.06	WARNING SIGNS FOR BLASTING ZONES
1101.11	TRAFFIC CONTROL DESIGN TABLES
1110.01	STATIONARY WORK ZONE SIGNS
1110.02	PORTABLE WORK ZONE SIGNS
1115.01	FLASHING ARROW BOARDS
1130.01	DRUM
1135.01	CONES
1145.01	BARRICADES
1150.01	FLAGGING DEVICES
1160.01	TEMPORARY CRASH CUSHION
1165.01	WORK VEHICLE LIGHTING SYSTEMS AND TMA DELINEATION
1170.01	POSITIVE PROTECTION
1180.01	SKINNY-DRUM
1205.01	PAVEMENT MARKINGS - LINE TYPES AND OFFSETS
1205.02	PAVEMENT MARKINGS - TWO-LANE AND MULTI-LANE ROADWAYS
1205.03	PAVEMENT MARKINGS - EXITS AND ENTRANCE RAMP
1205.04	PAVEMENT MARKINGS - INTERSECTIONS
1205.05	PAVEMENT MARKINGS - TURN LANES
1205.06	PAVEMENT MARKINGS - LANE DROPS
1205.07	PAVEMENT MARKINGS - PEDESTRIAN CROSSWALKS
1205.08	PAVEMENT MARKINGS - SYMBOLS AND WORD MESSAGES
1205.09	PAVEMENT MARKINGS - PAINTED ISLANDS
1205.10	PAVEMENT MARKINGS - SCHOOL AREAS
1205.11	PAVEMENT MARKINGS - RAILROAD CROSSINGS
1205.12	PAVEMENT MARKINGS - BRIDGES
1205.13	PAVEMENT MARKINGS - LANE REDUCTIONS
1205.14	PAVEMENT MARKINGS - ROUNDABOUTS
1205.15	PAVEMENT MARKINGS - REDUCED CONFLICT INTERSECTIONS
1205.16	BICYCLE FACILITIES
1205.17	PAVEMENT MARKINGS - SIDE-BY-SIDE/ADJACENT ON/OFF RAMP
1250.01	RAISED PAVEMENT MARKERS - INSTALLATION SPACING
1251.01	RAISED PAVEMENT MARKERS - PERMANENT AND TEMPORARY
1261.01	GUARDRAIL AND BARRIER DELINEATORS - INSTALLATION SPACING
1261.02	GUARDRAIL AND BARRIER DELINEATORS - TYPES AND MOUNTING
1262.01	GUARDRAIL END DELINEATION
1264.01	OBJECT MARKERS - TYPES
1264.02	OBJECT MARKERS - INSTALLATION
1266.01	RAISED PAVEMENT MARKERS - TUBULAR MARKERS
1267.01	FLEXIBLE DELINEATORS - INSTALLATION
1267.02	FLEXIBLE DELINEATORS - SPACING TABLES
1267.03	FLEXIBLE DELINEATORS - INTERCHANGE PLACEMENT

LEGEND

GENERAL

- DIRECTION OF TRAFFIC FLOW
- DIRECTION OF PEDESTRIAN TRAFFIC FLOW
- EXIST. PVMT.
- NORTH ARROW
- PROPOSED PVMT.
- TEMP. SHORING (LOCATION PURPOSES ONLY)

- WORK AREA
- REMOVAL
- TEMPORARY PAVEMENT

PAVEMENT MARKINGS

- EXISTING LINES
- TEMPORARY LINES

TRAFFIC CONTROL DEVICES

- BARRICADE (TYPE III)
- CONE
- DRUM SKINNY DRUM TUBULAR MARKER
- TEMPORARY CRASH CUSHION
- FLASHING ARROW BOARD
- FLAGGER
- LAW ENFORCEMENT
- TRUCK MOUNTED ATTENUATOR (TMA)
- CHANGEABLE MESSAGE SIGN

TEMPORARY SIGNING

- PORTABLE SIGN
- STATIONARY SIGN
- STATIONARY OR PORTABLE SIGN

PAVEMENT MARKERS

- CRYSTAL/CRYSTAL
- CRYSTAL/RED
- YELLOW/YELLOW

PAVEMENT MARKING SYMBOLS

- PAVEMENT MARKING SYMBOLS

TEMPORARY PAVEMENT MARKING

PAINT

- | | | |
|-------------------------------|-------------------------------|--------------------------------|
| P1 White Edgeline (4") | P10 Yellow Edgeline (4") | P42 Yellow Diagonal (8") |
| P2 White Solid Lane Line (4") | P11 Yellow Single Center (4") | P43 White Solid Lane Line (8") |
| P3 10' White Skip | P13 Yellow Double Center (4") | P44 3'-9' White Miniskip (8") |
| P4 3'-9' White Miniskip (4") | P40 White Goreline (8") | P61 White Stopbar (24") |
| P5 2'-6' White Miniskip (4") | P41 White Diagonal (8") | P103 24" Yield Line Triangle |

2/11/2026
pw:/ncdot-pw.bentley.com:ncdot-pw-01/Documents/Division_09/BR-0168/Work Zone Traffic Control/BR-0168-TC-TMP-01A-Legend
User: jbeaver1

APPROVED: DATE: 03/06/2026 SEAL			<h2>ROADWAY STANDARD DRAWINGS & LEGEND</h2>
DOCUMENT NOT CONSIDERED FINAL UNLESS ALL SIGNATURES COMPLETED			

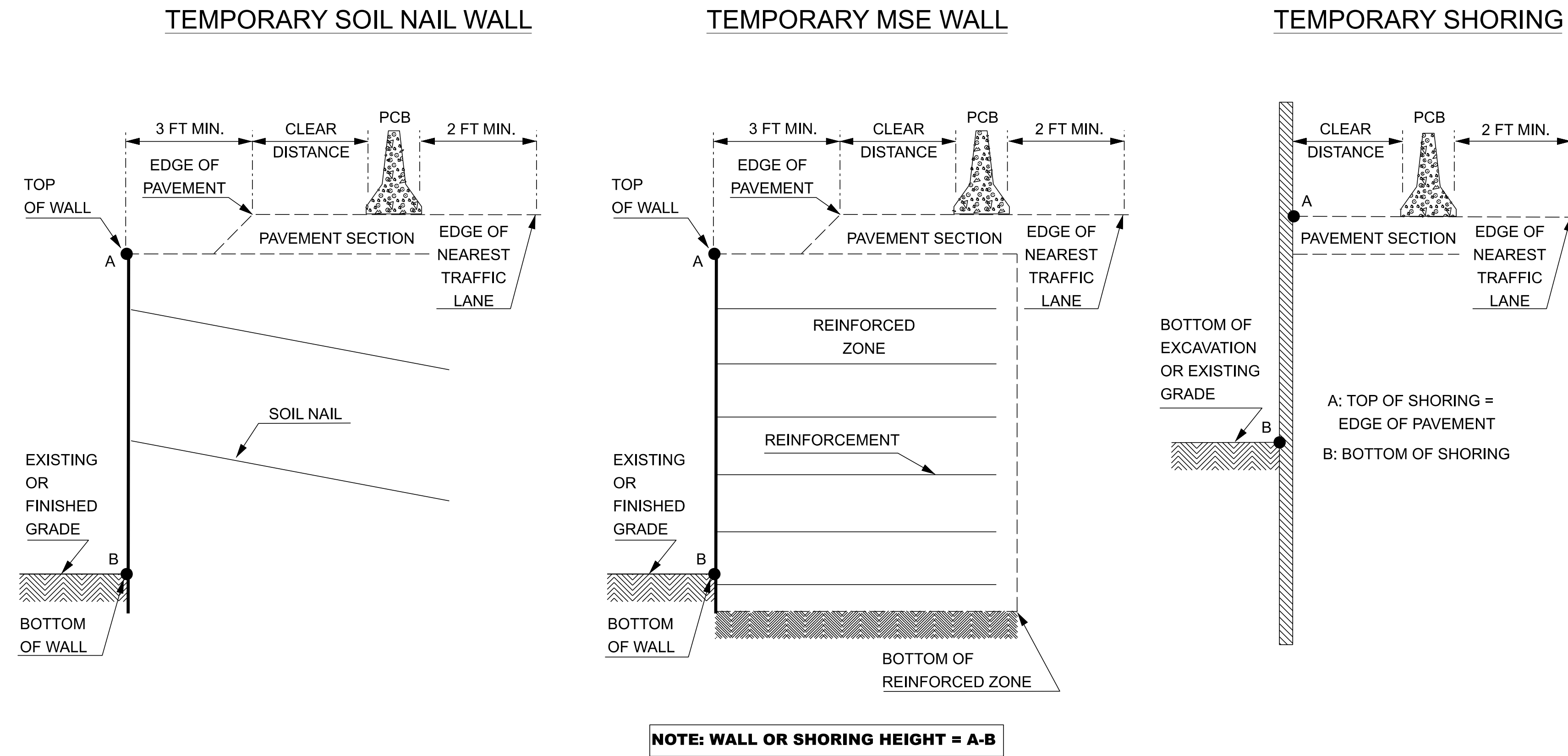

FIGURE A

NOTES

- 1- REFER TO THE TRAFFIC CONTROL PLANS FOR TEMPORARY SHORING LOCATIONS AND NOTES.
- 2- REFER TO THE "TEMPORARY SHORING" STANDARD PROVISION FOR INFORMATION ABOUT TEMPORARY SHORING AND PORTABLE CONCRETE BARRIER (PCB).
- 3- PCB IS REQUIRED IF TEMPORARY SHORING/WALL IS LOCATED WITHIN THE CLEAR ZONE IN ACCORDANCE WITH THE AASHTO ROADSIDE DESIGN GUIDE. DO NOT PLACE BARRIER DIRECTLY ON ANY SURFACE OTHER THAN ASPHALT OR CONCRETE. (CONTACT NCDOT PAVEMENT MANAGEMENT FOR APPLICABLE PAVEMENT DESIGN).
- 4- BASED ON THE CLEAR DISTANCE, OFFSET, DESIGN SPEED AND PAVEMENT TYPE, CHOOSE AN UNANCHORED OR ANCHORED PCB FROM THE TABLE SHOWN IN FIGURE B. CLEAR DISTANCE IS DEFINED AS SHOWN IN FIGURE A AND OFFSET IS DEFINED AS SHOWN IN FIGURE B.
- 5- AT THE CONTRACTOR'S OPTION OR IF THE MINIMUM REQUIRED CLEAR DISTANCE IS NOT AVAILABLE, SET PCB NEXT TO AND UP AGAINST THE TRAFFIC SIDE OF THE TEMPORARY SHORING/WALLS EXCEPT FOR BARRIER ABOVE TEMPORARY WALLS. PCB WITH THE MINIMUM REQUIRED CLEAR DISTANCE IS REQUIRED ABOVE TEMPORARY WALLS.
- 6- USE NCDOT PORTABLE CONCRETE BARRIER (PCB) IN ACCORDANCE WITH ROADWAY STANDARD DRAWING NO. 1170.01 AND SECTION 1170 OF THE STANDARD SPECIFICATIONS.
- 7- SET PCB WITH A MINIMUM HORIZONTAL DISTANCE OF 2 FT BETWEEN THE FRONT FACE OF THE BARRIER AND THE EDGE OF THE NEAREST TRAFFIC LANE AS SHOWN IN FIGURE A UNLESS OTHERWISE SHOWN IN THE PLANS OR APPROVED BY THE ENGINEER.
- 8- FOR PCB ABOVE AND BEHIND TEMPORARY WALLS, PROVIDE A MINIMUM DISTANCE OF 3 FT BETWEEN THE EDGE OF PAVEMENT AND THE WALL FACE AS SHOWN IN FIGURE A. IF THIS MINIMUM REQUIRED DISTANCE IS NOT AVAILABLE, CONTACT THE ENGINEER.
- 9- TABLE SHOWN IN FIGURE B IS BASED ON NCDOT RESEARCH PROJECT NO. 2005-010 WITH VEHICLE TYPE USED FOR NCHRP 350 CRASH TESTS.

MINIMUM REQUIRED CLEAR DISTANCE, inches

Barrier Type	Pavement Type	Offset * ft	Design Speed, mph							
			<30	31-40	41-50	51-60	61-70	71-80		
Unanchored PCB	Asphalt	<8	24	26	29	32	36	40		
		8-14	26	28	31	35	38	42		
		14-20	27	29	34	36	39	43		
		20-26	28	31	35	38	40	44		
		26-32	29	32	36	39	42	45		
		32-38	30	34	38	41	43	46		
		38-44	31	34	41	43	45	48		
	Concrete	44-50	31	35	41	43	46	49		
		50-56	32	36	42	44	47	50		
		>56	32	36	42	45	47	51		
		<8	17	18	21	22	25	26		
		8-14	19	20	23	25	26	29		
		14-20	22	22	24	26	28	31		
		20-26	23	24	26	27	30	34		
Anchored PCB	Asphalt	26-32	24	25	27	28	32	35		
		32-38	24	26	27	30	33	36		
		38-44	25	26	28	30	34	37		
		44-50	26	26	28	32	35	37		
		50-56	26	26	28	32	35	38		
		>56	26	27	29	32	36	38		
		Anchored PCB	Concrete (including bridge approach slabs)	All Offsets	24 for All Design Speeds					
				All Offsets	12 for All Design Speeds					

* See Figure Below

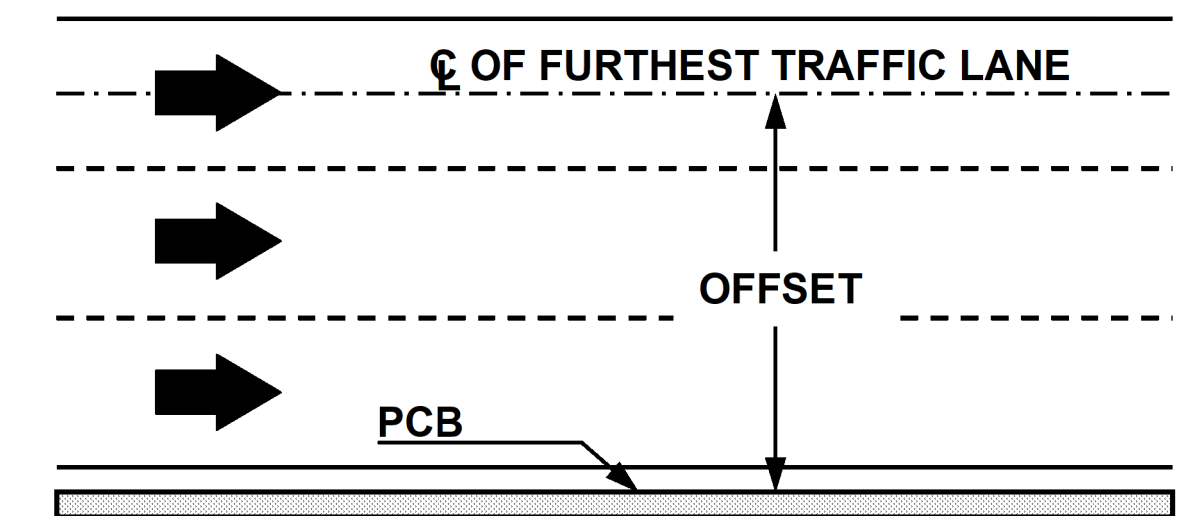
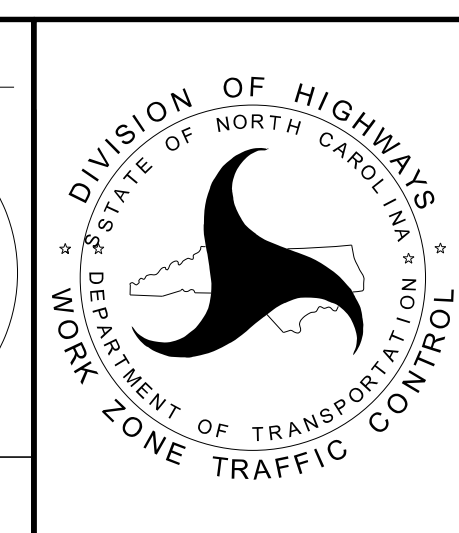

FIGURE B

APPROVED: *Kenneth C. Hornswell Jr., P.E.*
 DATE: 03/06/2026
 SEAL



PORTABLE CONCRETE BARRIER
 AT
 TEMPORARY SHORING LOCATIONS

DOCUMENT NOT CONSIDERED FINAL
 UNLESS ALL SIGNATURES COMPLETED

Shoring Location No. 1 and 2

FOR TEMPORARY SHORING AND POSITIVE PROTECTION FOR TEMPORARY SHORING, SEE PLANS AND TEMPORARY SHORING PROVISION.
 TEMPORARY SHORING LOCATION RANGES:
 LOCATION NO. 1 FROM STATION -L- 19+02, 6' RT TO -L- 19+80, 6' RT
 LOCATION NO. 2 FROM STATION -L- 21+45, 6' RT TO -L- 22+99, 6' RT

BEFORE BEGINNING TEMPORARY SHORING DESIGN OR CONSTRUCTION, SURVEY EXISTING GROUND ELEVATIONS IN THE VICINITY OF SHORING LOCATIONS TO DETERMINE ACTUAL SHORING HEIGHTS.

DESIGN TEMPORARY SHORING LOCATION NOS. 1 AND NO. 2, FOR THE FOLLOWING ASSUMED SOIL PARAMETERS AND GROUNDWATER ELEVATION:
 UNIT WEIGHT (γ) = 120 PCF
 FRICTION ANGLE (ϕ) = 30 DEGREES
 COHESION (c) = 0 PSF
 GROUNDWATER ELEVATION = N/A

LIMITED SUBSURFACE INFORMATION IS AVAILABLE IN THE VICINITY OF TEMPORARY SHORING LOCATION NOS. 1 AND NO. 2. THE INFORMATION PROVIDED FOR TEMPORARY SHORING DESIGN WAS ASSUMED AND MAY NOT BE APPLICABLE TO THE ACTUAL SITE CONDITIONS ENCOUNTERED DURING CONSTRUCTION.

IT MAY BE PREFERRED TO USE A TEMPORARY SOIL NAIL WALL FOR TEMPORARY SHORING LOCATION NOS. 1 AND NO. 2. FOR TEMPORARY SOIL NAIL WALLS, SEE TEMPORARY SOIL NAIL WALLS PROVISION.

Shoring Location No. 3 and 4

FOR TEMPORARY SHORING AND POSITIVE PROTECTION FOR TEMPORARY SHORING, SEE PLANS AND TEMPORARY SHORING PROVISION
 TEMPORARY SHORING LOCATION RANGES:
 LOCATION NO. 3 FROM STATION -L- 17+00, 6' RT TO -L- 19+78, 3' RT
 LOCATION NO. 4 FROM STATION -L- 22+09, 3' RT TO -L- 25+00, 6' RT

BEFORE BEGINNING TEMPORARY SHORING DESIGN OR CONSTRUCTION, SURVEY EXISTING GROUND ELEVATIONS IN THE VICINITY OF SHORING LOCATIONS TO DETERMINE ACTUAL SHORING HEIGHTS.

DESIGN TEMPORARY SHORING LOCATION NOS. 3 AND NO. 4, FOR THE FOLLOWING ASSUMED SOIL PARAMETERS AND GROUNDWATER ELEVATION:
 UNIT WEIGHT (γ) = 120 PCF
 FRICTION ANGLE (ϕ) = 30 DEGREES
 COHESION (c) = 0 PSF
 GROUNDWATER ELEVATION = N/A

LIMITED SUBSURFACE INFORMATION IS AVAILABLE IN THE VICINITY OF TEMPORARY SHORING LOCATION NOS. 3 AND NO. 4. THE INFORMATION PROVIDED FOR TEMPORARY SHORING DESIGN WAS ASSUMED AND MAY NOT BE APPLICABLE TO THE ACTUAL SITE CONDITIONS ENCOUNTERED DURING CONSTRUCTION.

AT THE CONTRACTOR'S OPTION, USE A STANDARD TEMPORARY WALL FOR TEMPORARY SHORING LOCATION NOS. 3 AND NO. 4. SEE GEOTECHNICAL STANDARD DETAIL NO. 1801.02 FOR STANDARD TEMPORARY WALLS.

WHEN BACKFILL FOR RETAINING WALLS AND BRIDGE APPROACH FILLS OVERLAPS WITH THE REINFORCED ZONE OF TEMPORARY WALLS, USE SHORING BACKFILL OR BACKFILL MATERIAL REQUIRED FOR RETAINING WALLS AND BRIDGE APPROACH FILLS, WHICHEVER IS BETTER, IN THE REINFORCED ZONE OF TEMPORARY WALLS.

Shoring Location No. 5 and 6

FOR TEMPORARY SHORING AND POSITIVE PROTECTION FOR TEMPORARY SHORING, SEE PLANS AND TEMPORARY SHORING PROVISION
 TEMPORARY SHORING LOCATION RANGES:
 LOCATION NO. 5 FROM STATION -Y1- 25+29, 10' RT TO -Y1- 26+59, 12' RT
 LOCATION NO. 6 FROM STATION -Y1- 25+27, 13' LT TO -Y1- 26+54, 12' LT

BEFORE BEGINNING TEMPORARY SHORING DESIGN OR CONSTRUCTION, SURVEY EXISTING GROUND ELEVATIONS IN THE VICINITY OF SHORING LOCATIONS TO DETERMINE ACTUAL SHORING HEIGHTS.

DESIGN TEMPORARY SHORING LOCATION NOS. 5 AND NO. 6, FOR THE FOLLOWING ASSUMED SOIL PARAMETERS AND GROUNDWATER ELEVATION:
 UNIT WEIGHT (γ) = 120 PCF
 FRICTION ANGLE (ϕ) = 30 DEGREES
 COHESION (c) = 0 PSF
 GROUNDWATER ELEVATION = N/A

LIMITED SUBSURFACE INFORMATION IS AVAILABLE IN THE VICINITY OF TEMPORARY SHORING LOCATION NOS. 5 AND NO. 6. THE INFORMATION PROVIDED FOR TEMPORARY SHORING DESIGN WAS ASSUMED AND MAY NOT BE APPLICABLE TO THE ACTUAL SITE CONDITIONS ENCOUNTERED DURING CONSTRUCTION.

DRIVEN PILING FOR TEMPORARY SHORING LOCATION NOS. 5 AND NO. 6 WILL NOT PENETRATE BELOW ELEVATION 785 FT DUE TO OBSTRUCTIONS, VERY DENSE OR HARD SOIL, BOULDERS OR WEATHERED OR HARD ROCK.

AT THE CONTRACTOR'S OPTION, USE STANDARD TEMPORARY SHORING FOR TEMPORARY SHORING LOCATION NOS. 5 AND NO. 6. SEE GEOTECHNICAL STANDARD DETAIL NO. 1801.01 FOR STANDARD TEMPORARY SHORING.

THE TEMPORARY SHORING NOTES SHOWN ON THIS SHEET WERE PROVIDED THROUGH A SEALED DOCUMENT FROM THE GEOTECHNICAL ENGINEERING UNIT. THE DOCUMENT WAS SUBMITTED TO THE WZTC SECTION ON 3-4-2026 AND SEALED BY A PROFESSIONAL ENGINEER, MICHAEL H. STEPHENS, LICENSE #028893.

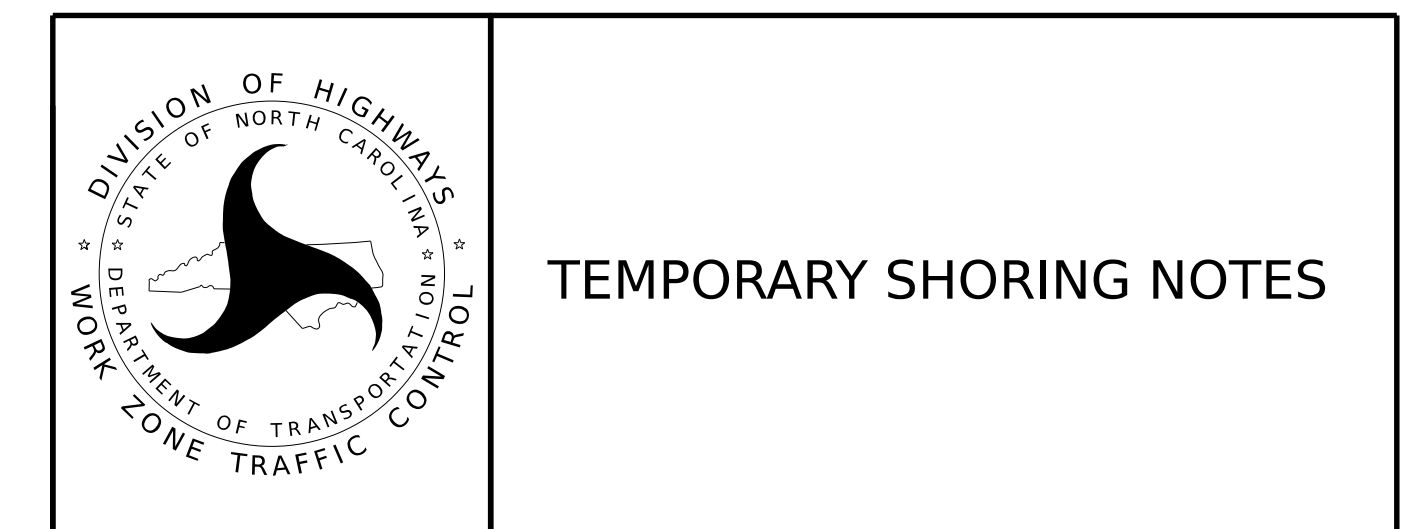

GENERAL NOTES

CHANGES MAY BE REQUIRED WHEN PHYSICAL DIMENSIONS IN THE DETAIL DRAWINGS, STANDARD DETAILS, AND ROADWAY DETAILS ARE NOT ATTAINABLE TO MEET FIELD CONDITIONS OR RESULT IN DUPLICATE OR UNDESIRE OVERLAPPING OF DEVICES. MODIFICATION MAY INCLUDE: MOVING, SUPPLEMENTING, COVERING, OR REMOVAL OF DEVICES AS DIRECTED BY THE ENGINEER.

THE FOLLOWING GENERAL NOTES APPLY AT ALL TIMES FOR THE DURATION OF THE CONSTRUCTION PROJECT EXCEPT WHEN OTHERWISE NOTED IN THE PLAN OR DIRECTED BY THE ENGINEER.

TIME RESTRICTIONS

A) DO NOT CLOSE OR NARROW TRAVEL LANES AS FOLLOWS:

ROAD NAME	DAY AND TIME RESTRICTIONS
UNIVERSITY PKWY US 52 INCL RAMPS/LOOPS	MONDAY - SUNDAY 6:00 AM TO 8:00 PM

B) DO NOT CLOSE OR NARROW TRAVEL LANES DURING HOLIDAYS AND SPECIAL EVENTS AS FOLLOWS:

ROAD NAME

UNIVERSITY PKWY
US 52 INCL RAMPS/LOOPS

HOLIDAY

- FOR ANY UNEXPECTED OCCURRENCE THAT CREATES UNUSUALLY HIGH TRAFFIC VOLUMES, AS DIRECTED BY THE ENGINEER.
- FOR NEW YEAR'S, BETWEEN THE HOURS OF 6:00 A.M. DECEMBER 31st TO 8:00 P.M. JANUARY 2ND. IF NEW YEAR'S DAY IS ON A FRIDAY, SATURDAY, SUNDAY, OR MONDAY THEN UNTIL 8:00 P.M. THE FOLLOWING TUESDAY.
- FOR EASTER, BETWEEN THE HOURS OF 6:00 A.M. THURSDAY AND 8:00 P.M. MONDAY.
- FOR MEMORIAL DAY, BETWEEN THE HOURS OF 6:00 A.M. FRIDAY TO 8:00 P.M. TUESDAY.
- FOR INDEPENDENCE DAY, BETWEEN THE HOURS OF 6:00 A.M. THE DAY BEFORE INDEPENDENCE DAY AND 8:00 P.M. THE DAY AFTER INDEPENDENCE DAY.

IF INDEPENDENCE DAY IS ON A FRIDAY, SATURDAY, SUNDAY OR MONDAY THEN BETWEEN THE HOURS OF 6:00 A.M. THE THURSDAY BEFORE INDEPENDENCE DAY AND 8:00 P.M. THE TUESDAY AFTER INDEPENDENCE DAY.
- FOR LABOR DAY, BETWEEN THE HOURS OF 6:00 A.M. FRIDAY AND 8:00 P.M. TUESDAY.
- FOR THANKSGIVING DAY, BETWEEN THE HOURS OF 6:00 A.M. TUESDAY TO 8:00 P.M. MONDAY.
- FOR CHRISTMAS, BETWEEN THE HOURS OF 6:00 A.M. THE FRIDAY BEFORE THE WEEK OF CHRISTMAS DAY AND 8:00 P.M. THE FOLLOWING TUESDAY AFTER THE WEEK OF CHRISTMAS.
- FOR CAROLINA CLASSIC FAIR, BETWEEN THE HOURS OF 6:00 AM THE DAY BEFORE THE START OF THE CAROLINA CLASSIC FAIR AND 8:00 PM THE FOLLOWING DAY AFTER THE END OF THE CAROLINA CLASSIC FAIR.
- FOR WAKE FOREST UNIVERSITY EVENTS, OCCURRING AT TRUIST FIELD AT WAKE FOREST UNIVERSITY BETWEEN 4 HOURS BEFORE THE START AND 4 HOURS AFTER THE END OF EACH EVENT.

C1) DO NOT CLOSE ROADS AS FOLLOWS:

ROAD NAME	DAY AND TIME RESTRICTIONS	OPERATION
US-52	MONDAY-SUNDAY 6:00AM - 11:00PM	GIRDER HANGING/REMOVAL

C2) DO NOT STOP TRAFFIC AS FOLLOWS:

ROAD NAME	DAY AND TIME RESTRICTIONS	DURATION AND OPERATION
UNIVERSITY PKWY	MONDAY-SUNDAY 6:00AM - 11:00PM	20 MIN TRAFFIC SHIFTS

D) DO NOT CONDUCT ANY HAULING OPERATIONS AGAINST THE FLOW OF TRAFFIC OF AN OPEN TRAVELWAY UNLESS THE HAULING OPERATION IS PROTECTED BY BARRIER OR GUARDRAIL OR AS DIRECTED BY THE ENGINEER.

LANE AND SHOULDER CLOSURE REQUIREMENTS

E) REMOVE LANE CLOSURE DEVICES FROM THE LANE WHEN WORK IS NOT BEING PERFORMED BEHIND THE LANE CLOSURE OR WHEN A LANE CLOSURE IS NO LONGER NEEDED OR AS DIRECTED BY THE ENGINEER.

F) WHEN PERSONNEL AND/OR EQUIPMENT ARE WORKING WITHIN 15 FT OF AN OPEN TRAVEL LANE, CLOSE THE NEAREST OPEN SHOULDER USING ROADWAY STANDARD DRAWING NO. 1101.04 UNLESS THE WORK AREA IS PROTECTED BY BARRIER OR GUARDRAIL OR A LANE CLOSURE IS INSTALLED.

G) WHEN PERSONNEL AND/OR EQUIPMENT ARE WORKING WITHIN 5 FT OF AN OPEN TRAVEL LANE ON AN UNDIVIDED FACILITY, CLOSE THE NEAREST OPEN TRAVEL LANE USING ROADWAY STANDARD DRAWING NO. 1101.02 UNLESS THE WORK AREA IS PROTECTED BY BARRIER OR GUARDRAIL.

WHEN PERSONNEL AND/OR EQUIPMENT ARE WORKING WITHIN 10 FT OF AN OPEN TRAVEL LANE ON A DIVIDED FACILITY, CLOSE THE NEAREST OPEN TRAVEL LANE USING ROADWAY STANDARD DRAWING NO. 1101.02 UNLESS THE WORK AREA IS PROTECTED BY BARRIER OR GUARDRAIL.

H) WHEN PERSONNEL AND/OR EQUIPMENT ARE WORKING WITHIN A LANE OF TRAVEL OF AN UNDIVIDED OR DIVIDED FACILITY, CLOSE THE LANE ACCORDING TO THE TRAFFIC CONTROL PLANS, ROADWAY STANDARD DRAWINGS, OR AS DIRECTED BY THE ENGINEER. CONDUCT THE WORK SO THAT ALL PERSONNEL AND/OR EQUIPMENT REMAIN WITHIN THE CLOSED TRAVEL LANE.

I) DO NOT WORK SIMULTANEOUSLY WITHIN 15 FT ON BOTH SIDES OF AN OPEN TRAVELWAY, RAMP, OR LOOP WITHIN THE SAME LOCATION UNLESS PROTECTED WITH GUARDRAIL OR BARRIER.

J) USE SEQUENTIAL FLASHING WARNING LIGHTS ON DRUMS USED FOR THE MERGING TAPERS OF NIGHTTIME LANE CLOSURES IN ACCORDANCE WITH SECTION 1140 IN THE STANDARD SPECIFICATIONS FOR ROADS AND STRUCTURES.

K) NOTIFY THE NCDOT STATEWIDE TRANSPORTATION OPERATIONS CENTER (STOC) AT 877-627-7862 APPROXIMATELY 30 MINUTES PRIOR TO INSTALLING AND WITHIN 15 MINUTES AFTER REMOVING LANE CLOSURES ON INTERSTATES, FREEWAYS, CONTROLLED ACCESS FACILITIES, AND US ROUTES.

PAVEMENT EDGE DROP OFF REQUIREMENTS

L) BACKFILL AT A 6:1 SLOPE UP TO THE EDGE AND ELEVATION OF EXISTING PAVEMENT IN AREAS ADJACENT TO AN OPENED TRAVEL LANE THAT HAS AN EDGE OF PAVEMENT DROP-OFF AS FOLLOWS:

BACKFILL DROP-OFFS THAT EXCEED 2 INCHES ON ROADWAYS WITH POSTED SPEED LIMITS OF 45 MPH OR GREATER.



BACKFILL DROP-OFFS THAT EXCEED 3 INCHES ON ROADWAYS WITH POSTED SPEED LIMITS LESS THAN 45 MPH.

BACKFILL WITH SUITABLE COMPACTED MATERIAL, AS APPROVED BY THE ENGINEER, AT NO EXPENSE TO THE DEPARTMENT.

M) DO NOT EXCEED A DIFFERENCE OF 2 INCHES IN ELEVATION BETWEEN OPEN LANES OF TRAFFIC FOR NOMINAL LIFTS OF 1.5 INCHES. INSTALL ADVANCE WARNING "UNEVEN LANES" SIGNS (W8-11) 500 IN ADVANCE AND A MINIMUM OF EVERY HALF MILE THROUGHOUT THE UNEVEN AREA.

TRAFFIC PATTERN ALTERATIONS

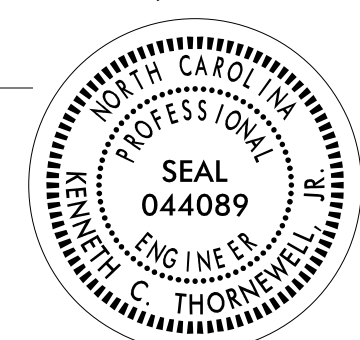
N) NOTIFY THE ENGINEER THIRTY (30) CALENDAR DAYS PRIOR TO ANY TRAFFIC PATTERN ALTERATION.

APPROVED: <i>Kenneth C. Thornwell Jr., P.E.</i> DATE: 03/06/2026 SEAL			<h2 style="margin: 0;">GENERAL NOTES</h2>
DOCUMENT NOT CONSIDERED FINAL UNLESS ALL SIGNATURES COMPLETED			

SIGNING

O) INSTALL ADVANCE WORK ZONE WARNING SIGNS WHEN WORK IS WITHIN 40 FT FROM THE EDGE OF TRAVEL LANE AND NO MORE THAN THREE (3) DAYS PRIOR TO THE BEGINNING OF CONSTRUCTION.

P) PROVIDE SIGNING AND DEVICES REQUIRED TO CLOSE THE ROAD ACCORDING TO THE ROADWAY STANDARD DRAWINGS AND TRAFFIC CONTROL PLANS.

PROVIDE SIGNING REQUIRED FOR THE OFF-SITE DETOUR ROUTE AS SHOWN IN THE TRAFFIC CONTROL PLANS.

Q) COVER OR REMOVE ALL SIGNS AND DEVICES REQUIRED TO CLOSE THE ROAD WHEN ROAD CLOSURE IS NOT IN OPERATION.

COVER OR REMOVE ALL SIGNS REQUIRED FOR THE OFF-SITE DETOUR WHEN THE DETOUR IS NOT IN OPERATION.

R) ENSURE ALL NECESSARY SIGNING IS IN PLACE PRIOR TO ALTERING ANY TRAFFIC PATTERN.

TRAFFIC BARRIER

S) INSTALL TEMPORARY BARRIER ACCORDING TO THE TRANSPORTATION MANAGEMENT PLANS A MAXIMUM OF TWO (2) WEEKS PRIOR TO BEGINNING WORK IN ANY LOCATION. ONCE TEMPORARY BARRIER IS INSTALLED AT ANY LOCATION PROCEED IN A CONTINUOUS MANNER TO COMPLETE THE PROPOSED WORK IN THAT LOCATION UNLESS OTHERWISE STATED IN THE TRANSPORTATION MANAGEMENT PLANS OR AS DIRECTED BY THE ENGINEER.

DO NOT PLACE BARRIER DIRECTLY ON ANY SURFACE OTHER THAN ASPHALT OR CONCRETE.

ONCE TEMPORARY BARRIER IS INSTALLED AT ANY LOCATION AND NO WORK IS PERFORMED BEHIND THE TEMPORARY BARRIER FOR A PERIOD LONGER THAN TWO (2) MONTHS, REMOVE / RESET TEMPORARY BARRIER AT NO COST TO THE DEPARTMENT UNLESS OTHERWISE STATED IN THE TRANSPORTATION MANAGEMENT PLANS, TEMPORARY BARRIER IS PROTECTING A HAZARD, OR AS DIRECTED BY THE ENGINEER.

INSTALL TEMPORARY BARRIER WITH THE TRAFFIC FLOW BEGINNING WITH THE UPSTREAM SIDE OF TRAFFIC. REMOVE TEMPORARY BARRIER AGAINST THE TRAFFIC FLOW BEGINNING WITH THE DOWNSTREAM SIDE OF TRAFFIC.

INSTALL AND SPACE DRUMS NO GREATER THAN TWICE THE POSTED SPEED LIMIT (MPH) TO CLOSE OR KEEP THE SECTION OF THE ROADWAY CLOSED UNTIL THE TEMPORARY BARRIER CAN BE PLACED OR AFTER THE TEMPORARY BARRIER IS REMOVED.

T) PROTECT THE APPROACH END OF MOVABLE/PORTABLE CONCRETE BARRIER AT ALL TIMES DURING THE INSTALLATION AND REMOVAL OF THE BARRIER BY EITHER A TRUCK MOUNTED ATTENUATOR (MAXIMUM 72 HOURS) OR A TEMPORARY CRASH CUSHION.

PROTECT THE APPROACH END OF MOVABLE/PORTABLE CONCRETE BARRIER FROM ONCOMING TRAFFIC AT ALL TIMES BY A TEMPORARY CRASH CUSHION UNLESS THE APPROACH END OF MOVABLE/PORTABLE CONCRETE BARRIER IS OFFSET FROM ONCOMING TRAFFIC AS FOLLOWS OR AS SHOWN IN THE PLANS: (SEE ALSO 1101.05)

POSTED SPEED LIMIT	MINIMUM OFFSET
40 OR LESS	15 FT
45 - 50	20 FT
55	25 FT
60 MPH or HIGHER	30 FT

TRAFFIC CONTROL DEVICES

U) WHEN LANE CLOSURES ARE NOT IN EFFECT SPACE CHANNELIZING DEVICES IN WORK AREAS NO GREATER IN FEET THAN TWICE THE POSTED SPEED LIMIT (MPH) EXCEPT, 10 FT ON-CENTER IN RADII, AND 3 FT OFF THE EDGE OF AN OPEN TRAVELWAY. REFER TO STANDARD SPECIFICATIONS FOR ROADS AND STRUCTURES SECTIONS 1130 (DRUMS), 1135 (CONES) AND 1180 (SKINNY DRUMS) FOR ADDITIONAL REQUIREMENTS.

V) PLACE TYPE III BARRICADES, WITH "ROAD CLOSED" SIGN R11-2 ATTACHED, OF SUFFICIENT LENGTH TO CLOSE ENTIRE ROADWAY.

W) PLACE ADDITIONAL SETS OF THREE CHANNELIZING DEVICES DRUMS PERPENDICULAR TO THE EDGE OF TRAVELWAY ON 500 FT CENTERS WHEN UNOPENED LANES ARE CLOSED TO TRAFFIC.

PAVEMENT MARKINGS AND MARKERS

X) INSTALL TEMPORARY PAVEMENT MARKINGS AND TEMPORARY PAVEMENT MARKERS ON INTERIM LAYERS OF PAVEMENT AS FOLLOWS:

ROAD NAME	MARKING	MARKER
UNIVERSITY PKWY	PAINT	TEMPORARY RAISED
US 52	PAINT	TEMPORARY RAISED

Y) PLACE ONE APPLICATION OF PAINT FOR TEMPORARY TRAFFIC PATTERNS. PLACE A SECOND APPLICATION OF PAINT SIX (6) MONTHS AFTER THE INITIAL APPLICATION AND EVERY SIX MONTHS AS DIRECTED BY THE ENGINEER.

Z) TIE PROPOSED PAVEMENT MARKING LINES TO EXISTING PAVEMENT MARKING LINES.

AA) REMOVE/REPLACE ANY CONFLICTING/DAMAGED PAVEMENT MARKINGS AND MARKERS BY THE END OF EACH DAY'S OPERATION.

BB) TRACE THE PROPOSED MONOLITHIC ISLAND LOCATIONS WITH PROPER COLOR PAVEMENT MARKINGS PRIOR TO INSTALLATION. PLACE DRUMS TO DELINEATE ANY PROPOSED MONOLITHIC ISLANDS BEFORE INSTALLATION

MISCELLANEOUS

CC) LAW ENFORCEMENT MAY BE USED TO MAINTAIN TRAFFIC THROUGH THE WORK AREA AND/OR INTERSECTIONS AS DIRECTED BY THE ENGINEER.

MANAGEMENT STRATEGIES

THE FOLLOWING LISTED WORK ZONE STRATEGIES ARE RECOMMENDED FOR INCLUSION WITHIN THIS TRANSPORTATION MANAGEMENT PLAN (TMP).

RECOMMENDED STRATEGIES:

TRAFFIC MANAGEMENT STRATEGIES:

- LANE SHIFTS OR CLOSURES
- SHOULDER CLOSURES
- ONE-LANE, TWO WAY OPERATION (FLAGGING)
- NIGHT WORK
- WEEKEND WORK
- WORK HOUR RESTRICTIONS FOR PEAK TRAVEL
- OFF-SITE DETOURS / USE OF ALTERNATIVE ROUTES

WORK ZONE SAFETY & MOBILITY STRATEGIES:



- TEMPORARY TRAFFIC SIGNALS
- SEQUENTIAL LIGHTING

TRAFFIC / INCIDENT MANAGEMENT & SPEED ENFORCEMENT STRATEGIES:

- CONTRACTING & INNOVATIVE CONSTRUCTION STRATEGIES:
- INTERMEDIATE CONTRACT TIMES / LIQUIDATED DAMAGES

LOCAL NOTE

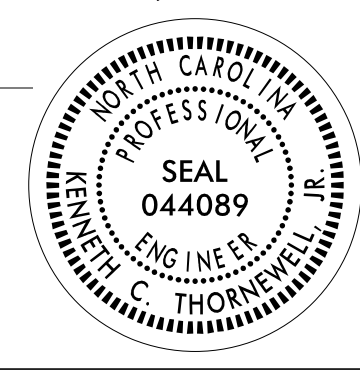
- 1) THE CONTRACTOR SHALL PROVIDE RE-DIRECTIVE CRASH CUSHIONS AS SHOWN IN THIS TMP.

APPROVED: <i>Kenneth C. Thornwell Jr., P.E.</i> DATE: 03/06/2026 SEAL			GENERAL NOTES
DOCUMENT NOT CONSIDERED FINAL UNLESS ALL SIGNATURES COMPLETED			

PHASING

PHASE 1

STEP 1

INSTALL ADVANCE WARNING SIGNS IN ACCORDANCE WITH RSD 1101.01 USING LANE CLOSURES AND FLAGGING OPERATIONS, REMOVE EXISTING CONCRETE MEDIAN AND CONSTRUCT TEMPORARY PAVEMENT AT THE FOLLOWING LOCATIONS (TMP-3.1):

- -L- FROM MERCANTILE DRIVE TO -RPC-
- -RPC- NEAR INTERSECTION OF -L-

INSTALL PAVEMENT MARKINGS OUTLINING THE REMOVED ISLANDS AS SHOWN ON TMP-3.1

STEP 2

ALONG US-52, USING LANE CLOSURES AS NEEDED, PERFORM THE FOLLOWING (TMP-3.2):

NB:

- USING LANE CLOSURES, CONSTRUCT 4' OF TEMPORARY PAVEMENT ALONG THE INSIDE SHOULDER
- NARROW TRAVEL LANES BY 1' AND SHIFT PAVEMENT MARKINGS AS SHOWN
- INSTALL PCB AND CRASH CUSHIONS ALONG THE INSIDE AND OUTSIDE LANES
- REMOVE GUARDRAIL AS NEEDED BEHIND PCB. INSTALL TEMPORARY ANCHOR UNITS WHERE NEEDED

SB:

- USING LANE CLOSURES, CONSTRUCT 4' OF TEMPORARY PAVEMENT ALONG THE INSIDE SHOULDER
- NARROW THROUGH LANES BY 1' AND SHIFT PAVEMENT MARKINGS AS SHOWN
- INSTALL PCB AND CRASH CUSHIONS ALONG THE INSIDE AND OUTSIDE LANES
- REMOVE GUARDRAIL AS NEEDED BEHIND PCB. INSTALL TEMPORARY ANCHOR UNITS AS SHOWN

THE CONTRACTOR SHALL COMPLETE THE WORK REQUIRED IN PHASE 1, STEP 3 STARTING FRIDAY AT 8:00 PM AND ENDING MONDAY AT 6:00 AM (SEE INTERMEDIATE CONTRACT TIME AND LIQUIDATED DAMAGES)

STEP 3

INSTALL 35 MPH STATIC SPEED REDUCTION BOTH DIRECTIONS ON UNIVERSITY PKWY (SEE TMP-5.1) INSTALL DETOUR SIGNS AND DEVICES AS SHOWN ON TMP-2E AND TMP-2F CLOSE NORTHBOUND AND SOUTHBOUND US 52 RAMPS AND LOOPS

USING LANE CLOSURES, FLAGGING OPERATIONS, AND ROAD STOPPAGES, PERFORM THE FOLLOWING (SEE TMP-3.3 AND TMP-3.4):

- INSTALL TEMPORARY SIGNS, PAVEMENT MARKINGS, AND TEMPORARY SIGNALS FOR PHASE 1 TRAFFIC PATTERN
- INSTALL PCB AND REDIRECTIVE CRASH CUSHIONS
- SHIFT TRAFFIC TO PHASE 1 TRAFFIC PATTERN AND REOPEN US 52 RAMPS/LOOPS

STEP 4

AWAY FROM TRAFFIC, INSTALL TEMPORARY SHORING NO. 1 & 2

CLOSE US-52 AS NEEDED DURING ALLOWABLE TIME RESTRICTIONS FOR BRIDGE DEMO/GIRDER ERECTION. SEE TMP-2C AND TMP-2D FOR DETOURS

INSTALL TEMPORARY SHORING NO. 5 & 6 AS NEEDED FOR MEDIAN PIER CONSTRUCTION

AWAY FROM TRAFFIC, COMPLETE WORK REQUIRED FOR STAGE I BRIDGE CONSTRUCTION UP TO BUT NOT INCLUDING FINAL SURFACE. INSTALL TEMPORARY SHORING NO. 3 & 4 AS NEEDED DURING CONSTRUCTION

USING LANE CLOSURES, COMPLETE FULL DEPTH PAVEMENT REPLACEMENT ALONG -L- BETWEEN -RPC- AND MERCANTILE DRIVE

THE CONTRACTOR SHALL COMPLETE THE WORK REQUIRED IN PHASE 1, STEP 5 IN 30 CONSECUTIVE CALENDAR DAYS (SEE INTERMEDIATE CONTRACT TIME AND LIQUIDATED DAMAGES)

STEP 5

INSTALL DETOUR SIGNS AS SHOWN ON TMP-2E AND CLOSE SB US-52 RAMPS. MODIFY EXISTING TEMP SIGNAL TO PLACE UNIVERSITY PARKWAY THROUGH TRAFFIC IN YELLOW FLASH.

COMPLETE THE WORK REQUIRED ON TMP-3.5 INCLUDING OUTSTANDING DRAINAGE ITEMS ALONG THE RAMPS. WEDGE EXISTING PAVEMENT TO TIE IN TO PROPOSED GRADE ALONG -L- TO ALLOW RAMPS TO RE-OPEN

REMOVE DETOUR AND RE-OPEN SB US-52 RAMPS TO TRAFFIC

THE CONTRACTOR SHALL COMPLETE THE WORK REQUIRED IN PHASE 1, STEP 6 IN 30 CONSECUTIVE CALENDAR DAYS (SEE INTERMEDIATE CONTRACT TIME AND LIQUIDATED DAMAGES)

STEP 6

INSTALL DETOUR SIGNS AS SHOWN ON TMP-2F AND CLOSE NB US-52 RAMPS

COMPLETE THE WORK REQUIRED ON TMP-3.6 INCLUDING OUTSTANDING DRAINAGE ITEMS ALONG THE RAMPS

USING LANE CLOSURES, FLAGGING OPERATIONS, AND ROAD STOPPAGES, PERFORM THE FOLLOWING (SEE TMP 4.1 AND TMP-4.2):

- INSTALL TEMPORARY SIGNS, PAVEMENT MARKINGS, AND TEMPORARY SIGNALS FOR PHASE 2 TRAFFIC PATTERN
- INSTALL PCB AND REDIRECTIVE CRASH CUSHIONS
- REMOVE DETOUR, REOPEN NB US-52 RAMPS, AND SHIFT TRAFFIC TO PHASE 2 TRAFFIC PATTERN

PHASE 2

MAINTAIN PCB ALONG US-52 DURING PHASE 2

CLOSE US-52 AS NEEDED DURING ALLOWABLE TIME RESTRICTIONS FOR BRIDGE DEMO/GIRDER ERECTION. SEE TMP-2C AND TMP-2D FOR DETOURS

FINISH INSTALLING SHORING NO. 5 AND NO. 6 AS NEEDED DURING STAGE 2 BRIDGE CONSTRUCTION

AWAY FROM TRAFFIC, COMPLETE WORK REQUIRED FOR STAGE 2 BRIDGE AND ROADWAY CONSTRUCTION UP TO BUT NOT INCLUDING FINAL SURFACE

PHASE 3

ALONG US-52, REMOVE PCB AND RESTORE TRAFFIC TO FINAL PATTERN USING LANE CLOSURES AS NEEDED. SEE ROADWAY PLANS FOR GUARDRAIL AND MEDIAN CONSTRUCTION

ALONG -L-, INSTALL PERMANENT SIGNALS AND SHIFT TRAFFIC TO FINAL PATTERN. REMOVE 35 MPH STATIC SPEED REDUCTION AND RESTORE EXISTING 45 MPH SPEED LIMIT. COMPLETE ANY OUTSTANDING MEDIAN DRAINAGE AND CONSTRUCT MEDIAN ISLANDS USING LANE CLOSURES AS NEEDED

COMPLETE PAVING OF FINAL SURFACE COURSE AND INSTALL FINAL PAVEMENT MARKINGS ACCORDING TO PLANS. MILL, OVERLAY, AND RESTRIPE EXISTING PAVEMENT MODIFIED FOR TRAFFIC CONTROL OUTSIDE ROADWAY LIMITS

3/4/2026
pw:/ncdot-pw.bentley.com/ncdot-pw-01/Documents/Division_09/BR-0168/Work Zone Traffic Control/BR-0168-TC-TMP-02B-Phasing Notes
User: jbeaver1

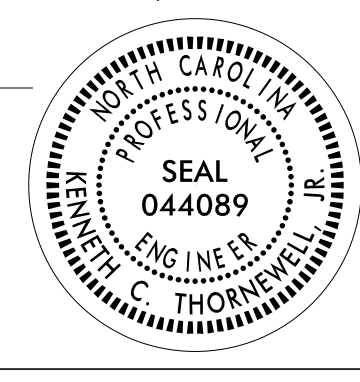
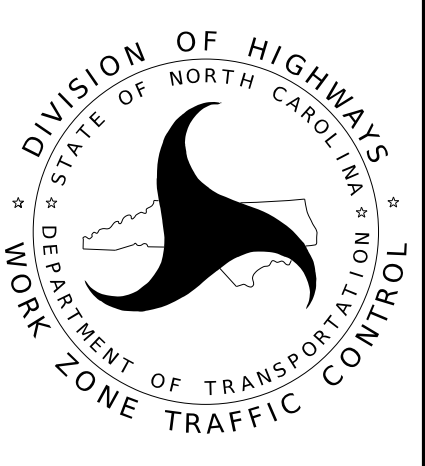
APPROVED: <i>Kenneth C. Thornwell Jr., P.E.</i> <small>1E991EF27373405</small> DATE: 03/06/2026 SEAL			<h1 style="margin: 0;">PHASING</h1>
DOCUMENT NOT CONSIDERED FINAL UNLESS ALL SIGNATURES COMPLETED			

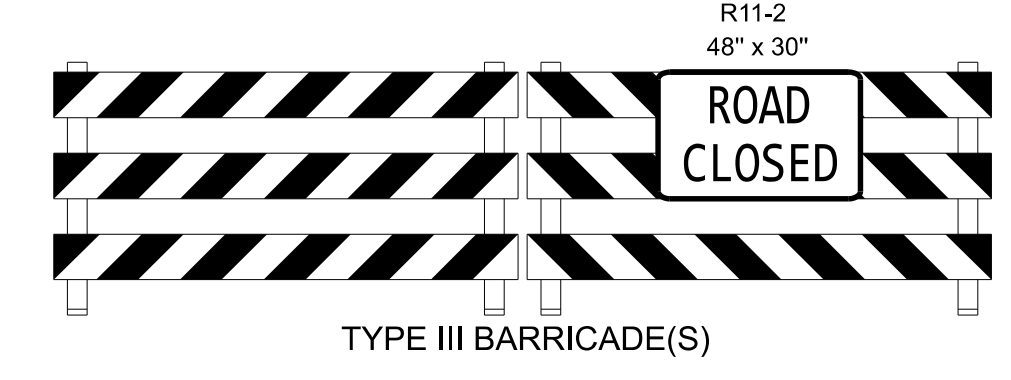
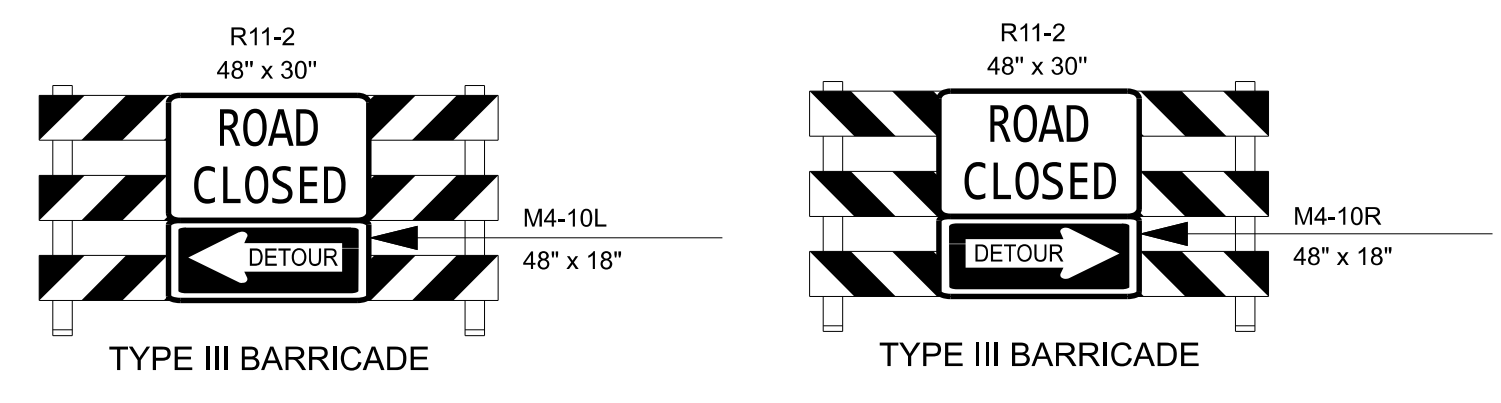
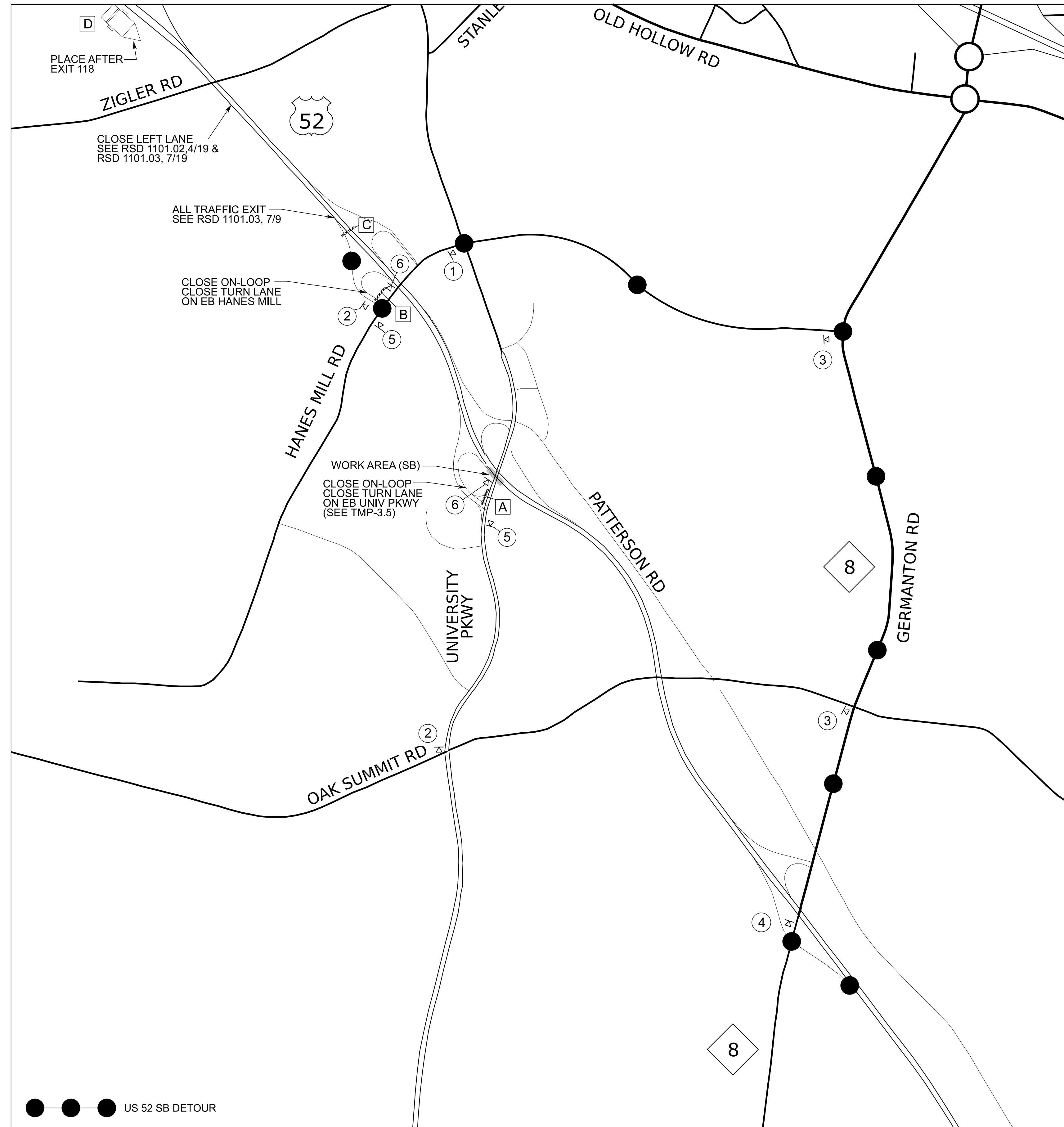

MESSAGE NO. 1	MESSAGE NO. 2
US 52 S CLOSED 2 MILES	ALL TRAFFIC EXIT 116
CHANGEABLE MESSAGE SIGN	

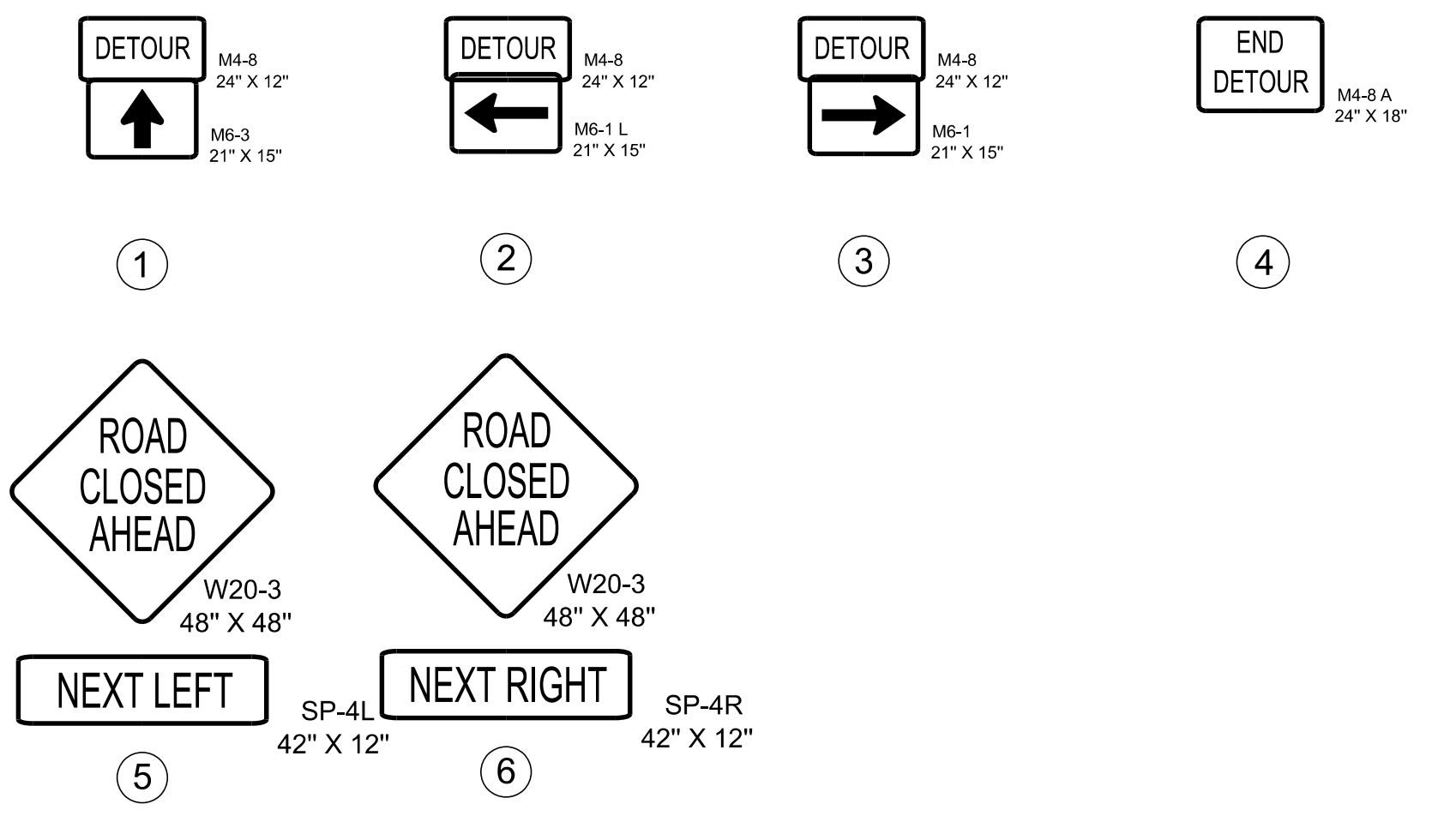

2/10/2026 pw:/ncdot-pw.bentley.com:ncdot-pw-01/Documents/Division_09/BR-0168/Work Zone Traffic Control/BR-0168-TC-TMP-02C-Detour SB Full User: jbeaver1

APPROVED: *Kenneth C. Thornwell Jr., P.E.*
 DATE: 03/06/2026
 SEAL

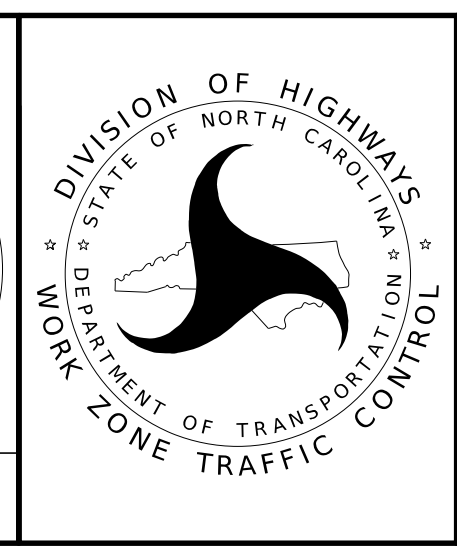
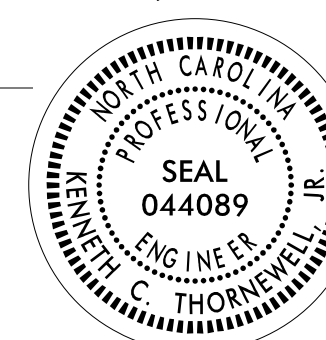

US 52 SOUTH
FULL CLOSURE DETOUR

DOCUMENT NOT CONSIDERED FINAL
UNLESS ALL SIGNATURES COMPLETED

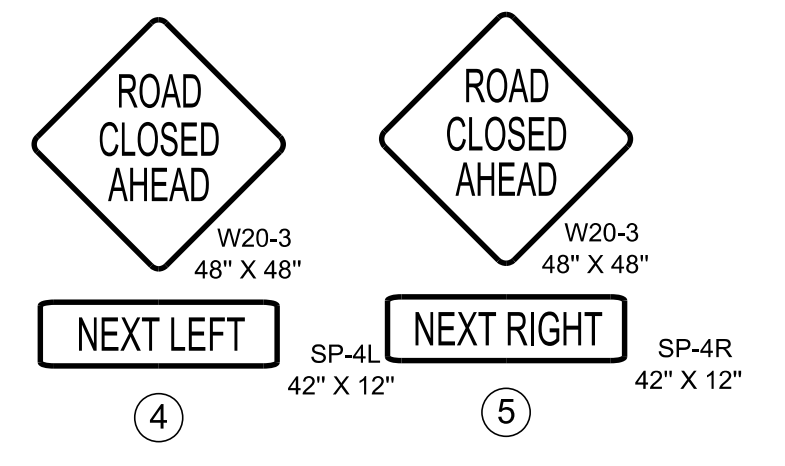
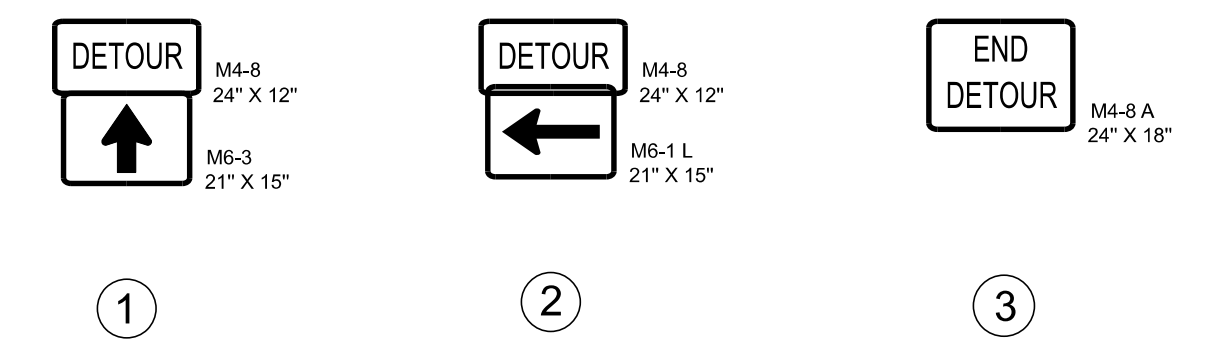
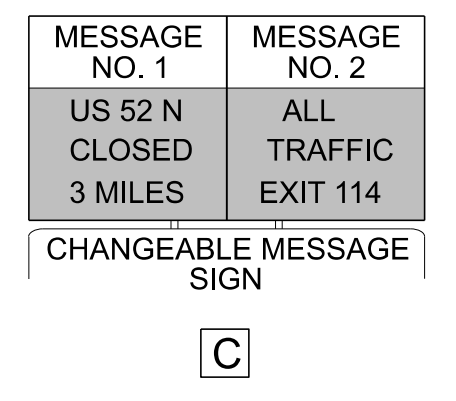
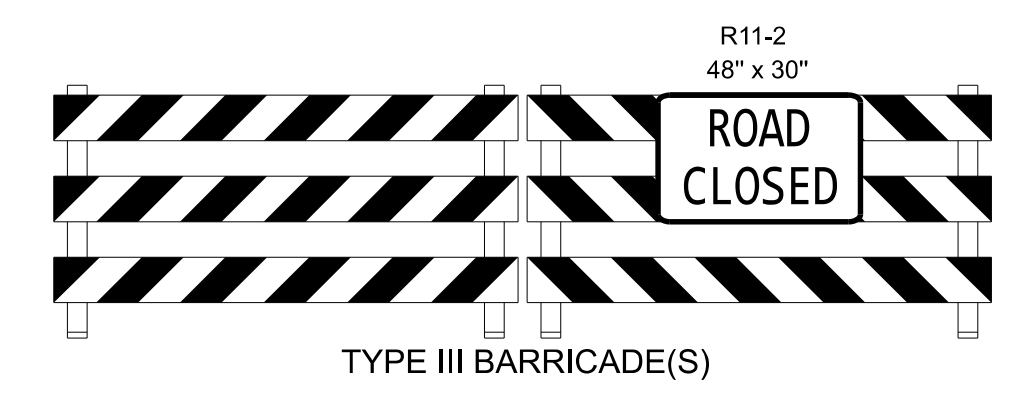
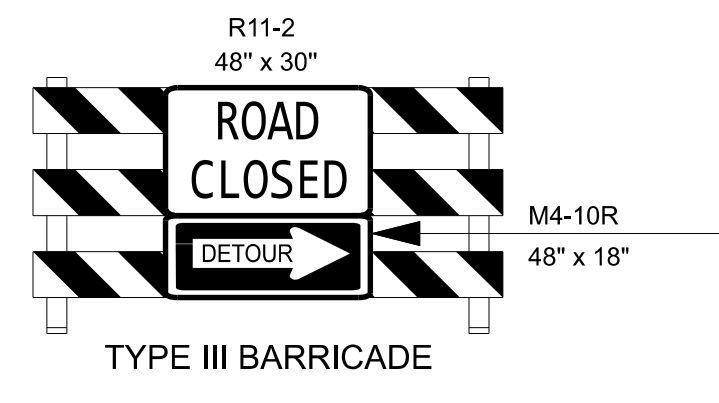
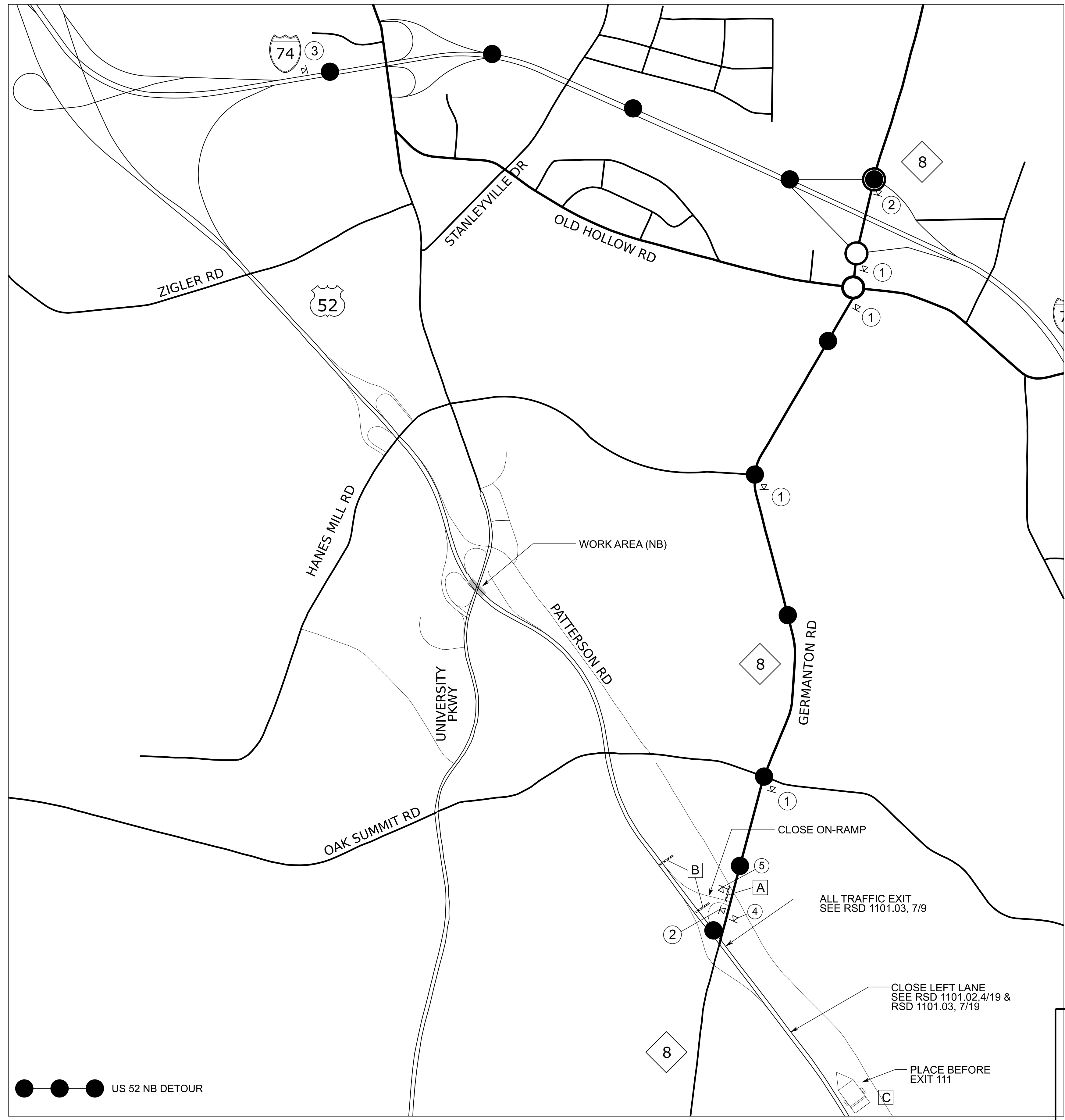

2/10/2026
 pw:/ncdot-pw.bentley.com:ncdot-pw-01/Documents/Division_09/BR-0168/Work Zone Traffic Control/BR-0168-TC-TMP-02D-Detour NB Full
 User: jbeaver1

APPROVED: *Kenneth C. Thornwell Jr., P.E.*
 DATE: 03/06/2026
 SEAL

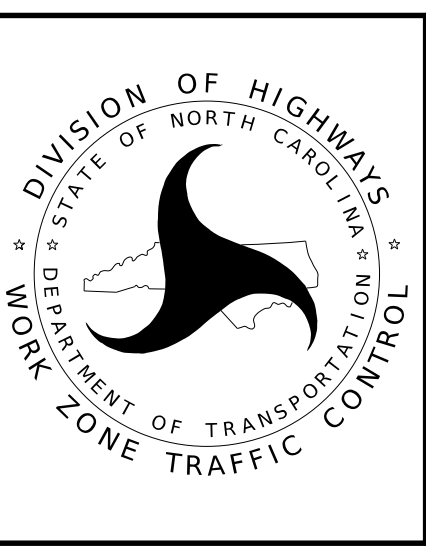
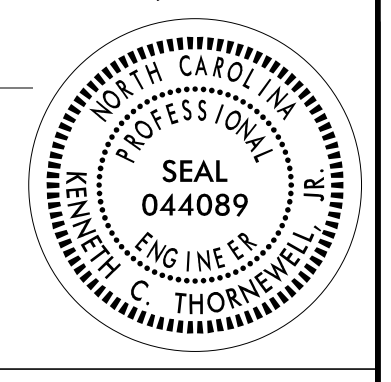

US 52 NORTH
 FULL CLOSURE DETOUR

DOCUMENT NOT CONSIDERED FINAL
 UNLESS ALL SIGNATURES COMPLETED

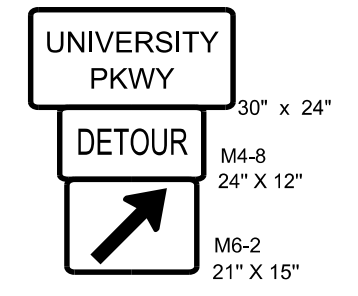
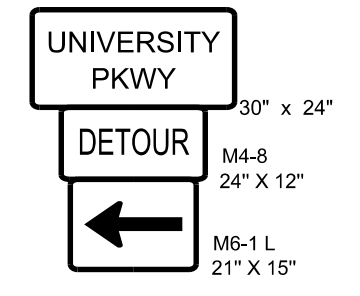
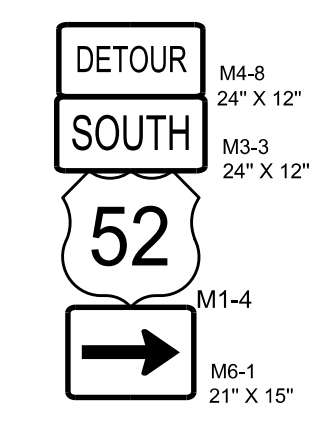
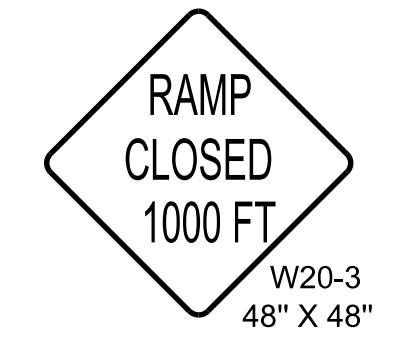
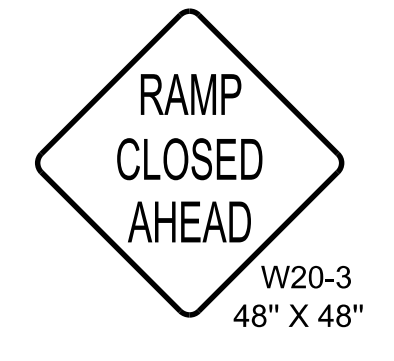
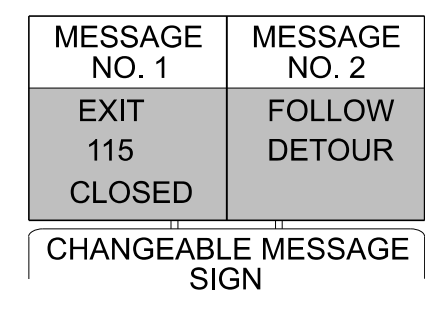
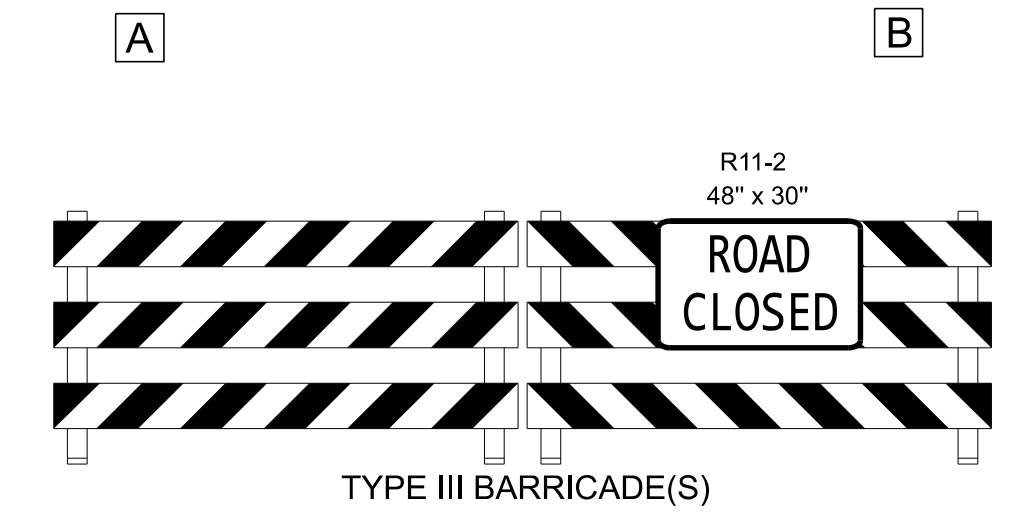
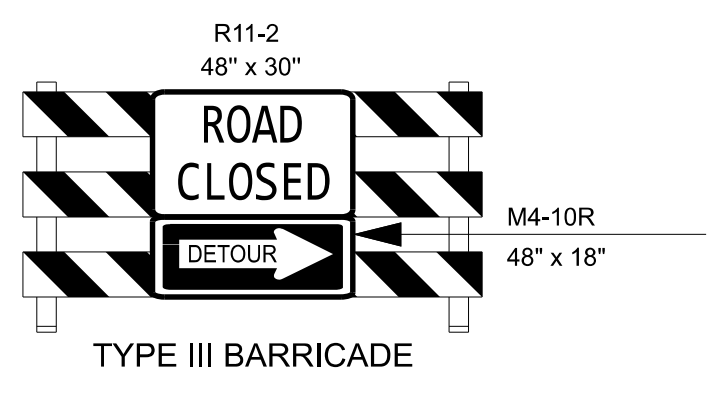
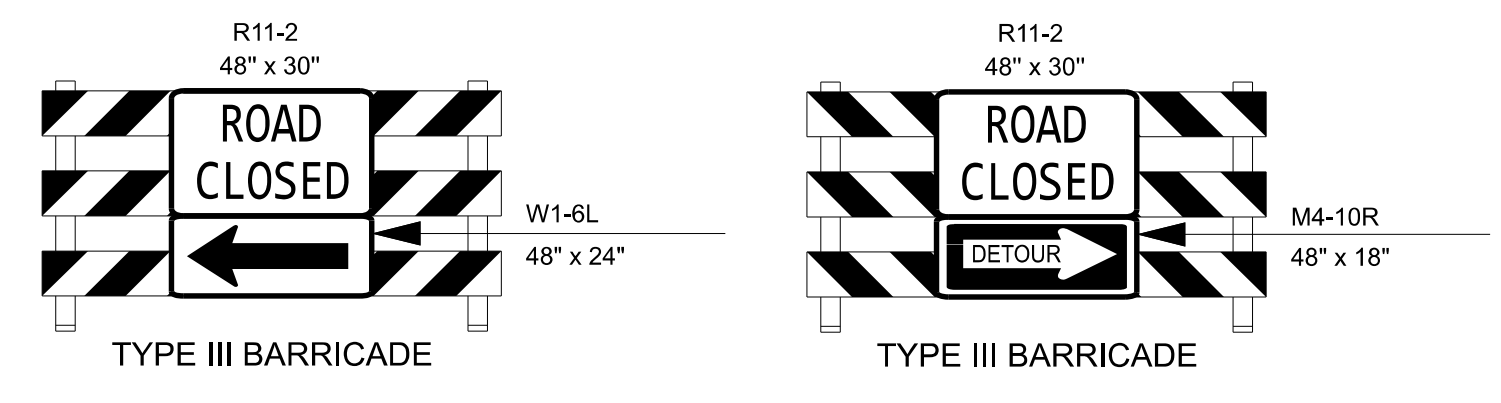
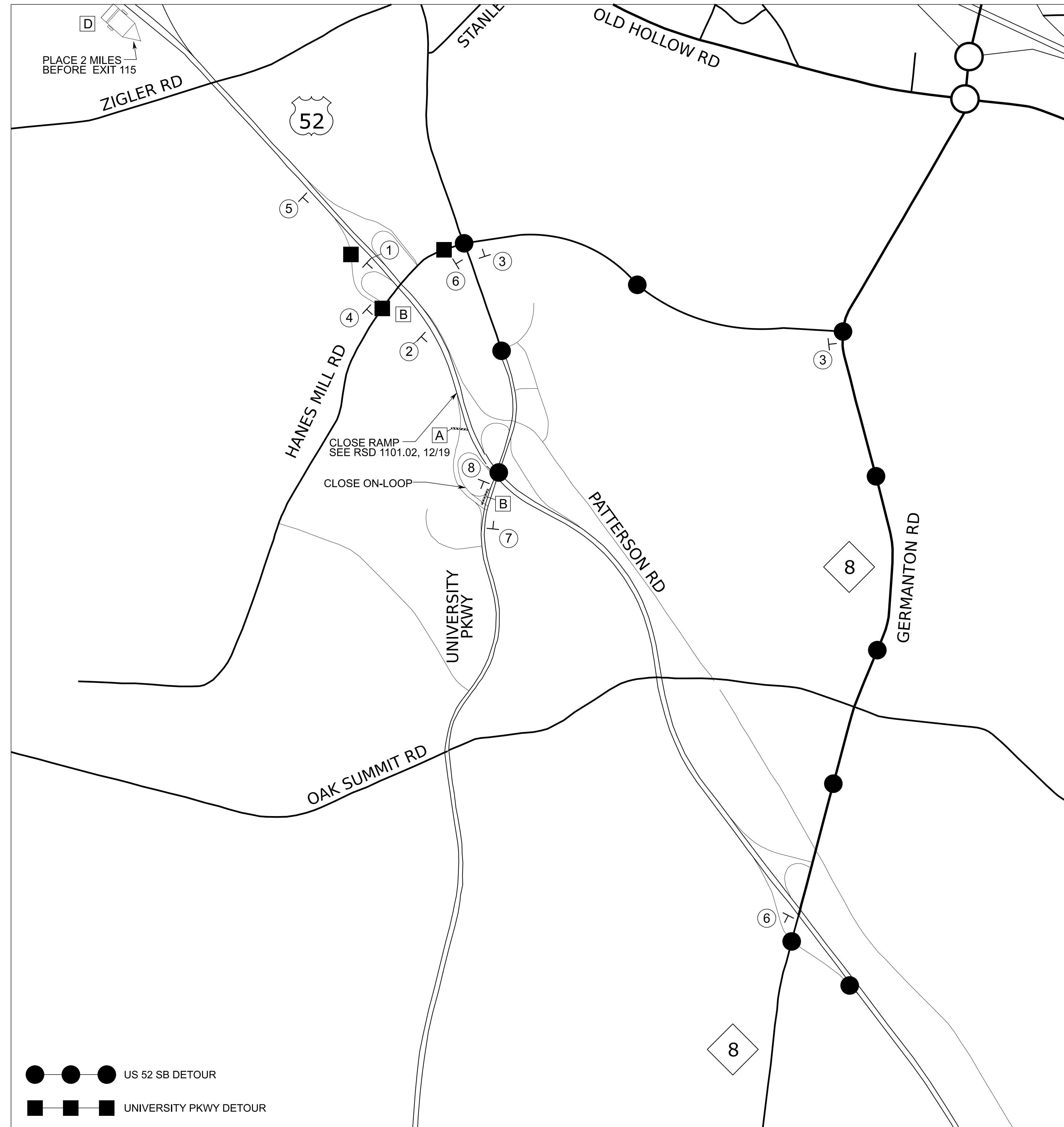

2/10/2026 pw:/ncdot-pw.bentley.com:ncdot-pw-01/Documents/Division_09/BR-0168/Work Zone Traffic Control/BR-0168-TC-TMP-02E-Detour-SB Ramps User:jbave1

APPROVED: *Kenneth C. Thornwell Jr., P.E.*
 DATE: 03/06/2026
 SEAL

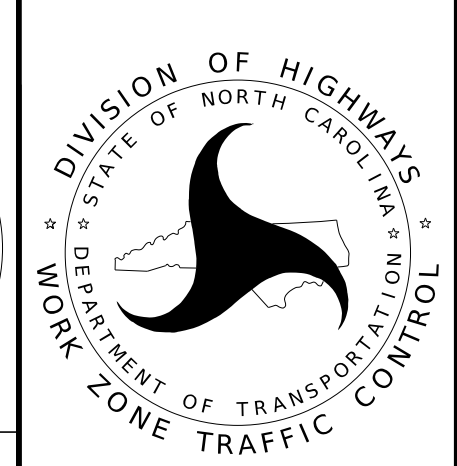
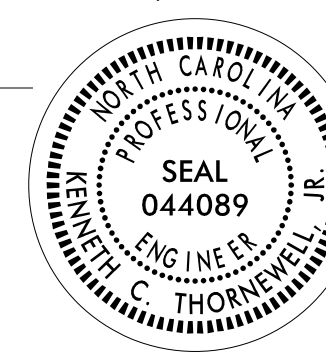

**US 52 SOUTH
RAMP CLOSURES
(30 DAYS)**

DOCUMENT NOT CONSIDERED FINAL
UNLESS ALL SIGNATURES COMPLETED

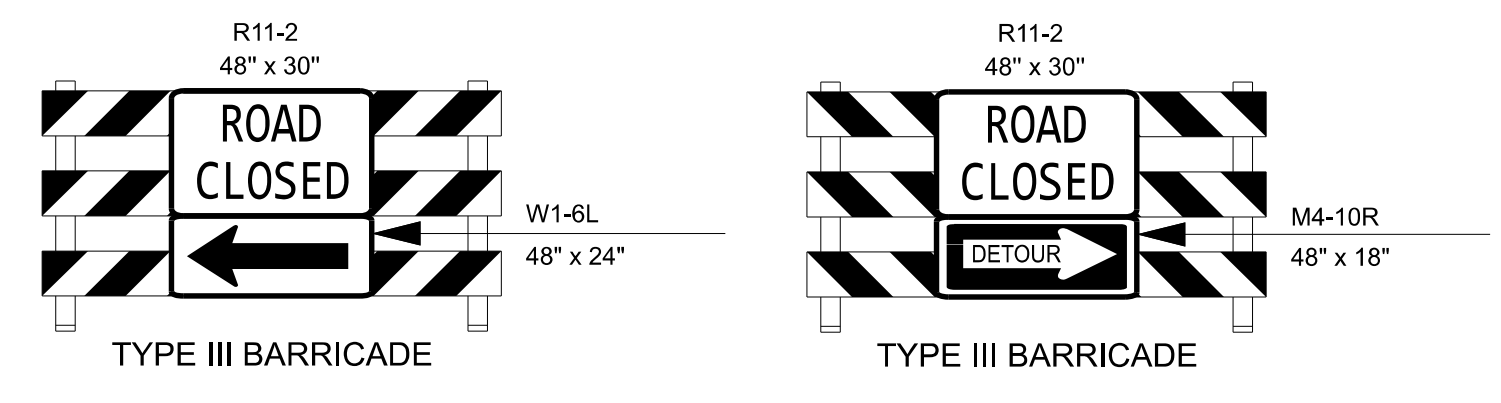
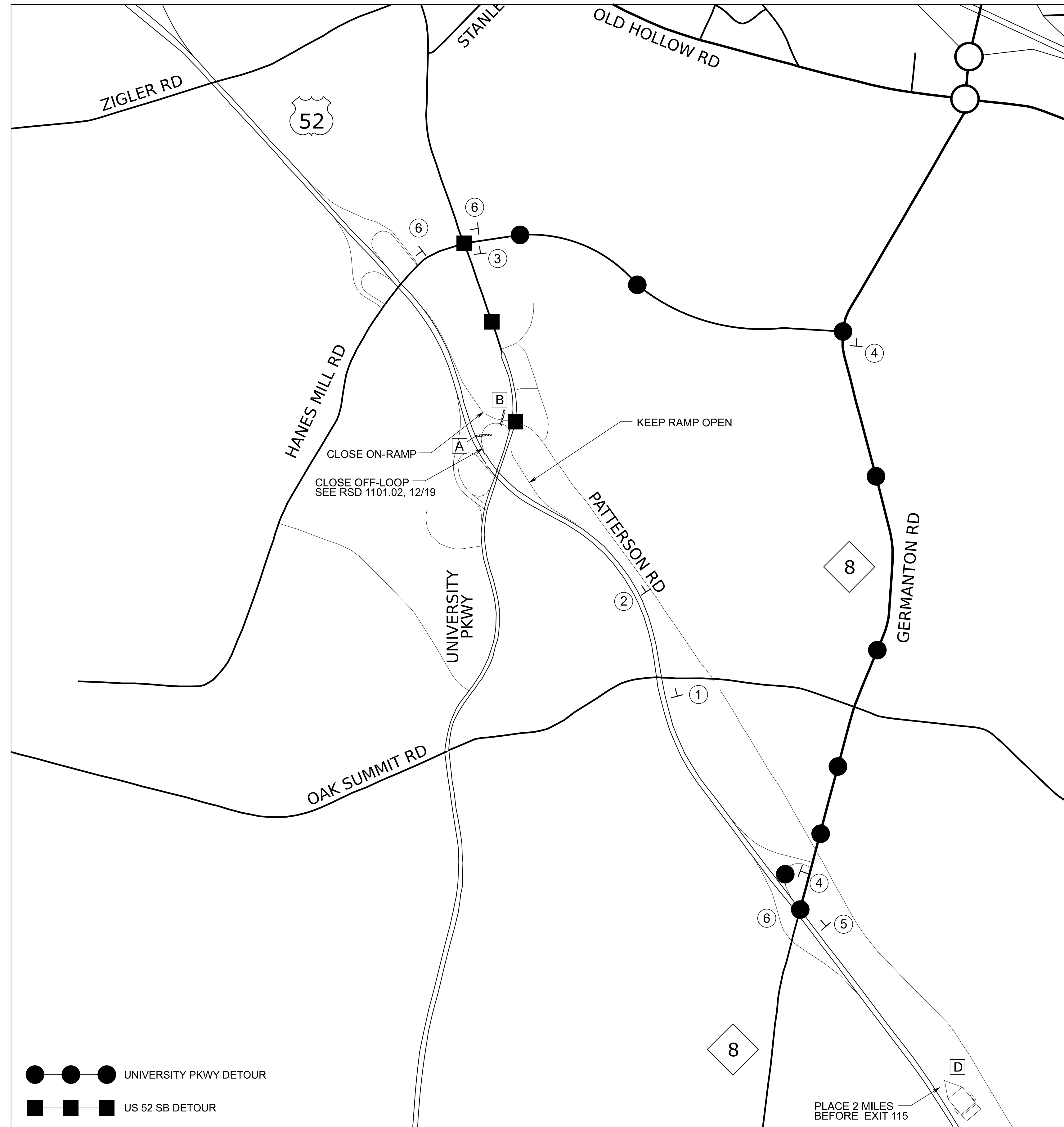

A

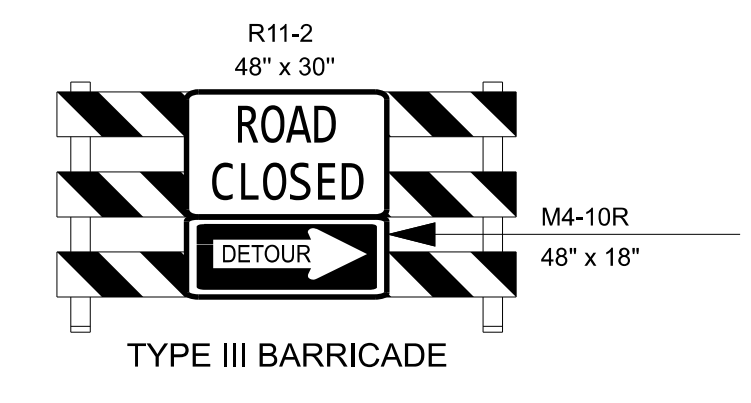

B

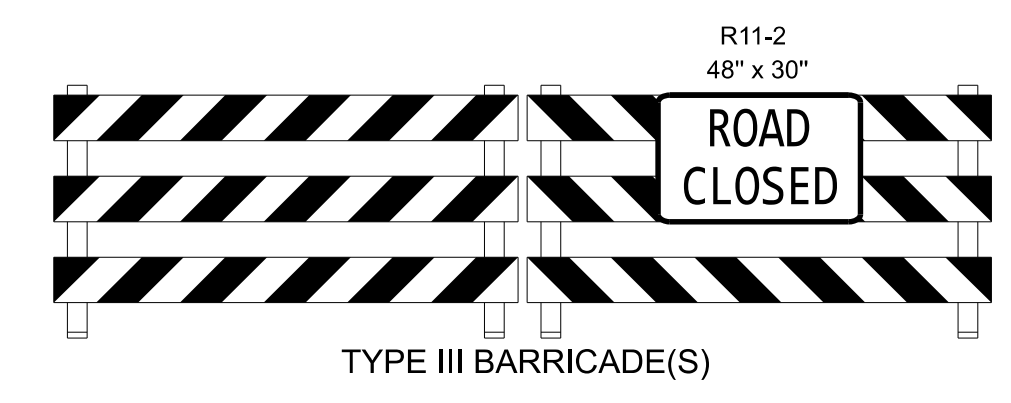

C

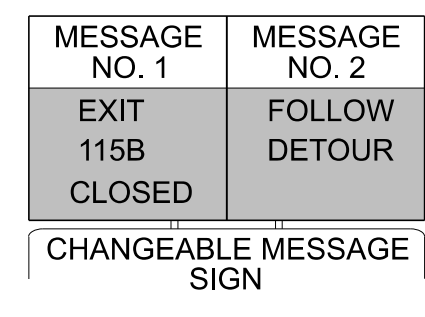

D

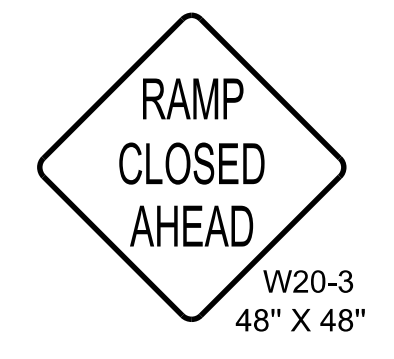

1

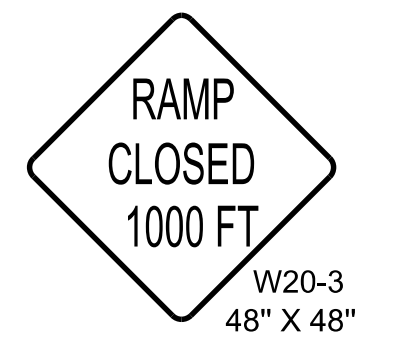

2

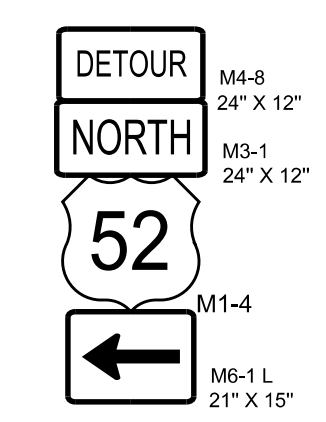

3

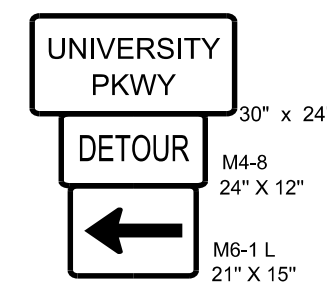

4

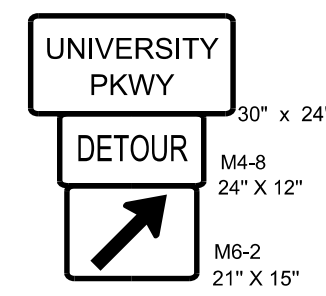

5

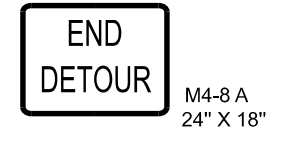

6

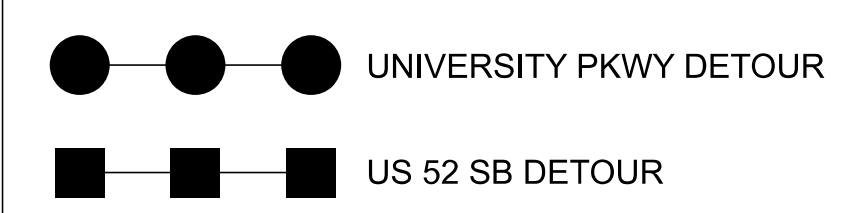

APPROVED: *Kenneth C. Thomwell Jr., P.E.*
 DATE: 03/06/2026

SEAL

DOCUMENT NOT CONSIDERED FINAL UNLESS ALL SIGNATURES COMPLETED

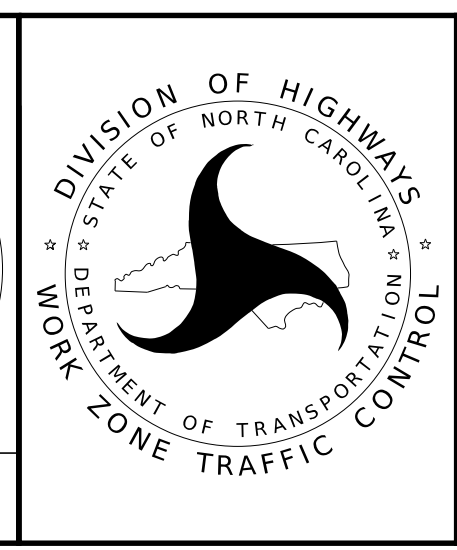

US 52 NORTH RAMP CLOSURES (30 DAYS)

2/10/2026 pw:/ncdot-pw.bentley.com:ncdot-pw-01/Documents/Division_09/BR-0168/Work Zone Traffic Control/BR-0168-TC-TMP-02F-Detour NB Ramps User:jbeaver1

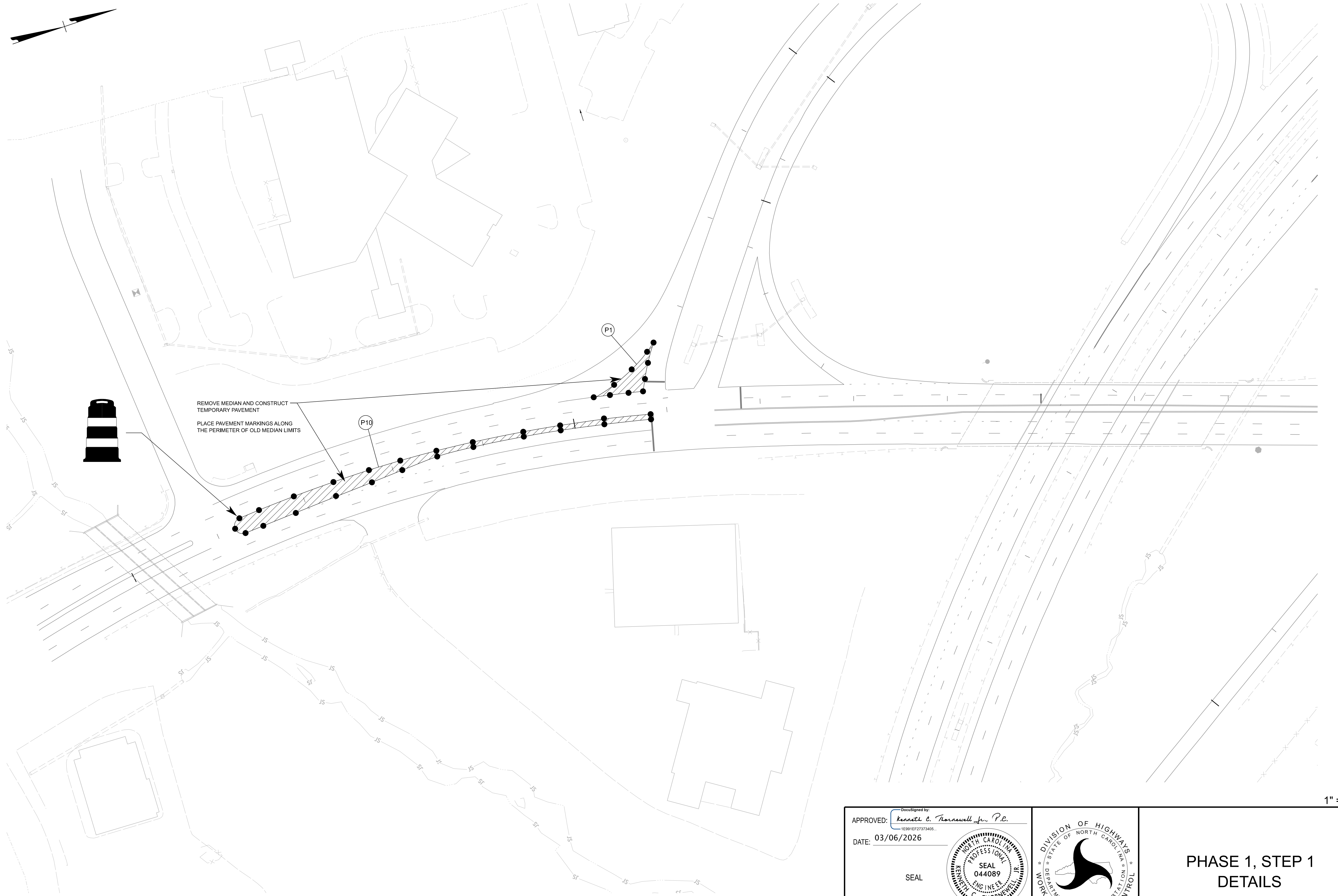
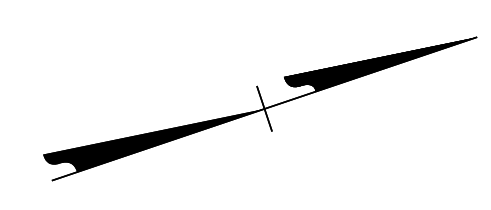

2/10/2026
 pw:/ncdot-pw.bentley.com:ncdot-pw-01/Documents/Division_09/BR-0168/Work Zone Traffic Control/BR-0168-TC-TMP-03.1-Phase 1 Step 1 Details (1)
 User:jdbeaver1

1" = 50'

APPROVED: *Kenneth C. Thornwell Jr., P.E.*
1E991EF27373405

DATE: 03/06/2026

SEAL

**DOCUMENT NOT CONSIDERED FINAL
UNLESS ALL SIGNATURES COMPLETED**

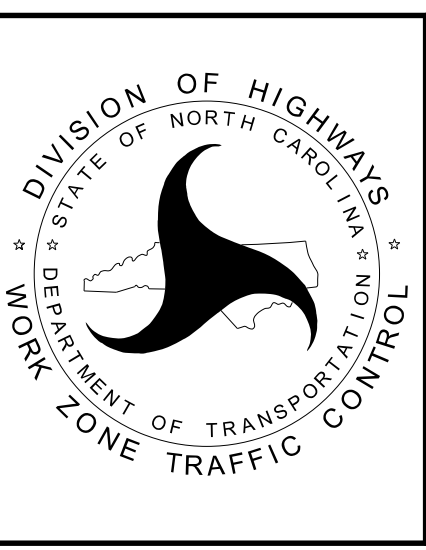

PHASE 1, STEP 1
 DETAILS

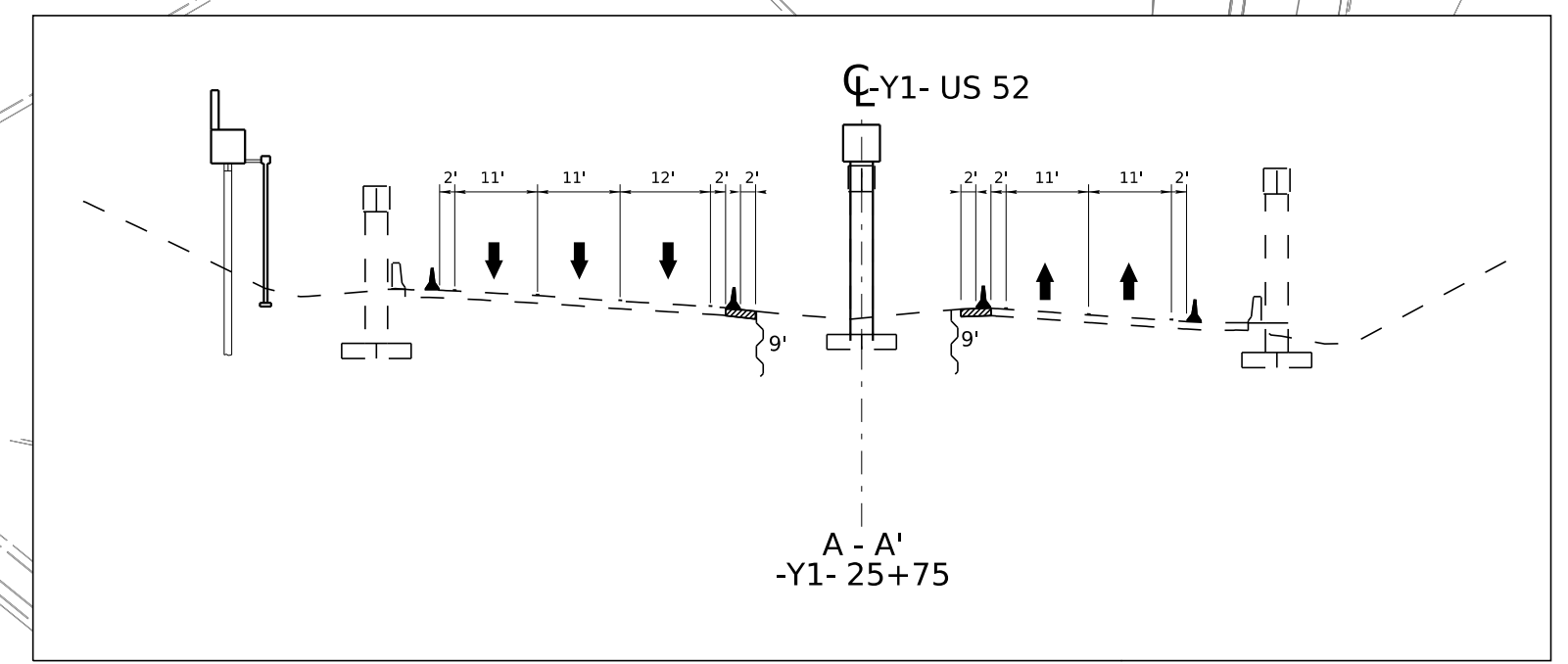
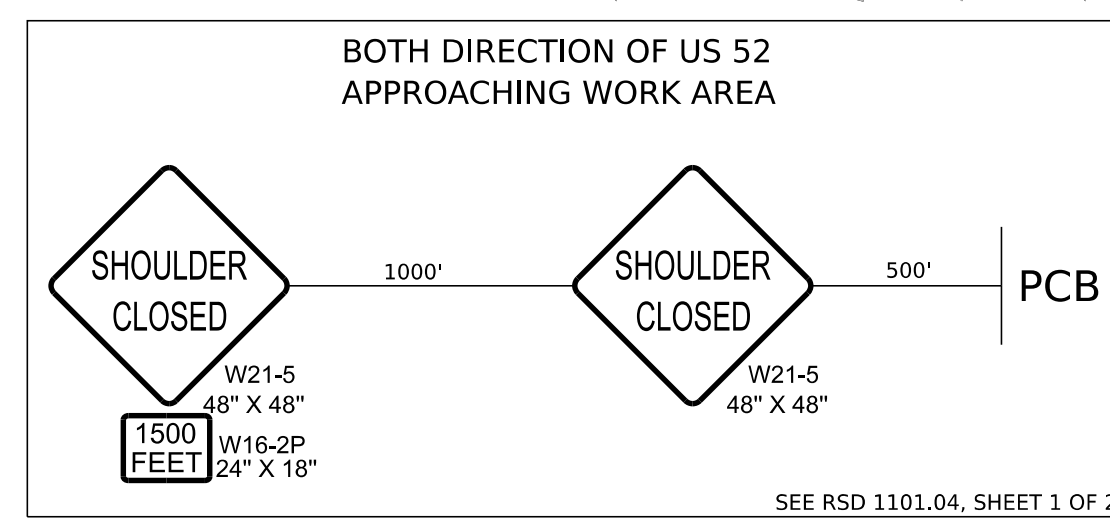
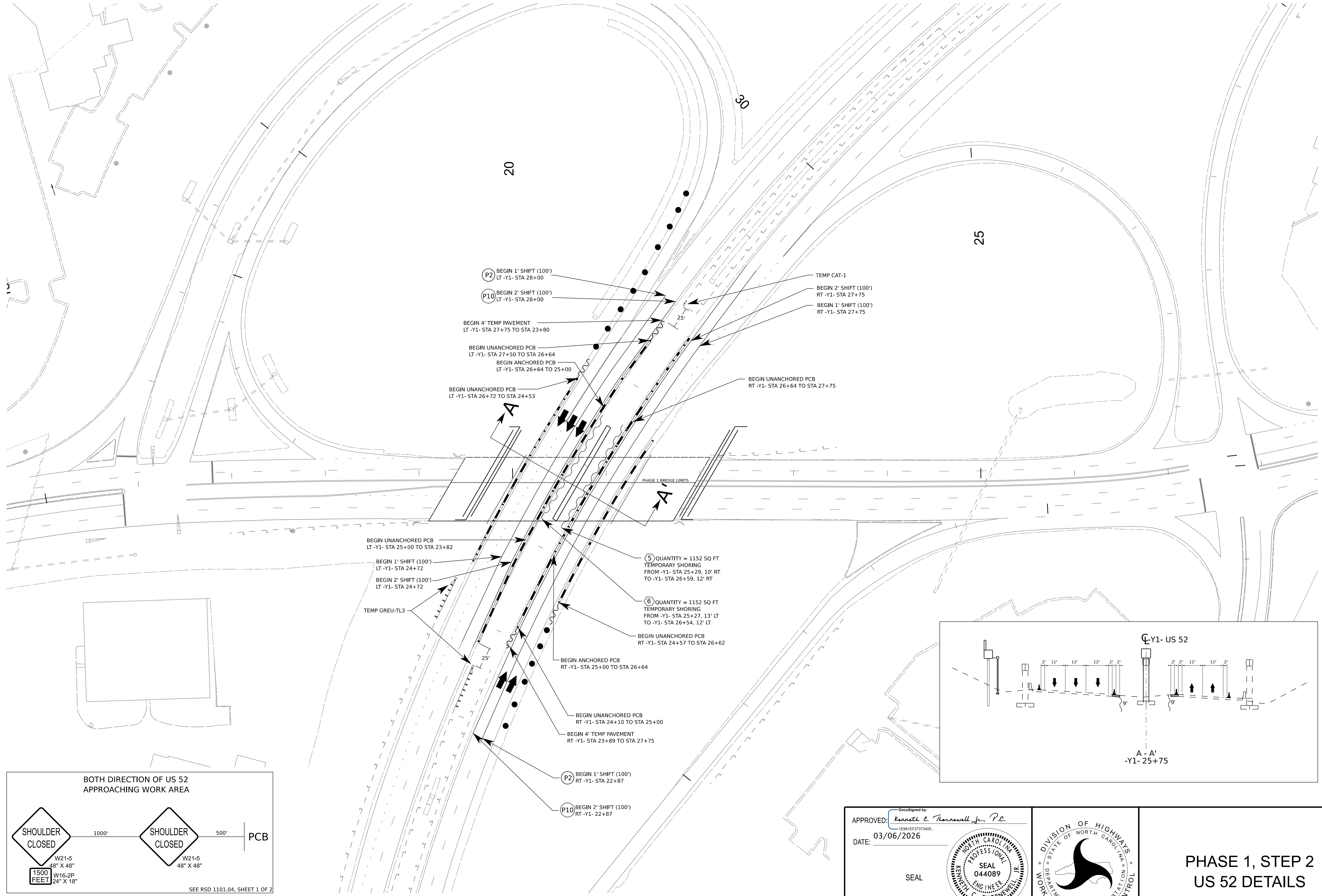

1" = 50'

APPROVED: *Kenneth C. Horne III, P.E.*
 DATE: 03/06/2026

SEAL

DOCUMENT NOT CONSIDERED FINAL
 UNLESS ALL SIGNATURES COMPLETED

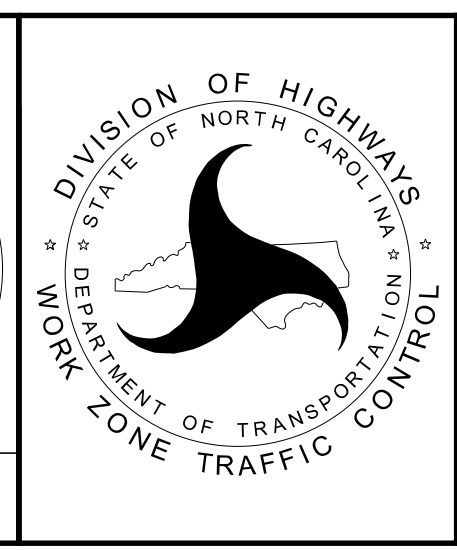

PHASE 1, STEP 2
 US 52 DETAILS

3/6/2026 pw/mcdol-pw.bentley.com:mcdol-pw-01/Documents/Division_09/BR-0168/Work Zone Traffic Control/BR-0168-TC-TMP-03.2-Phase 1 Step 2 US52 User:jdbeaver1

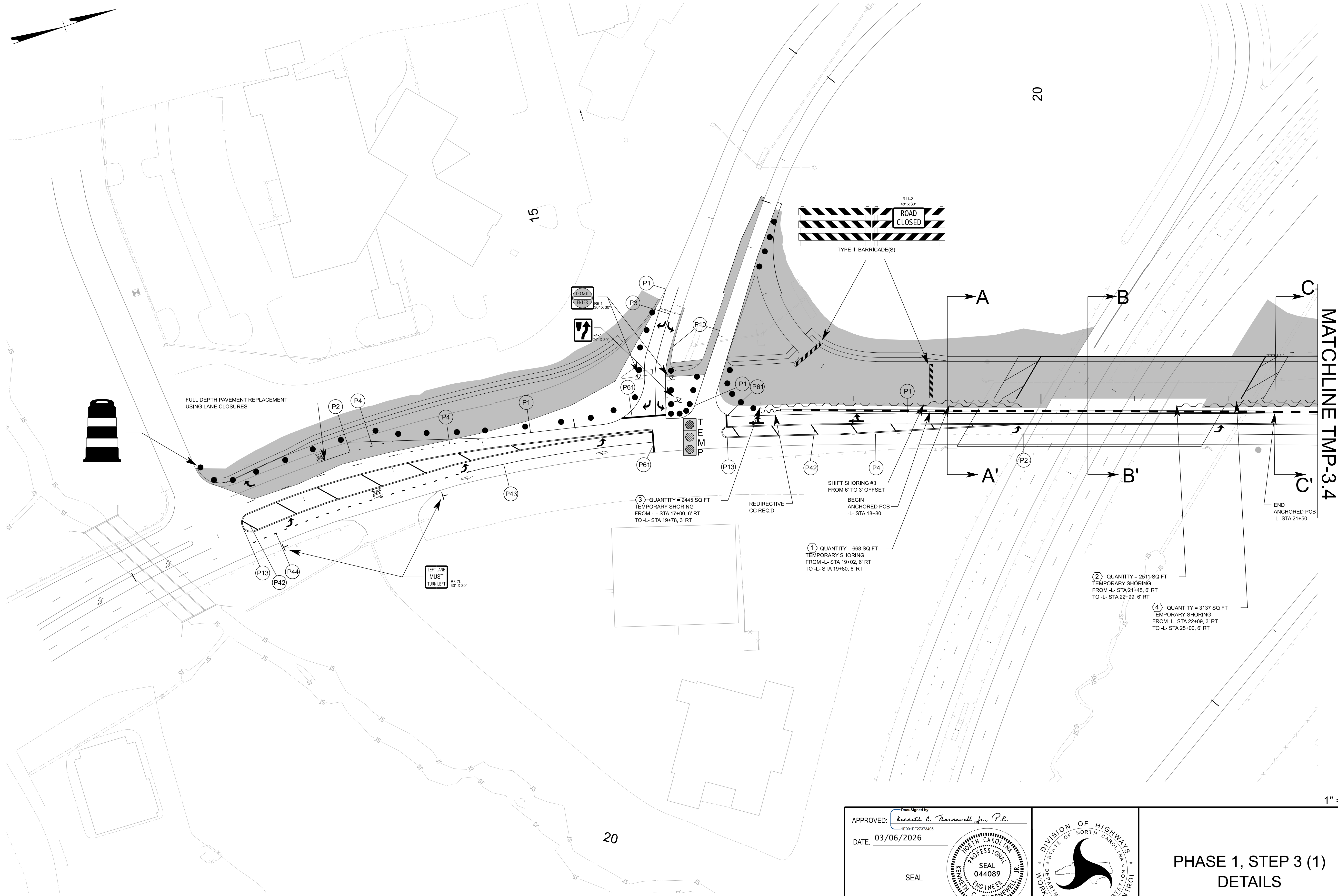

2/11/2026 pw:/ncdot-pw/bentley.com:ncdot-pw-01/Documents/Division_09/BR-0168/Work Zone Traffic Control/BR-0168-TC-TMP-03.3-Phase 1 Step 3 (1) User:jdbeaver1

1" = 50'

APPROVED: *Kenneth C. Thornwell Jr., P.E.*
 DATE: 03/06/2026

SEAL

DOCUMENT NOT CONSIDERED FINAL UNLESS ALL SIGNATURES COMPLETED

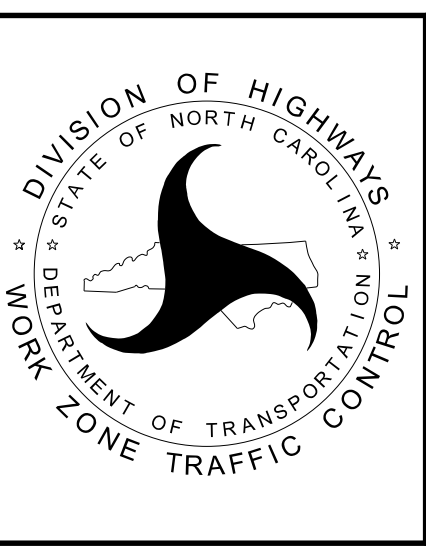

PHASE 1, STEP 3 (1) DETAILS

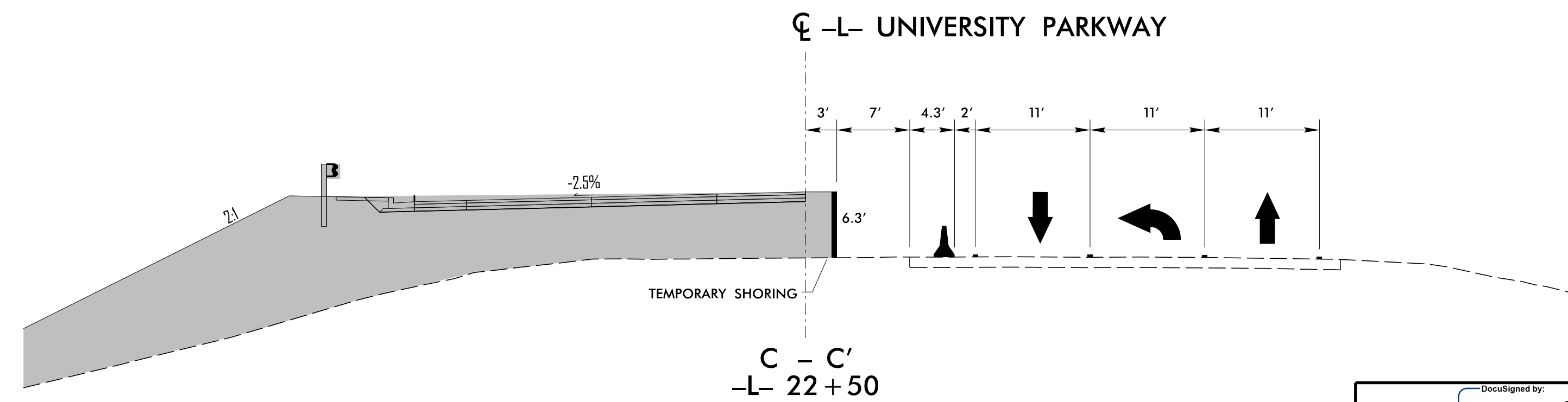
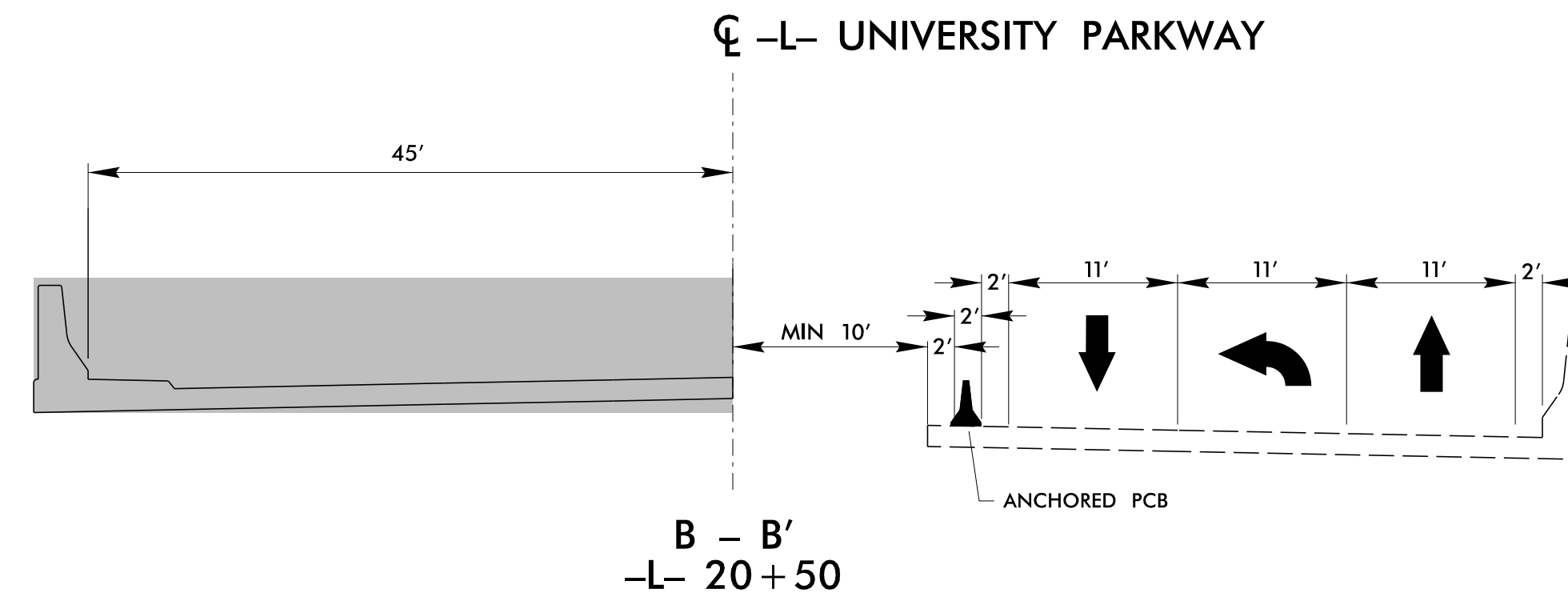
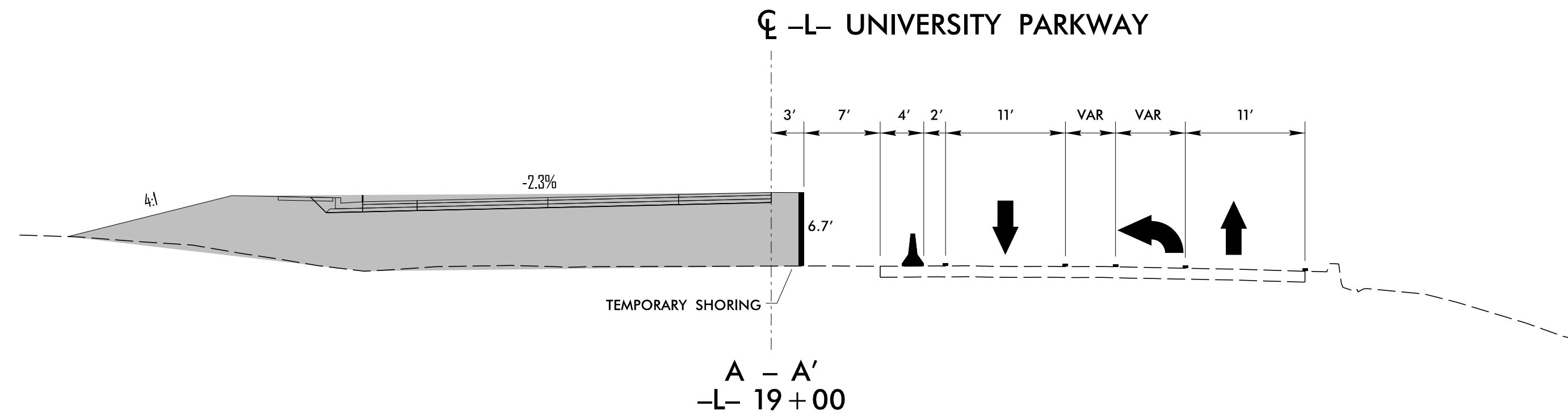

2/10/2026
pw:/ncdot-pw.bentley.com:ncdot-pw-01/Documents/Division_09/BR-0168/Work Zone Traffic Control/BR-0168-TC-TMP-03.3A-Phase 1 Step 3 (1) XS
User:jdbeaver1

APPROVED: *Kenneth C. Hornswell Jr., P.E.*
DATE: 03/06/2026

SEAL

**DOCUMENT NOT CONSIDERED FINAL
UNLESS ALL SIGNATURES COMPLETED**

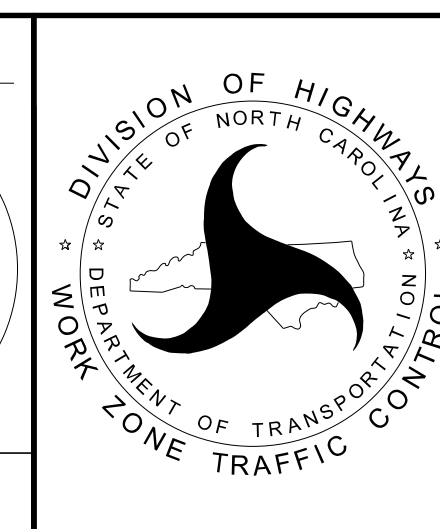

PHASE 1, STEP 3 (1)
XS

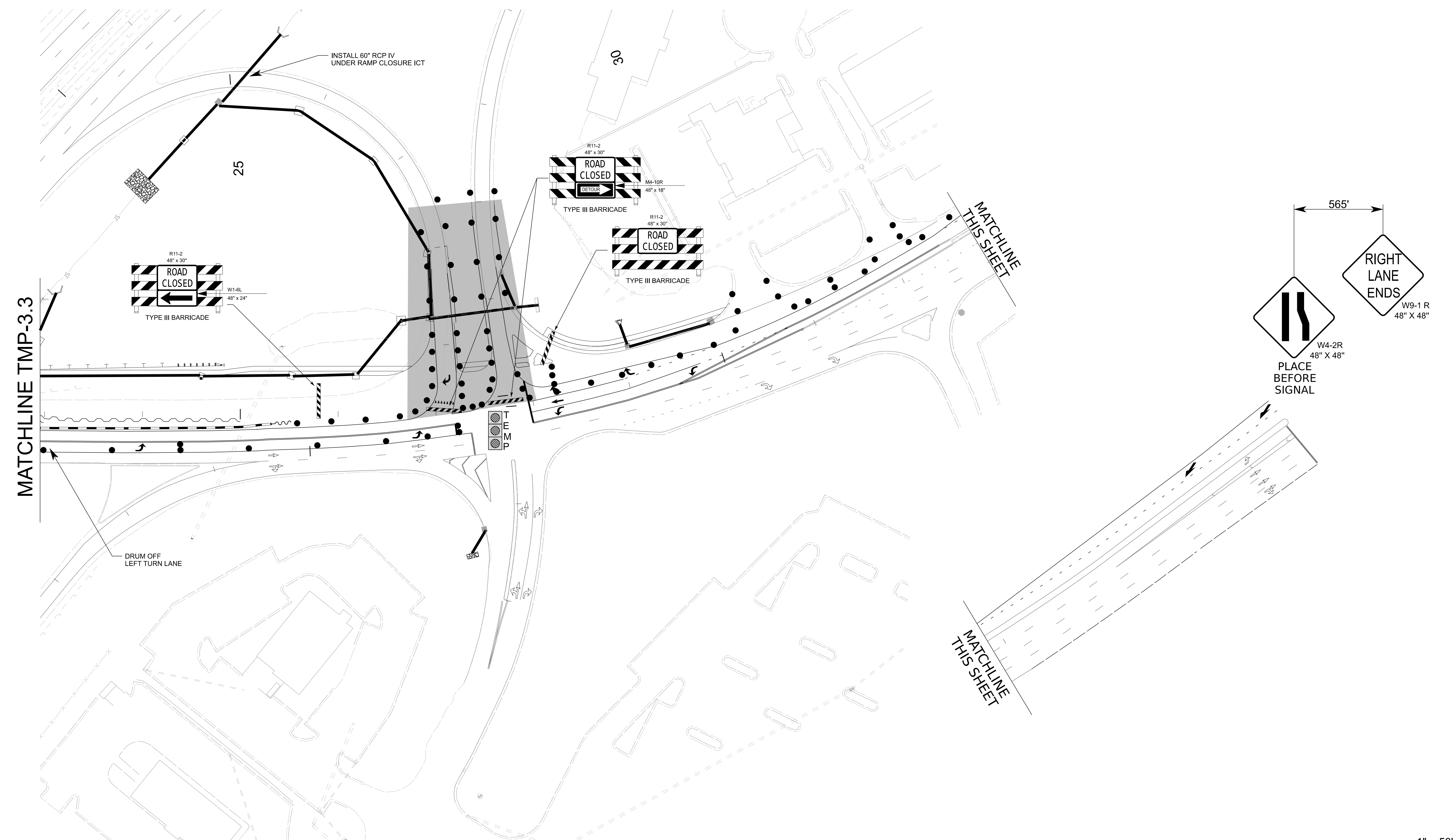

3/6/2026
 pwr/mcdot-pw.bentley.com:mcdot-pw-01/Documents/Division_09/BR-0168/Work Zone Traffic Control/BR-0168-TC-TMP-03.6-Phase 1 Step 6
 User:jdbeaver1

1" = 50'

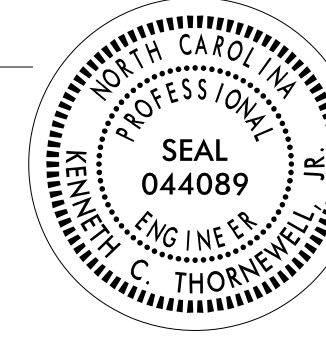
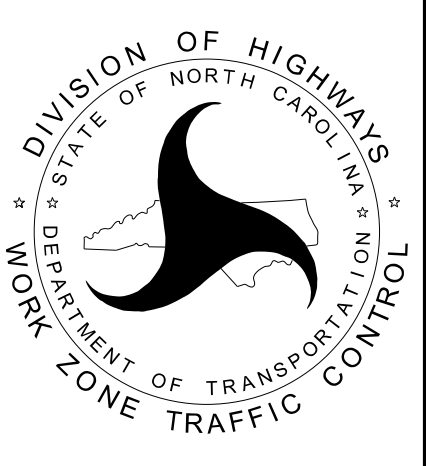
<p>APPROVED: <i>Kenneth C. Thornewell, Jr., P.E.</i> <small>1E091EF27373405</small></p> <p>DATE: 03/06/2026</p> <p>SEAL</p> 		<p>PHASE 1, STEP 6 (30-DAY ICT)</p>
<p>DOCUMENT NOT CONSIDERED FINAL UNLESS ALL SIGNATURES COMPLETED</p>		

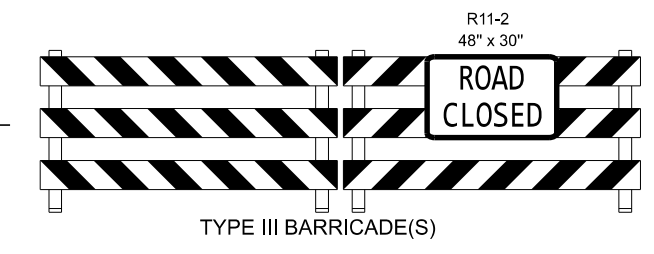
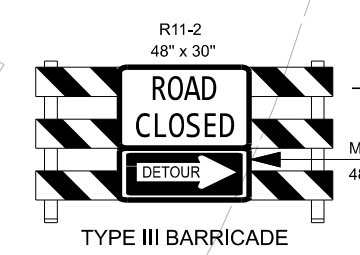
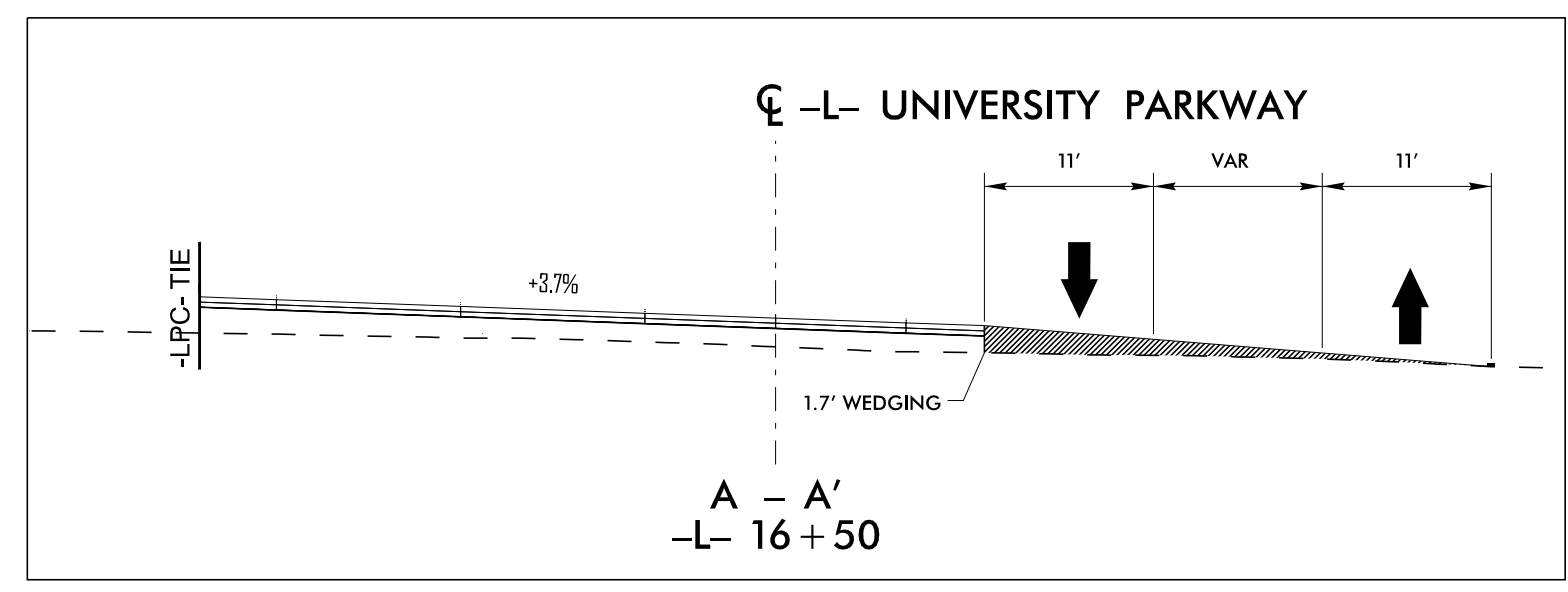
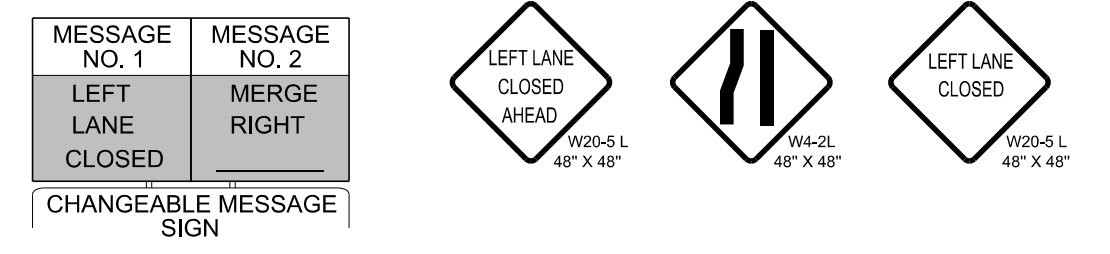
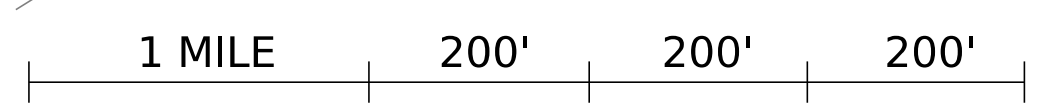
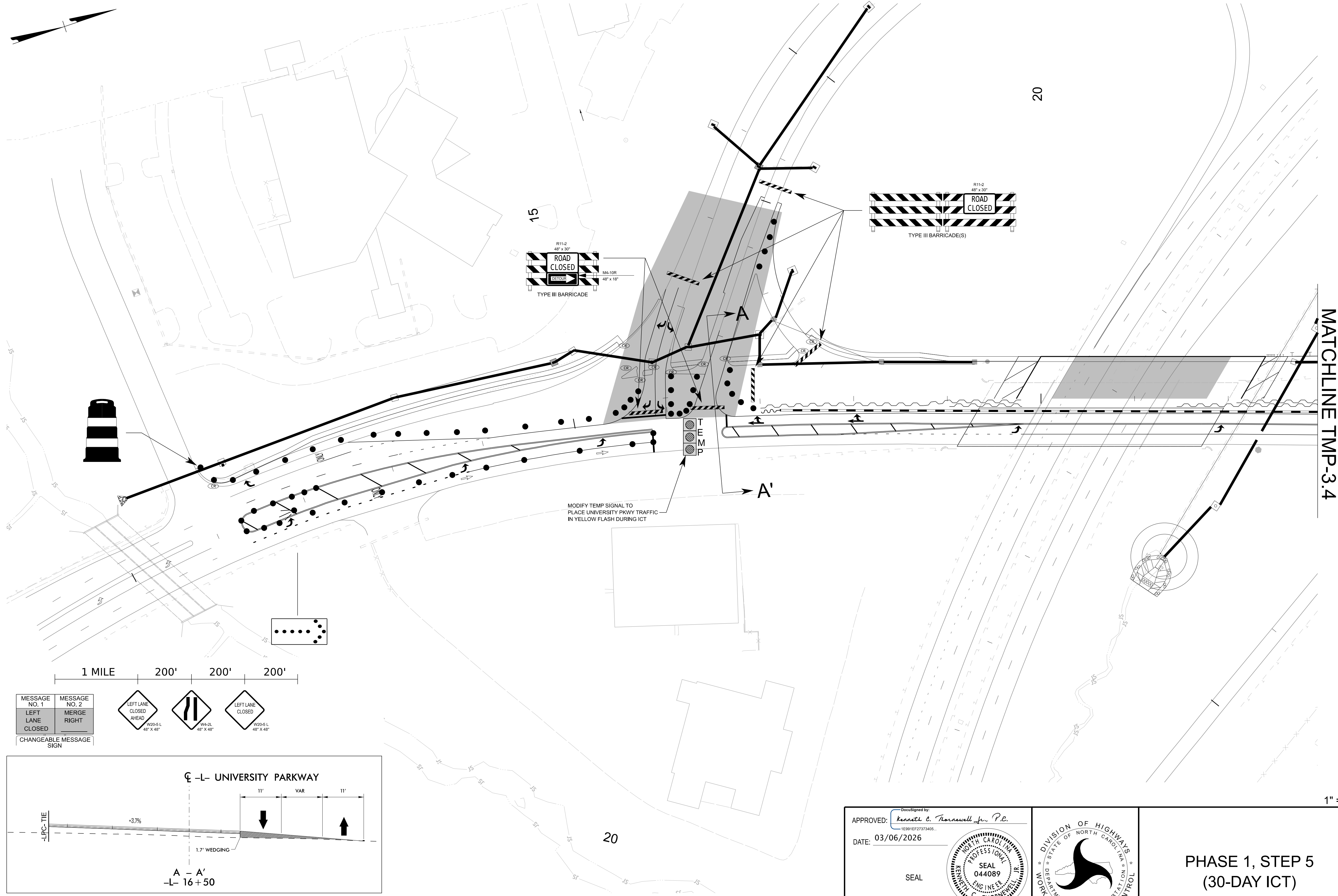

MODIFY TEMP SIGNAL TO PLACE UNIVERSITY PKWY TRAFFIC IN YELLOW FLASH DURING ICT

MATCHLINE TMP-3.4

1" = 50'

APPROVED: *Kenneth C. Thomwell Jr., P.E.*
 DATE: 03/06/2026

SEAL

DOCUMENT NOT CONSIDERED FINAL UNLESS ALL SIGNATURES COMPLETED

**PHASE 1, STEP 5
(30-DAY ICT)**

3/4/2026 pwr/mcdol-pw.bentley.com:ncdol-pw-01/Documents/Division_09/BR-0168/Work Zone Traffic Control/BR-0168-TC-TMP-03.5-Phase 1 Step 5 User:jdbeaver1

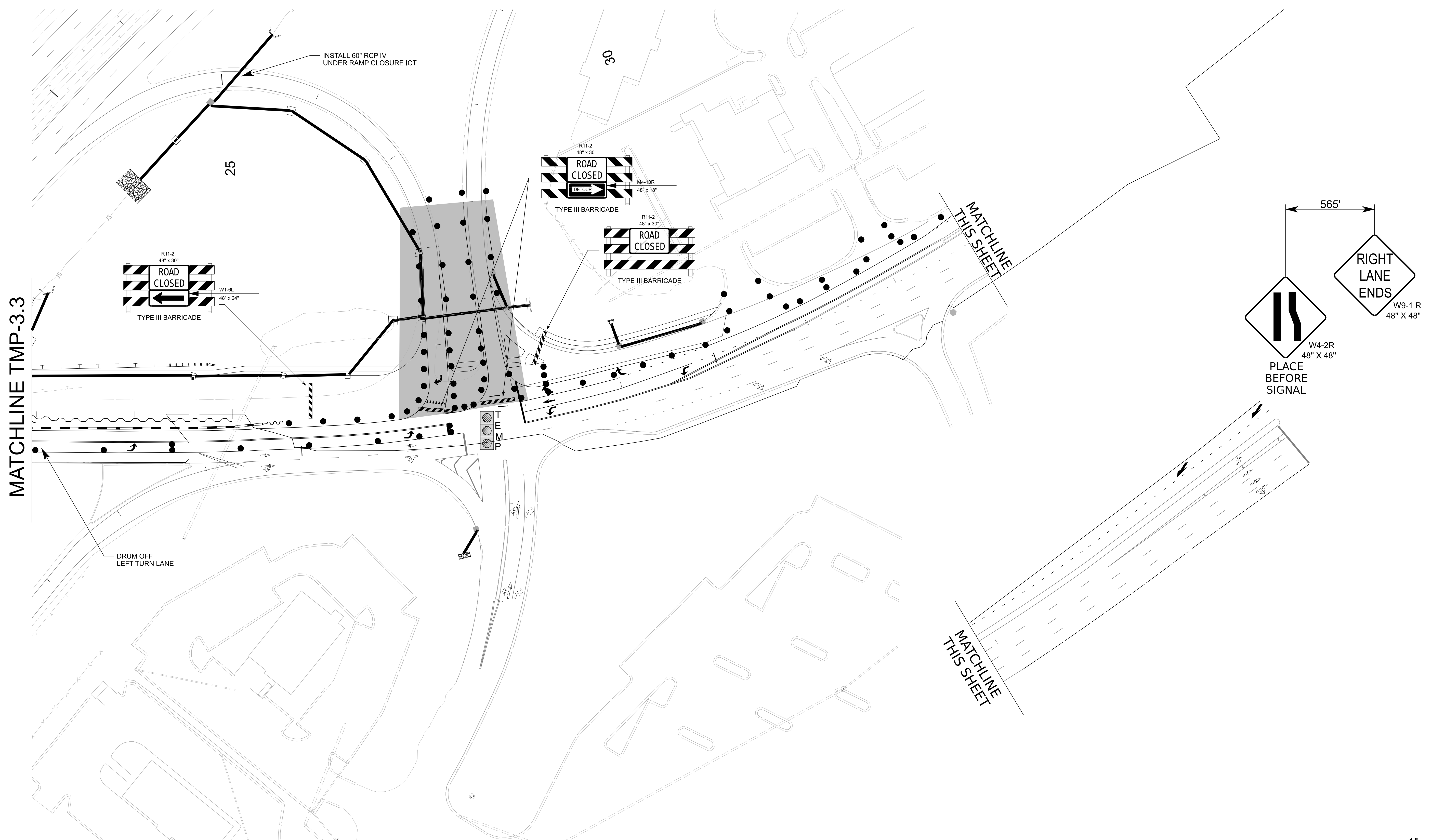

MATCHLINE TMP-3.3

MATCHLINE THIS SHEET

MATCHLINE THIS SHEET

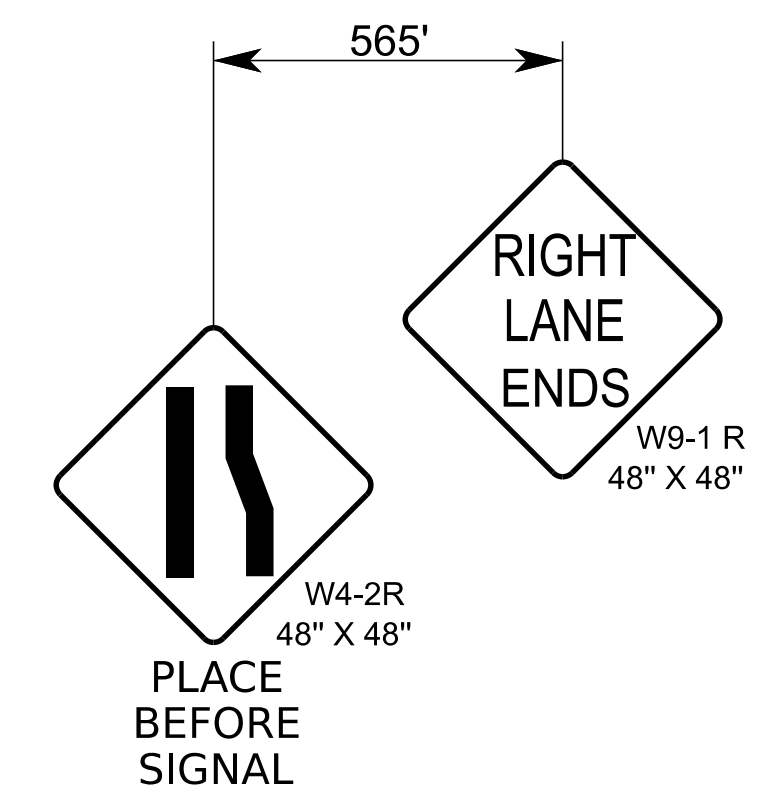

2/11/2026
pw:/ncdot-pw.bentley.com:ncdot-pw-01/Documents/Division_09/BR-0168/Work Zone Traffic Control/BR-0168-TC-TMP-03.6-Phase 1 Step 6
User:jdbeaver1

1" = 50'

APPROVED: *Kenneth C. Thornwell Jr., P.E.*
1E991EF27373405

DATE: 03/06/2026

SEAL

**PHASE 1, STEP 6
(30-DAY ICT)**

**DOCUMENT NOT CONSIDERED FINAL
UNLESS ALL SIGNATURES COMPLETED**

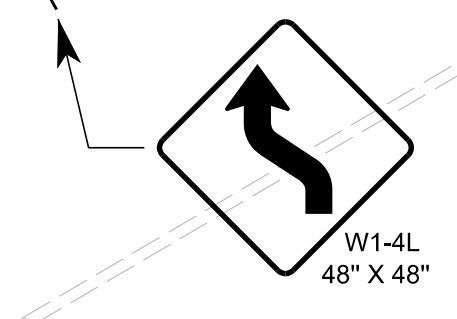
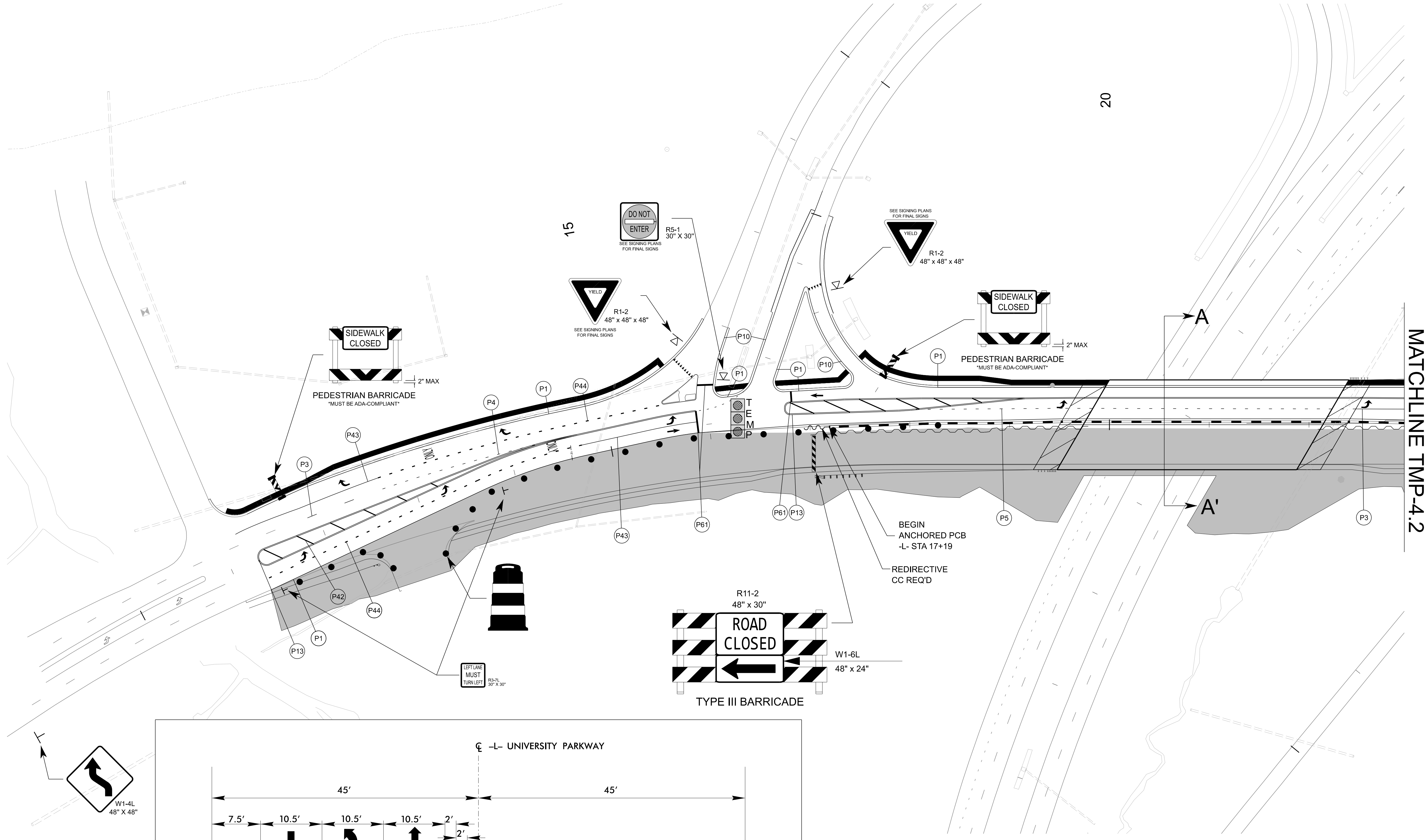

MATCHLINE TMP-4.2

1" = 50'

2/11/2026
pw:/ncdot-pw.bentley.com:ncdot-pw-01/Documents/Division_09/BR-0168/Work Zone Traffic Control/BR-0168-TC-TMP-04.1-Phase 2 Step 1 (1)
User:jdbeaver1

APPROVED: *Kenneth C. Thomwell Jr., P.E.*
DATE: 03/06/2026

SEAL

**DOCUMENT NOT CONSIDERED FINAL
UNLESS ALL SIGNATURES COMPLETED**

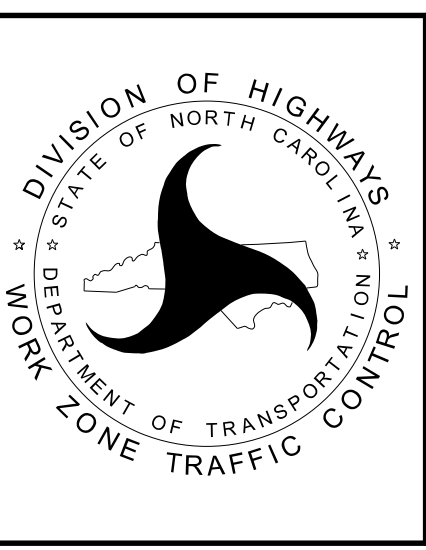

**PHASE 2, STEP 1 (1)
DETAILS**

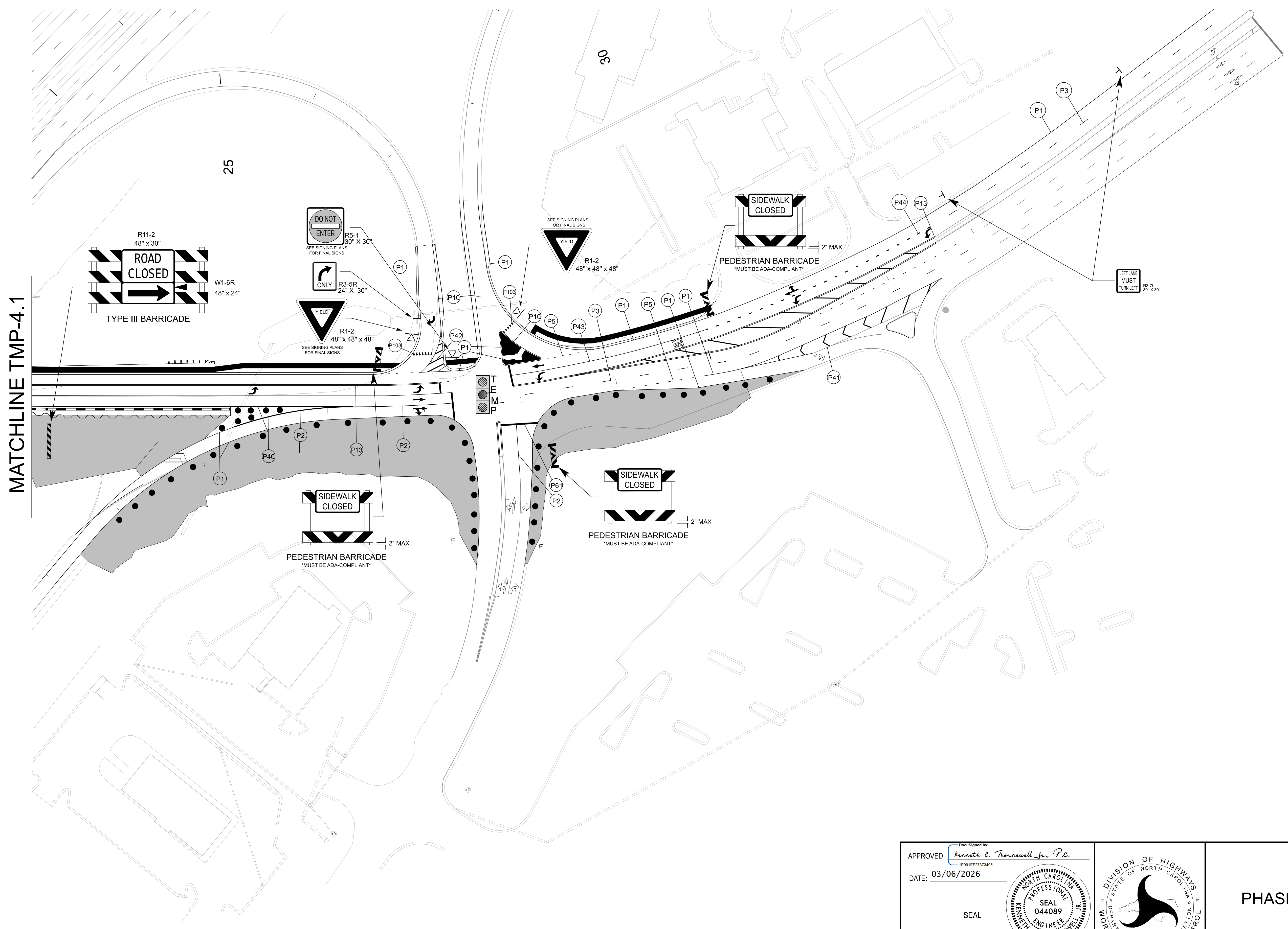

2/11/2026
 pw:/ncdot-pw.bentley.com:ncdot-pw-01/Documents/Division_09/BR-0168/Work Zone Traffic Control/BR-0168-TC-TMP-04.2-Phase 2 Step 1 (2)
 User:jdbeaver1

1" = 50'

APPROVED: *Kenneth C. Thornwell Jr., P.E.*
 DATE: 03/06/2026

SEAL

**DOCUMENT NOT CONSIDERED FINAL
UNLESS ALL SIGNATURES COMPLETED**

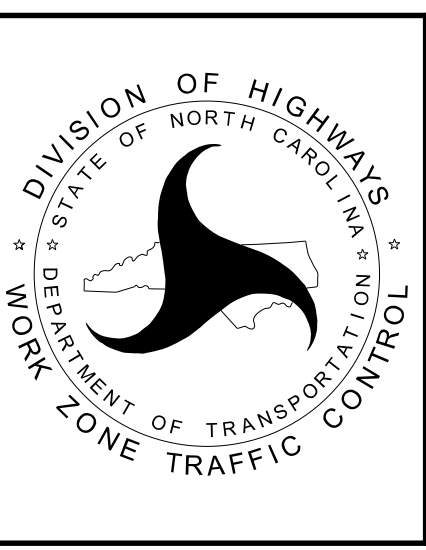

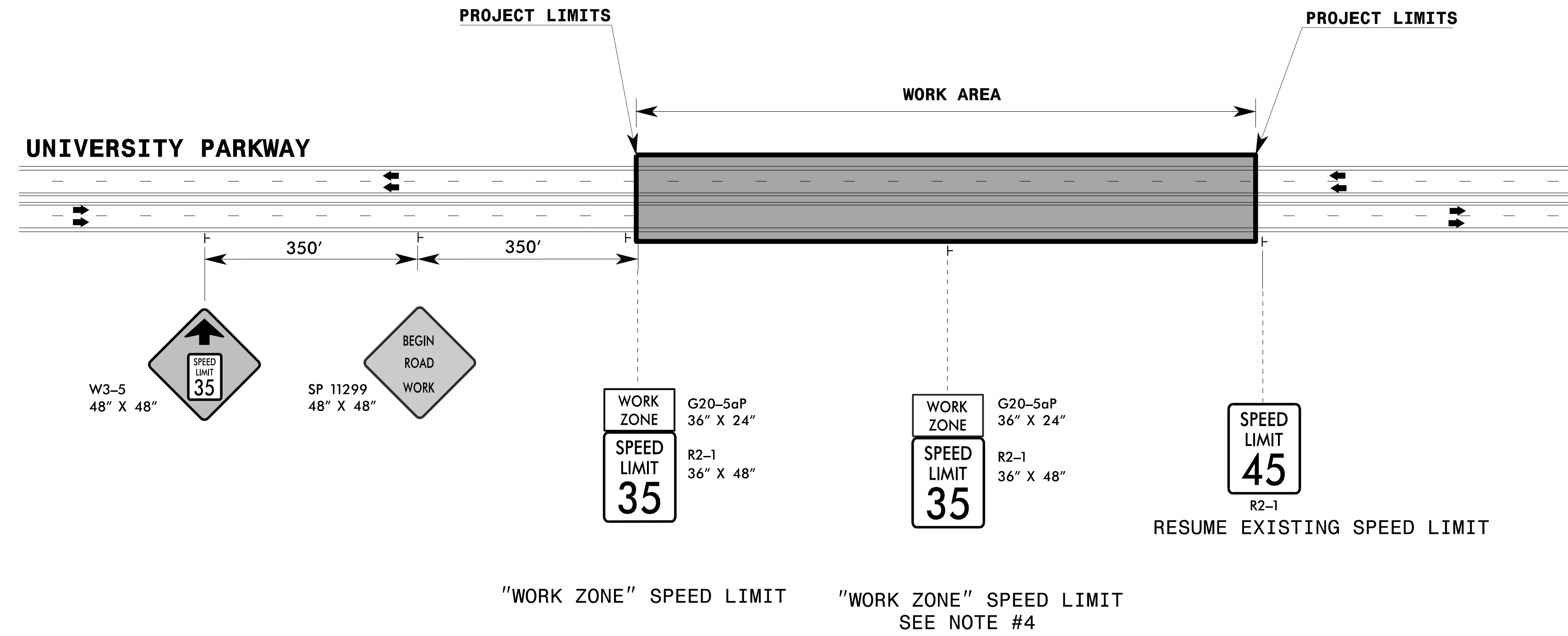

**PHASE 2, STEP 1 (2)
 DETAILS**



NOTES

- 1) THE WORK ZONE SPEED LIMIT WILL BE ESTABLISHED IN COLLABORATION BETWEEN THE REGIONAL TRAFFIC ENGINEER, THE DIVISION AND THE WORK ZONE TRAFFIC CONTROL SECTION. THIS DRAWING SHOWS THE TYPICAL APPLICATION OF REDUCING THE "WORK ZONE SPEED LIMIT" TO 35 MPH.

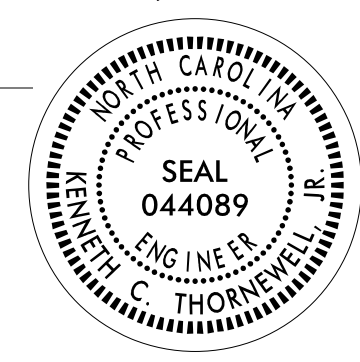
2/10/2026
pw:/ncdot-pw.bentley.com:ncdot-pw-01/Documents/Division_09/BR-0168/Work Zone Traffic Control/BR-0168-TC-TMP-05.1-Static WZ Speed Reduction
User: jbeaver1

APPROVED: <i>Kenneth C. Thornwell Jr., P.E.</i> <small>1E991EF27373405</small> DATE: 03/06/2026 SEAL			STATIC WZ SPEED REDUCTION UNIVERSITY PKWY
<small>DOCUMENT NOT CONSIDERED FINAL UNLESS ALL SIGNATURES COMPLETED</small>			

COORDINATE WITH C204837, U-2729 (HANES MILL ROAD) ON OVERLAPPING DEVICES

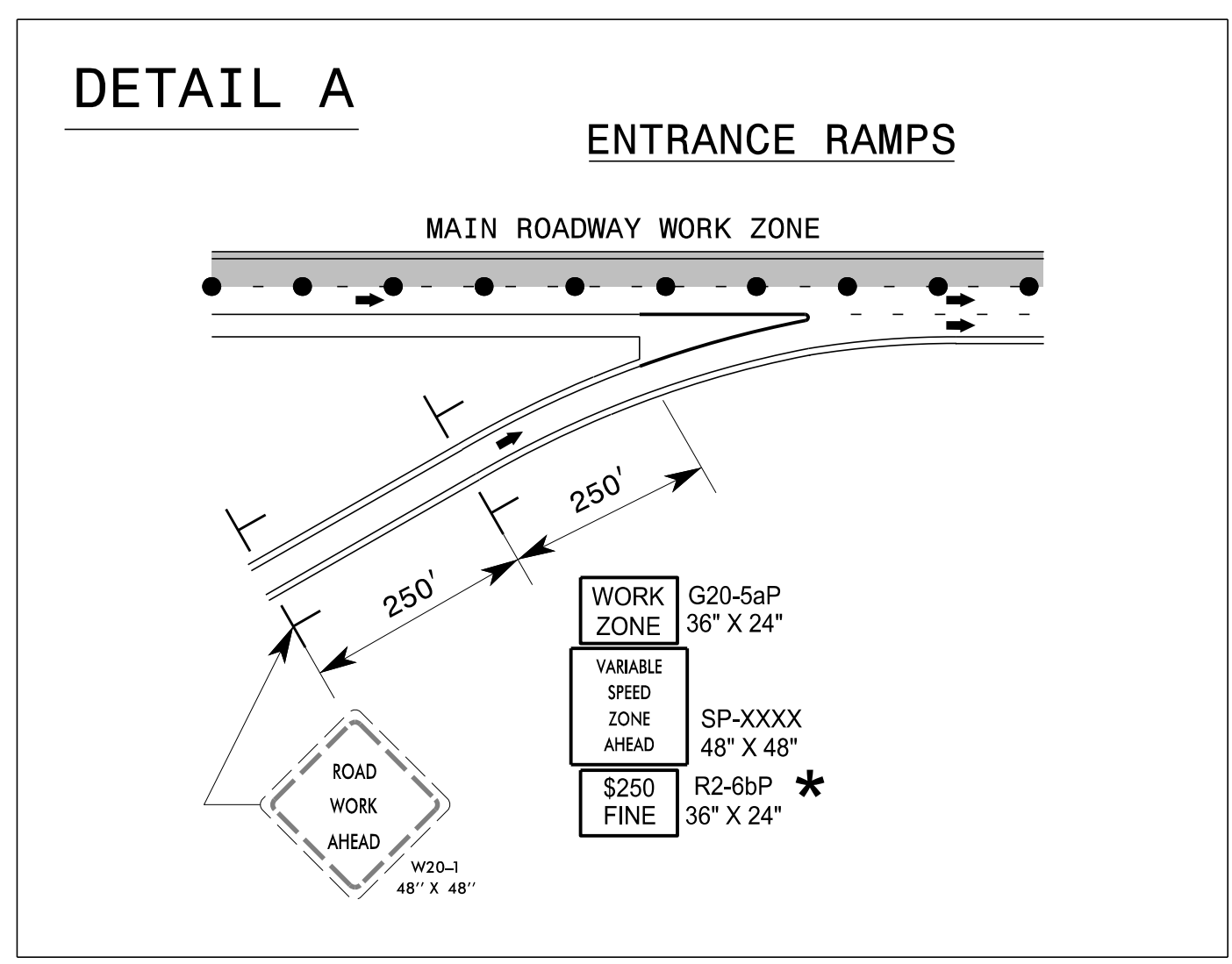
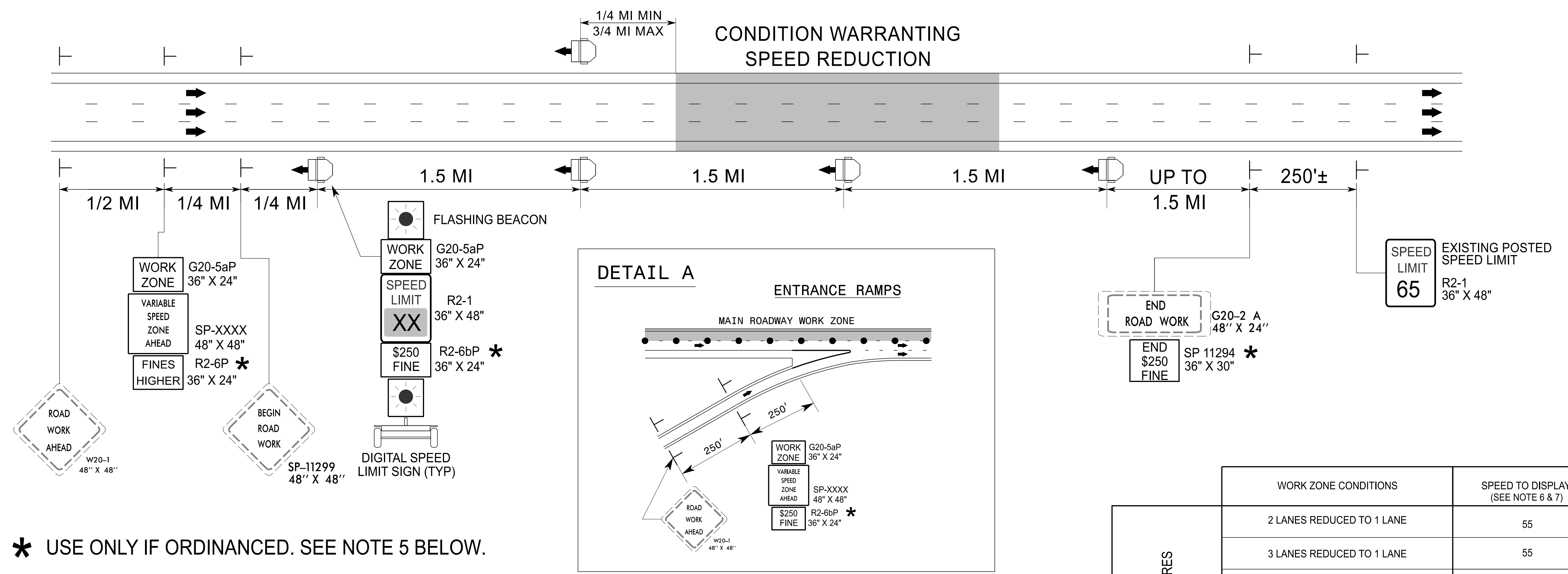

* USE ONLY IF ORDINANCED. SEE NOTE 5 BELOW.

NOTES

1. THE DIGITAL SPEED LIMITS SIGNS WILL BE INSTALLED (TRAILER MOUNTED OR STATIONARY MOUNTED) IN ADVANCE OF AND SPACED APPROXIMATELY 1.5 MILES THROUGHOUT THE THE PROJECT LIMITS, UNLESS DIRECTED OTHERWISE.
2. WITHIN 1/4 TO 3/4 MILE UPSTREAM OF CONDITION WARRANTING A SPEED REDUCTION, PLACE A DIGITAL SPEED LIMIT SIGN ON BOTH THE INSIDE AND OUTSIDE SHOULDERS, UNLESS DIRECTED OTHERWISE BY THE ENGINEER. AT ALL OTHER LOCATIONS DOWNSTREAM, PLACE A SINGLE DIGITAL SPEED LIMIT SIGN ON THE OUTSIDE SHOULDER.

IF SIGNS ARE NOT HIGHLY VISIBLE TO ALL MOTORISTS, SUPPLEMENTAL DIGITAL SPEED LIMIT SIGNS ARE PERMITTED ON THE MEDIAN SHOULDER.
3. THE DIGITAL SPEED LIMIT SIGNS TAKE PRECEDENCE OVER EXISTING SPEED LIMIT SIGNS AND SHOULD REMAIN UPRIGHT AND VISIBLE AT ALL TIMES. ALL EXISTING SPEED LIMIT SIGNS SHALL BE COVERED OR REMOVED FOR DURATION OF THE PROJECT.
4. NCDOT HAS SOLE AUTHORITY OF THE SPEED LIMITS DISPLAYED ON THE DIGITAL SPEED LIMIT SIGNS.
5. THE WORK ZONE VARIABLE SPEED LIMIT AND THE \$250 SPEEDING PENALTY ARE SEPARATE ORDINANCES THAT MUST BE SIGNED BY THE STATE TRAFFIC ENGINEER TO BE VALID AND ENFORCEABLE. WITHOUT SIGNED ORDINANCES, THE SPEED LIMIT ON A FACILITY SHALL REMAIN UNCHANGED AND/OR HIGHER FINES SIGNS SHALL NOT BE USED.
6. THE REDUCED SPEED SHALL BE DISPLAYED A MINIMUM OF 1/4 MILE AND A MAXIMUM OF 3/4 MILE IN ADVANCE OF AND THROUGHOUT THE AREA MEETING CONDITIONS LISTED IN THE CHART. THE EXISTING SPEED LIMIT SHALL BE DISPLAYED ON ALL OTHER DIGITAL SPEED LIMIT SIGNS.
7. THE SPEED DISPLAYED SHALL BE THE LOWER OF THE EXISTING SPEED LIMIT OR THE SPEED IN THE WORK ZONE CONDITION CHART.
8. THE BEACONS ON THE DIGITAL SPEED LIMIT SIGNS SHALL ONLY FLASH DURING TIMES THE SPEED IS REDUCED, AND REMAIN OFF AT ALL OTHER TIMES.

	WORK ZONE CONDITIONS	SPEED TO DISPLAY (SEE NOTE 6 & 7)
LANE CLOSURES	2 LANES REDUCED TO 1 LANE	55
	3 LANES REDUCED TO 1 LANE	55
	3 LANES REDUCED TO 2 LANES	60
	4 LANES REDUCED TO 1 LANE	55
	4 LANES REDUCED TO 2 LANES	60
	4 LANES REDUCED TO 3 LANES	65
CONTINUOUS BARRIER (LENGTH OF BARRIER GREATER THAN 1 MILE)	1 OPEN LANE WITH CONTINUOUS BARRIER ON BOTH SHOULDERS	55
	1 OPEN LANE WITH CONTINUOUS BARRIER ON 1 SHOULDER	60
	3 OR 2 OPEN LANES WITH CONTINUOUS BARRIER ON BOTH SHOULDERS	60
	3 OR 2 OPEN LANES WITH CONTINUOUS BARRIER ON 1 SHOULDER	65
	4 OPEN LANES WITH BARRIER CONTINUOUS ON BOTH SHOULDERS	65
	4 OPEN LANES WITH BARRIER CONTINUOUS ON 1 SHOULDER	EXISTING
	UNEVEN LANES	60

APPROVED: *Kenneth C. Hornswell Jr., P.E.*
 DATE: 03/06/2026
 SEAL
 DOCUMENT NOT CONSIDERED FINAL UNLESS ALL SIGNATURES COMPLETED

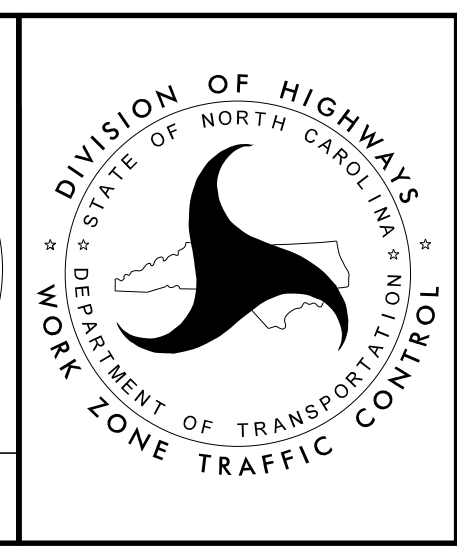

WORK ZONE VARIABLE SPEED LIMIT REDUCTION (US-52)

2/10/2026 pw://ncdot-pw.bentley.com/ncdot-pw-0/Document/Division_09/BR-0168/Work Zone Traffic Control/BR-0168-TC-TMP-05.2-Variable WZ Speed Reduction User:jdbeaver1