

PAVEMENT SCHEDULE

C1	1.5" TYPE S9.5C
C2	3" TYPE S9.5C
C3	1.5" TYPE S9.5D
C4	3" TYPE S9.5D
D1	3.5" TYPE I19.0C
D2	4" TYPE I19.0C
E1	4" TYPE B25.0C
E2	11" TYPE B25.0C
J1	6" ABC
K	SUBGRADE STABILIZATION
N	GEOTEXTILE
P	PRIME COAT
R1	2'-6" C&G
R2	5" CONC. ISLAND (KEYED IN)
R3	SHOULDER BERM GUTTER
T	EARTH MATERIAL
U	EXISTING ASPHALT PVMT
V1	INC. MILLING
V2	1.5" MILLING
W	WEDGING
Y	RUMBLE STRIPS

NOTE: PAVEMENT EDGE SLOPES ARE 1:1 UNLESS SHOWN OTHERWISE

NOTES: SEE PLANS FOR LOCATIONS OF AUXILIARY LANES AND TAPERS

SEE SHEET 2A-1 FOR DETAIL SHOWING PLACEMENT OF CHEMICAL STABILIZATION-GEOTEXTILE FOR SUBGRADE STABILIZATION FOR PAVEMENT WITH ABC

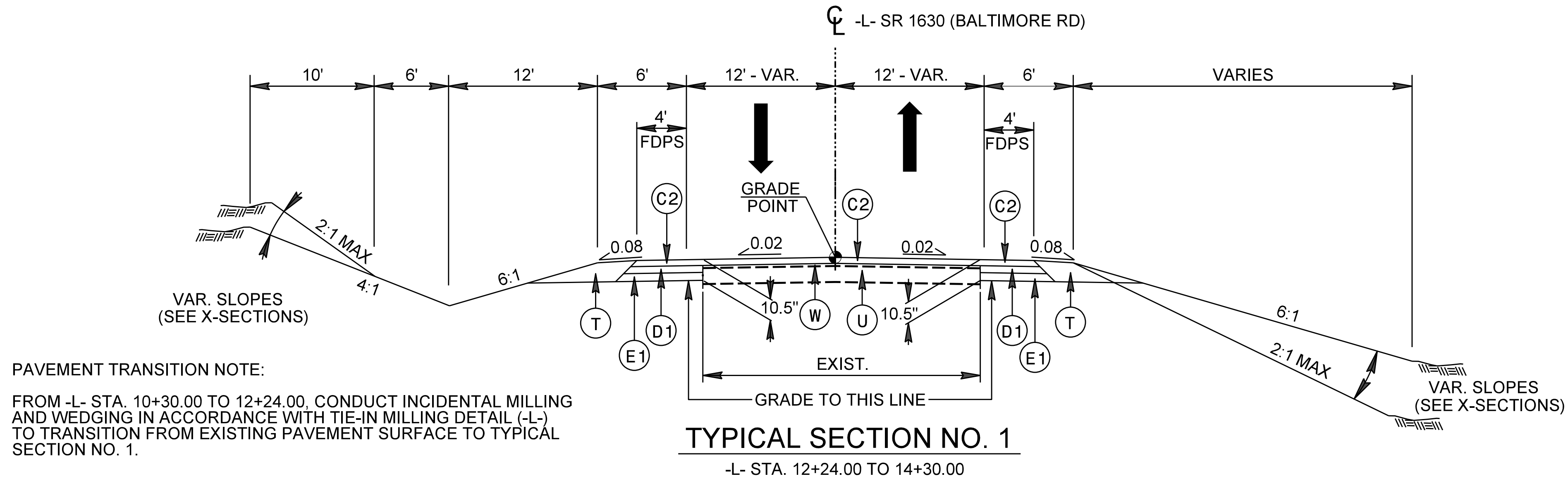

PAVEMENT TRANSITION NOTE:

FROM -L- STA. 10+30.00 TO 12+24.00, CONDUCT INCIDENTAL MILLING AND WEDGING IN ACCORDANCE WITH TIE-IN MILLING DETAIL (-L-) TO TRANSITION FROM EXISTING PAVEMENT SURFACE TO TYPICAL SECTION NO. 1.

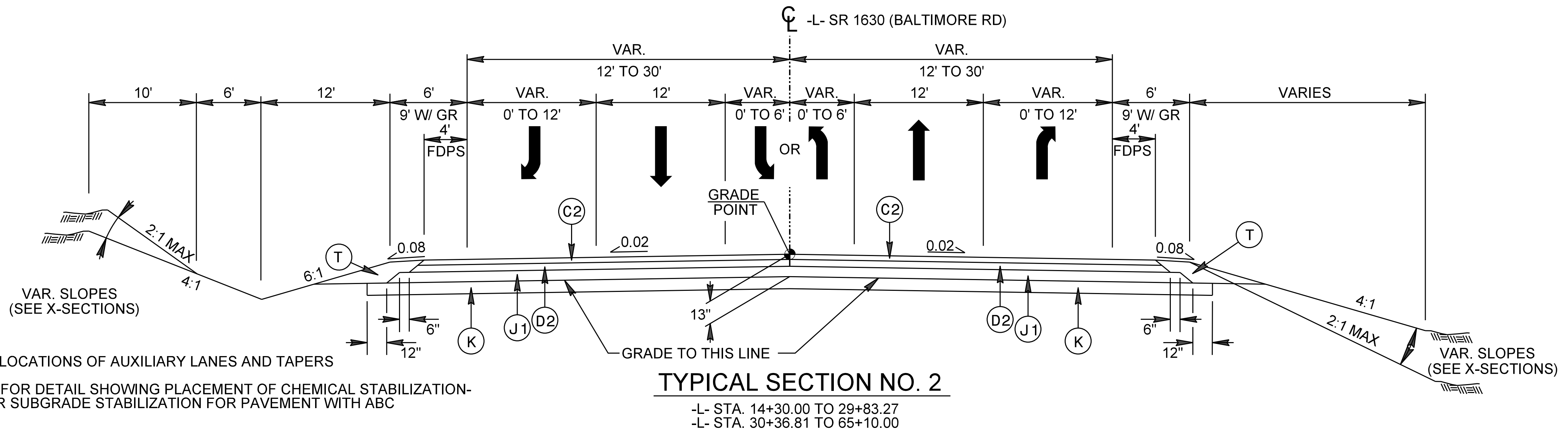

INSET "A"
SHOULDER BERM GUTTER DETAIL (SBG)

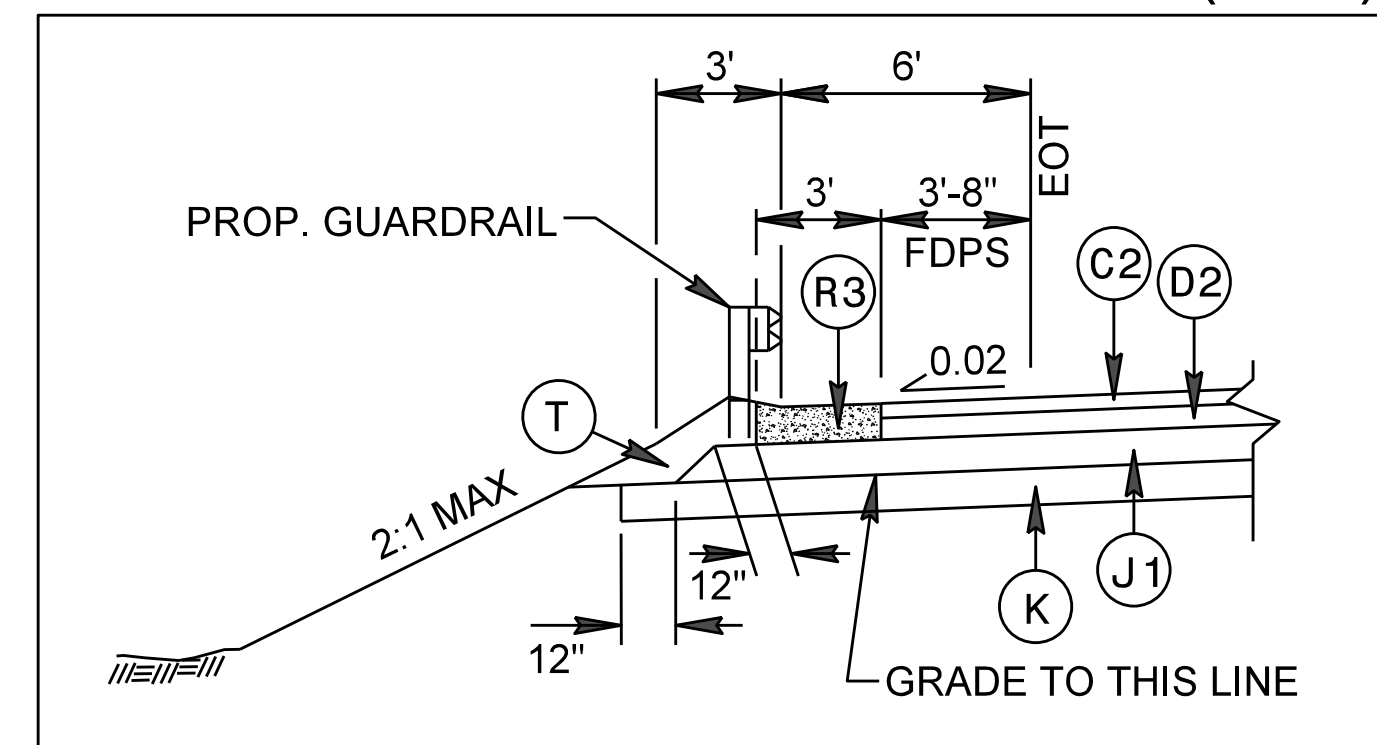

USE INSET "A" IN CONJUNCTION WITH TYPICAL SECTION NOS. 2 & 3

- L- STA. 16+10.00 TO 20+00.00 LT
- L- STA. 17+50.00 TO 18+47.36 RT
- L- STA. 19+70.41 TO 24+75.00 RT
- L- STA. 60+25.00 TO 67+29.50 LT
- L- STA. 68+40.00 TO 69+58.92 LT (BEGIN APPROACH SLAB)
- L- STA. 69+34.00 TO 69+58.92 RT (BEGIN APPROACH SLAB)
- L- STA. 72+32.01 (END APPROACH SLAB) TO 72+80.54 LT
- L- STA. 72+32.01 (END APPROACH SLAB) TO 72+50.00 RT

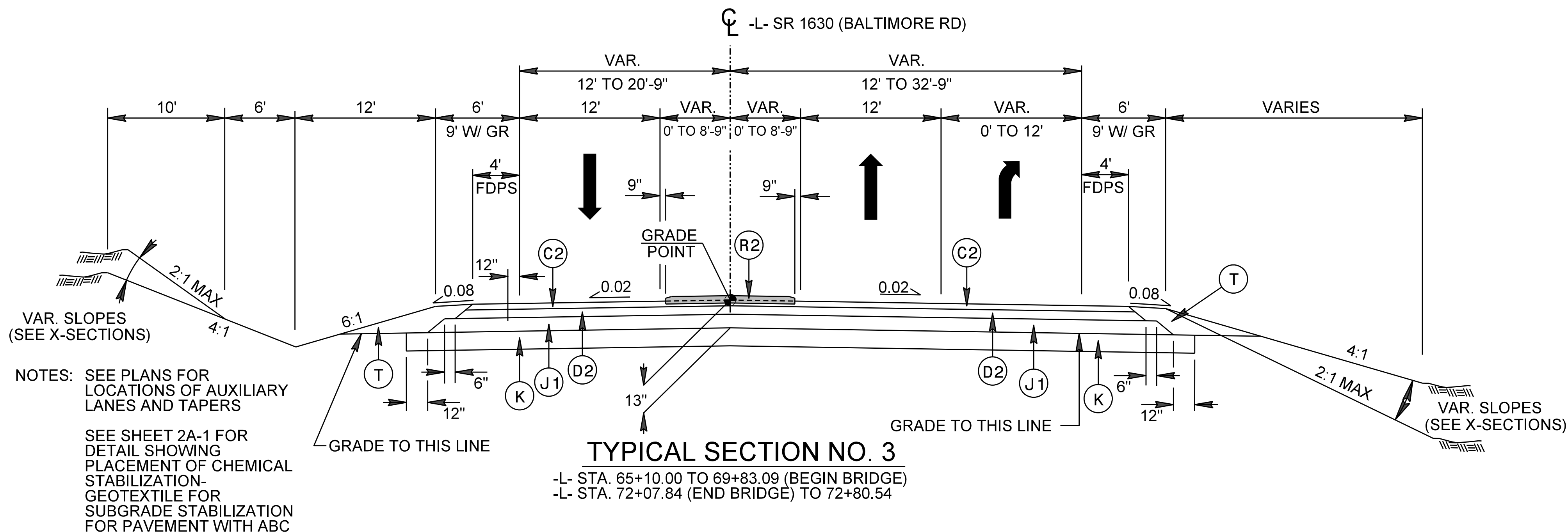

NOTES: SEE PLANS FOR LOCATIONS OF AUXILIARY LANES AND TAPERS
SEE SHEET 2A-1 FOR DETAIL SHOWING PLACEMENT OF CHEMICAL STABILIZATION-GEOTEXTILE FOR SUBGRADE STABILIZATION FOR PAVEMENT WITH ABC

