

### 18 CHANNEL CONFLICT MONITOR PROGRAMMING DETAIL

(remove jumpers and set switches as shown)

REMOVE DIODE JUMPERS 1-5, 1-6, 1-9, 1-11, 2-5, 2-6, 2-9, 2-11, 2-13, 3-8, 3-10, 3-12, 4-8, 4-10, 4-12, 5-9, 5-11, 5-13, 6-9, 6-11, 6-13, 8-10, 8-12, 9-11, 9-13, 10-12, AND 11-13.

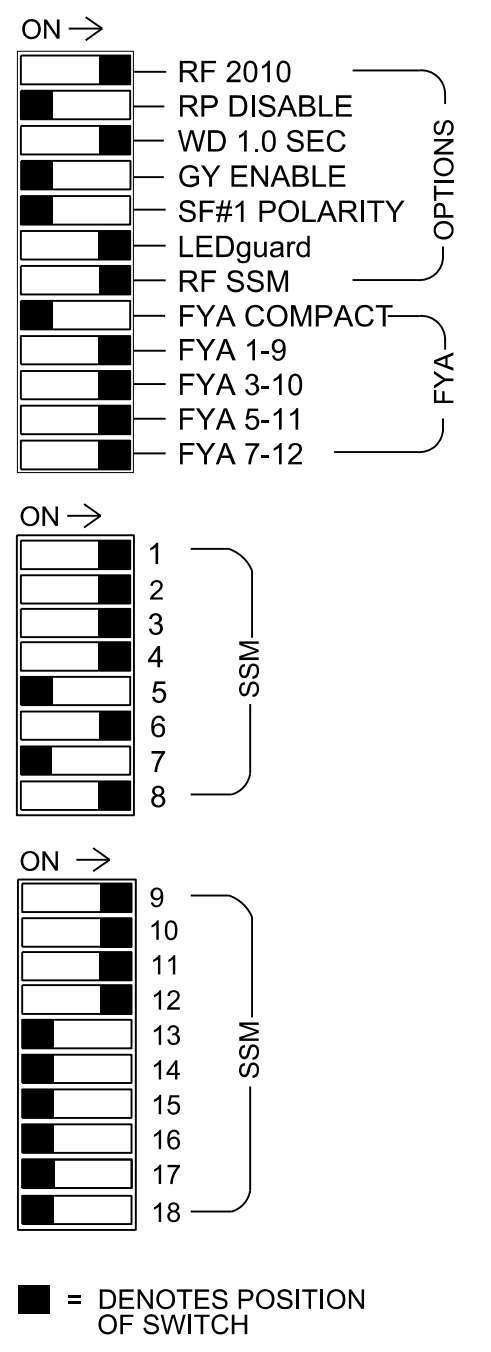
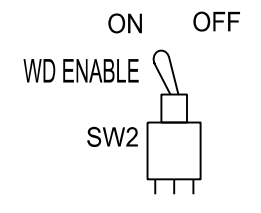
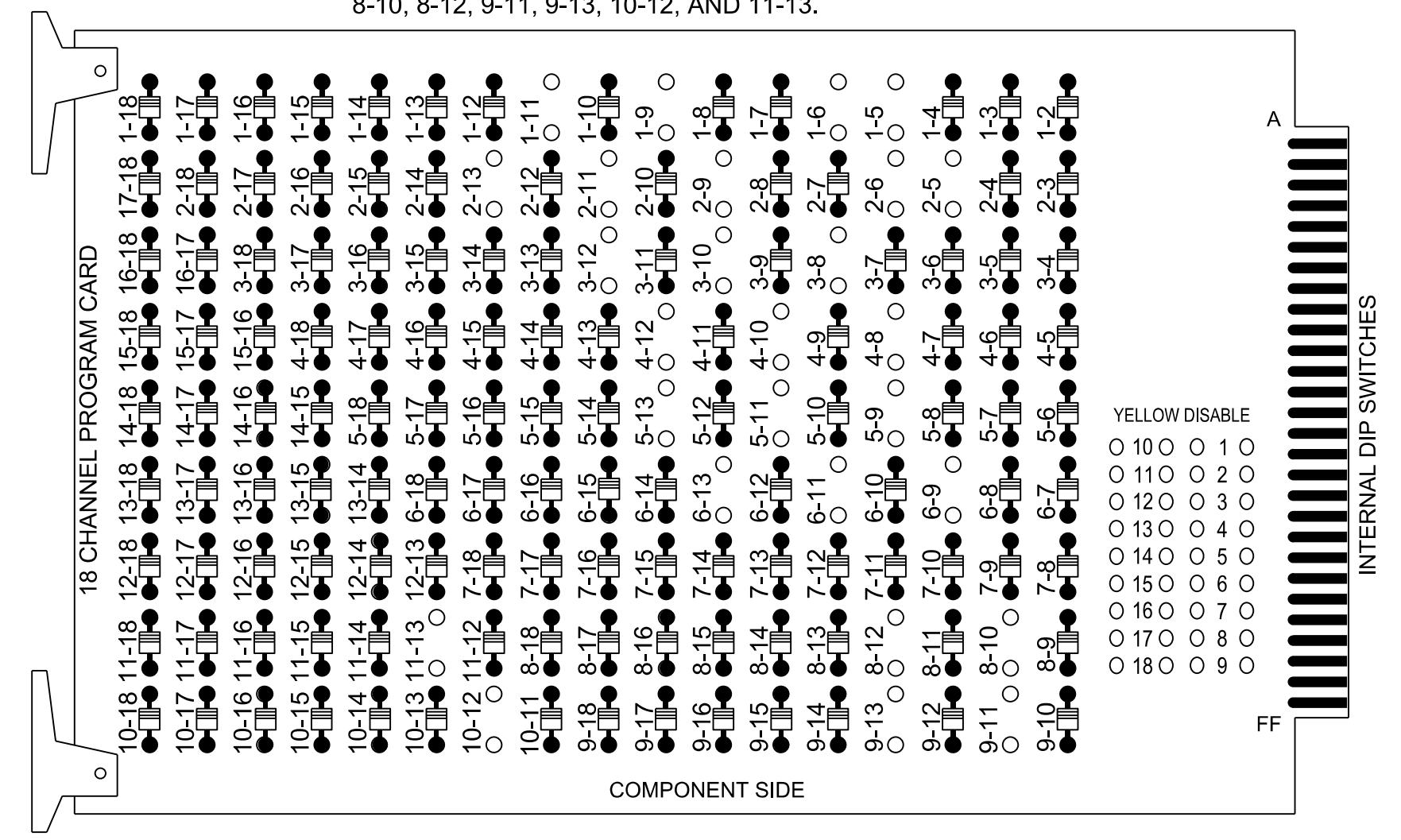

- NOTES:
- Card is provided with all diode jumpers in place. Removal of any jumper allows its channels to run concurrently.
  - Ensure jumpers SEL2-SEL5 and SEL9 are present on the monitor board.
  - Ensure that the Red Enable is active at all times during normal operation.
  - Connect serial cable from conflict monitor to comm. port 1 of 2070 controller. Ensure conflict monitor communicates with 2070.

### NOTES

- To prevent "flash-conflict" problems, insert red flash program blocks for all unused vehicle load switches in the output file. The installer shall verify that signal heads flash in accordance with the signal plan.
- Program phases 4 and 8 for Dual Entry.
- Program controller to start up in phase 2 Green No Walk and 6 Green No Walk.
- If this signal will be managed by an ATMS software, enable controller and detector logging for all detectors used at this location.
- The cabinet and controller are part of the NC 8 (Winston Road) Closed Loop System (Signal System D09-19 Lexington).

### EQUIPMENT INFORMATION

Controller.....2070LX  
 Cabinet.....332 w/ Aux  
 Software.....Q-Free MAXTIME  
 Cabinet Mount.....Base  
 Output File Positions.....18 With Aux. Output File  
 Load Switches Used.....S1, S2, S3, S4, S5, S7, S8, S11, AUX S1, AUX S2, AUX S4, AUX S5  
 Phases Used.....1, 2, 2 PED, 3, 4, 5, 6, 8  
 Overlap "1".....\*  
 Overlap "2".....\*  
 Overlap "3".....\*  
 Overlap "4".....\*  
 \*See overlap programming detail on sheet 2

### SIGNAL HEAD HOOK-UP CHART

LOAD SWITCH NO.	S1	S2	S3	S4	S5	S6	S7	S8	S9	S10	S11	S12	AUX S1	AUX S2	AUX S3	AUX S4	AUX S5	AUX S6		
CMU CHANNEL NO.	1	2	13	3	4	14	5	6	15	7	8	16	9	10	17	11	12	18		
PHASE	1	2	2 PED	3	4	4 PED	5	6	6 PED	7	8	8 PED	OL1	OL2	SPARE	OL3	OL4	SPARE		
SIGNAL HEAD NO.	82	11*	21,22	P21, P22	22	31*	42,43	NU	51*	61,62	NU	NU	81,82	NU	11*	31*	NU	51*	41*	NU
RED		*	128		*	101			134		107									
YELLOW			129			102		*	135		108									
GREEN			130			103			136		109									
RED ARROW																A121	A124		A114	A101
YELLOW ARROW	126					117										A122	A125		A115	A102
FLASHING YELLOW ARROW																A123	A126		A116	A103
GREEN ARROW	127	127		118	118				133											
Hand icon																				
Person icon																				

NU = Not Used  
 \* Denotes install load resistor. See load resistor installation detail this sheet.  
 \*See pictorial of head wiring in detail this sheet.

### INPUT FILE POSITION LAYOUT (front view)

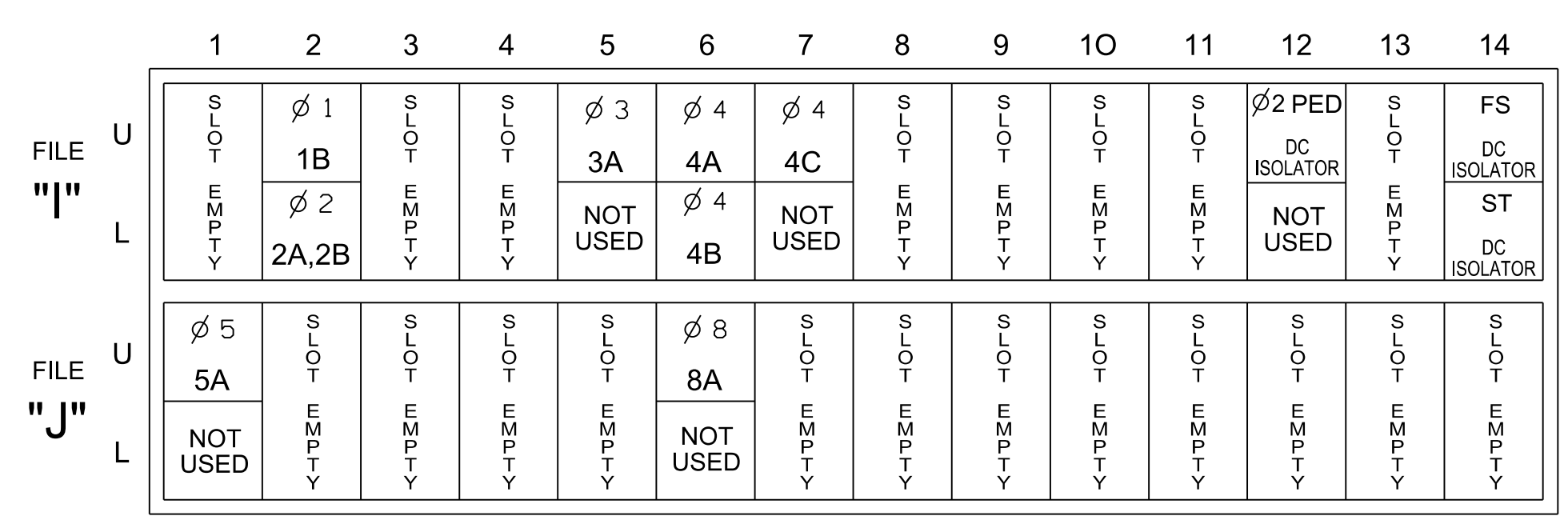

EX. : 1A, 2A, ETC. = LOOP NO.'S  
 FS = FLASH SENSE  
 ST = STOP TIME

### INPUT FILE CONNECTION & PROGRAMMING CHART

LOOP NO.	LOOP TERMINAL	INPUT FILE POS.	PIN NO.	INPUT POINT	DETECTOR NO.	CALL PHASE	DELAY TIME	EXTEND TIME	EXTEND	ADDED INITIAL	CALL	DELAY DURING GREEN
1B	TB2-5,6	I2U	39	1	2	1	15.0	...	X	-	X	-
2A,2B	TB2-7,8	I2L	43	5	3	2	...	...	X	-	X	-
3A	TB4-5,6	I5U	58	20	7	3	15.0	...	X	-	X	-
				-	30	8	...	...	X	-	X	-
4A	TB4-9,10	I6U	41	3	8	4	3.0	...	X	-	X	-
4B	TB4-11,12	I6L	45	7	9	4	10.0	...	X	-	X	-
4C	TB6-1,2	I7U	65	31	10	4	15.0	...	X	-	X	-
5A	TB3-1,2	J1U	55	17	15	5	15.0	...	X	-	X	-
				-	31	2	...	...	X	-	X	-
8A	TB5-9,10	J6U	42	4	22	8	...	...	X	-	X	-
PED PUSH BUTTONS												
P21,P22	TB8-4,6	I12U	67	33	2	PED 2	...	...	X	-	X	-

NOTE: INSTALL DC ISOLATORS IN INPUT FILE SLOT I12.

\* For the detectors to work as shown on the signal design plan, see the Vehicle Detector Programming Detail for Alternate Phasing Loops 1A & 5A on sheet 2.

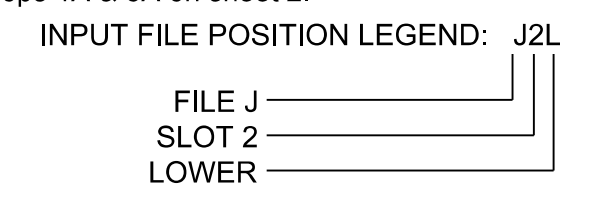

### FYA SIGNAL WIRING DETAIL (wire signal heads as shown)

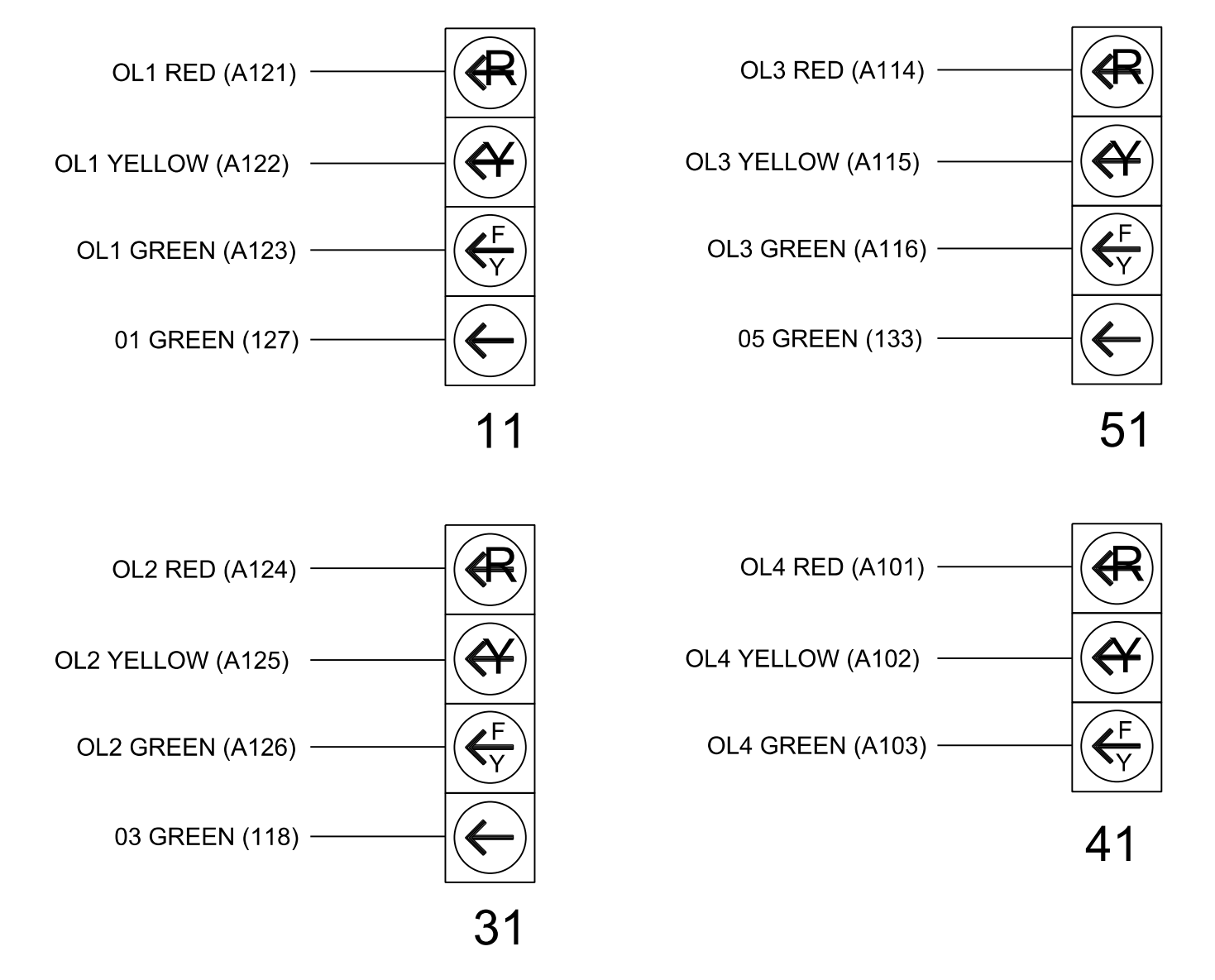

### LOAD RESISTOR INSTALLATION DETAIL (install resistors as shown)

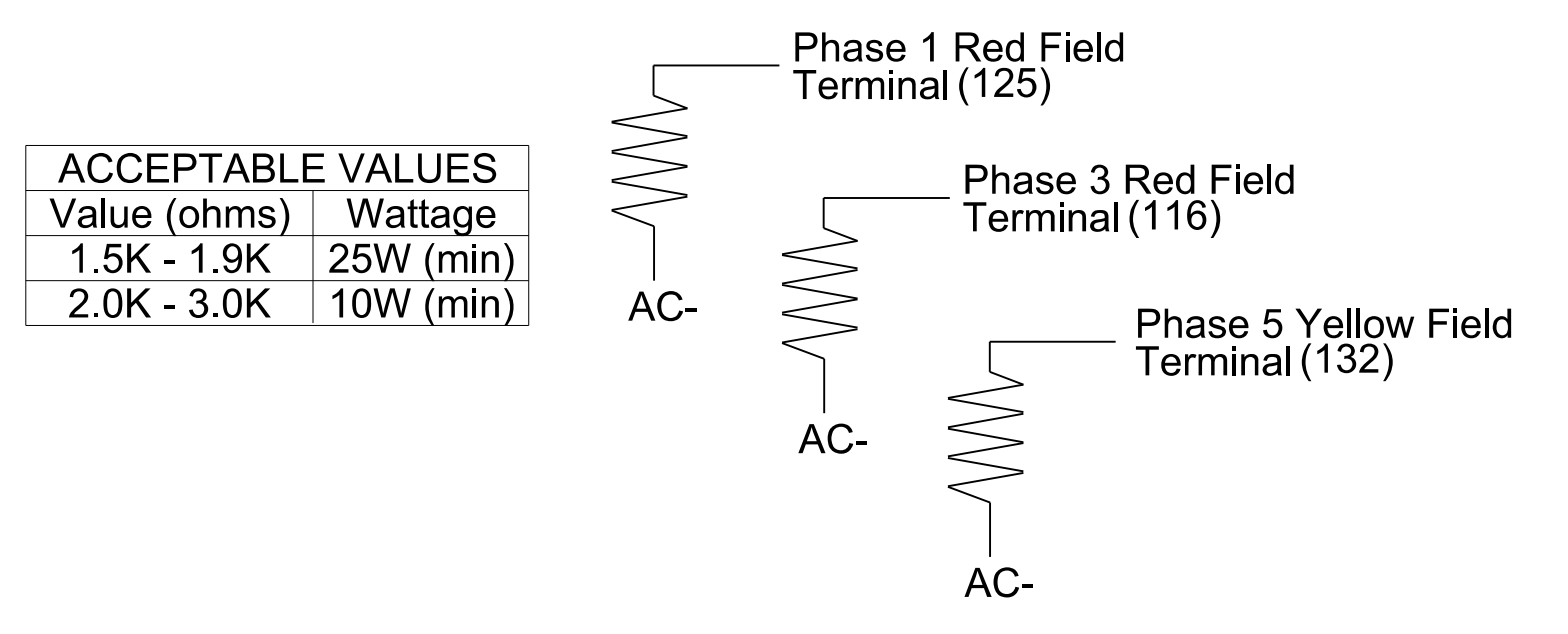

### SPECIAL DETECTOR NOTE

Install a video detection system for vehicle detection in zones 1A, 6A, and 6B. Perform installation according to manufacturer's directions and NCDOT engineer approved mounting locations to accomplish the detection schemes shown on the Signal Design Plans.

For zone 1A, inputs associated with the typical NCDOT installation slots are compatible with time of day instructions located on sheet 2.

### COUNTDOWN PEDESTRIAN SIGNAL OPERATION

Countdown Ped Signals are required to display timing only during Ped Clearance Interval. Consult Ped Signal Module user's manual for instructions on selecting this feature.

THIS ELECTRICAL DETAIL IS FOR THE SIGNAL DESIGN: 09-0735T2  
 DESIGNED: May 2024  
 SEALED: 09-10-2024  
 REVISED: N/A

Electrical Detail - Sheet 1 of 2

Prepared for the Offices of: **TRANSYSTEMS**

1 Glenwood Avenue  
 Raleigh, NC 27603  
 Tel: 919.789.9977  
 Fax: 919.789.9591  
 License: F-0453

NC 8 (Winston Road) at US 29 SB / US 64-70 WB Ramp

Division 9 Davidson County Lexington

PLAN DATE: May 2024 REVIEWED BY: J.T. Rowe, Jr.  
 PREPARED BY: J.T. Rowe REVIEWED BY: G.G. Murr, Jr.

REVISIONS: INIT. DATE

Signed by: **John T. Rowe, Jr.** 09/10/2024  
 SEAL NORTH CAROLINA PROFESSIONAL ENGINEER JOHN T. ROWE, JR. SEAL 008453  
 DOCUMENT NOT CONSIDERED FINAL UNLESS ALL SIGNATURES COMPLETED  
 SIG. INVENTORY NO. 09-0735T2