

NOTE:  
 SEE TMP-1A FOR TEMPORARY PAVEMENT MARKING SCHEDULE.  
 SEE ROADWAY PLANS FOR DETAILED DRAINAGE LAYOUT.  
 USE ADA COMPLIANT PEDESTRIAN BARRICADE TO KEEP PROPOSED SIDEWALK CLOSED UNTIL CONNECTIVITY IS ACHIEVED.

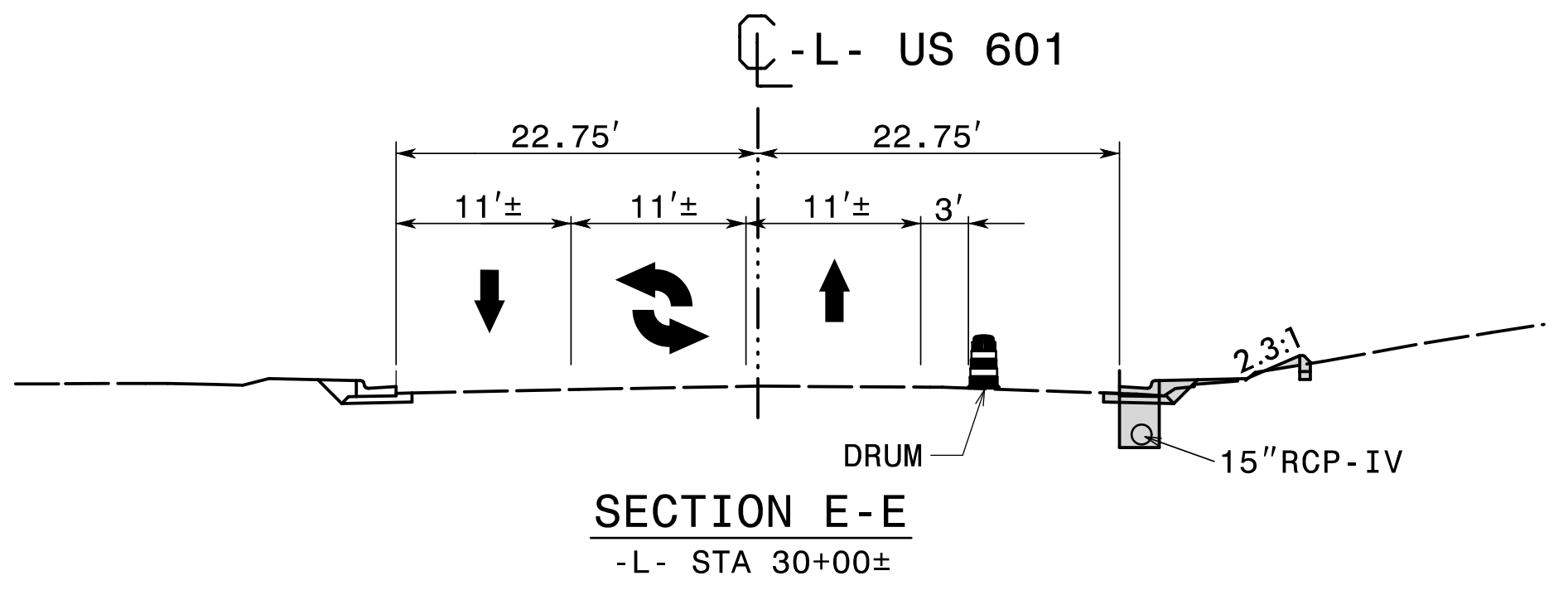

NOTE: PAVE AND WEDGE AS DIRECTED BY THE ENGINEER TO MAINTAIN DRAINAGE AND MITIGATE PAVING EDGE DROP-OFFS.

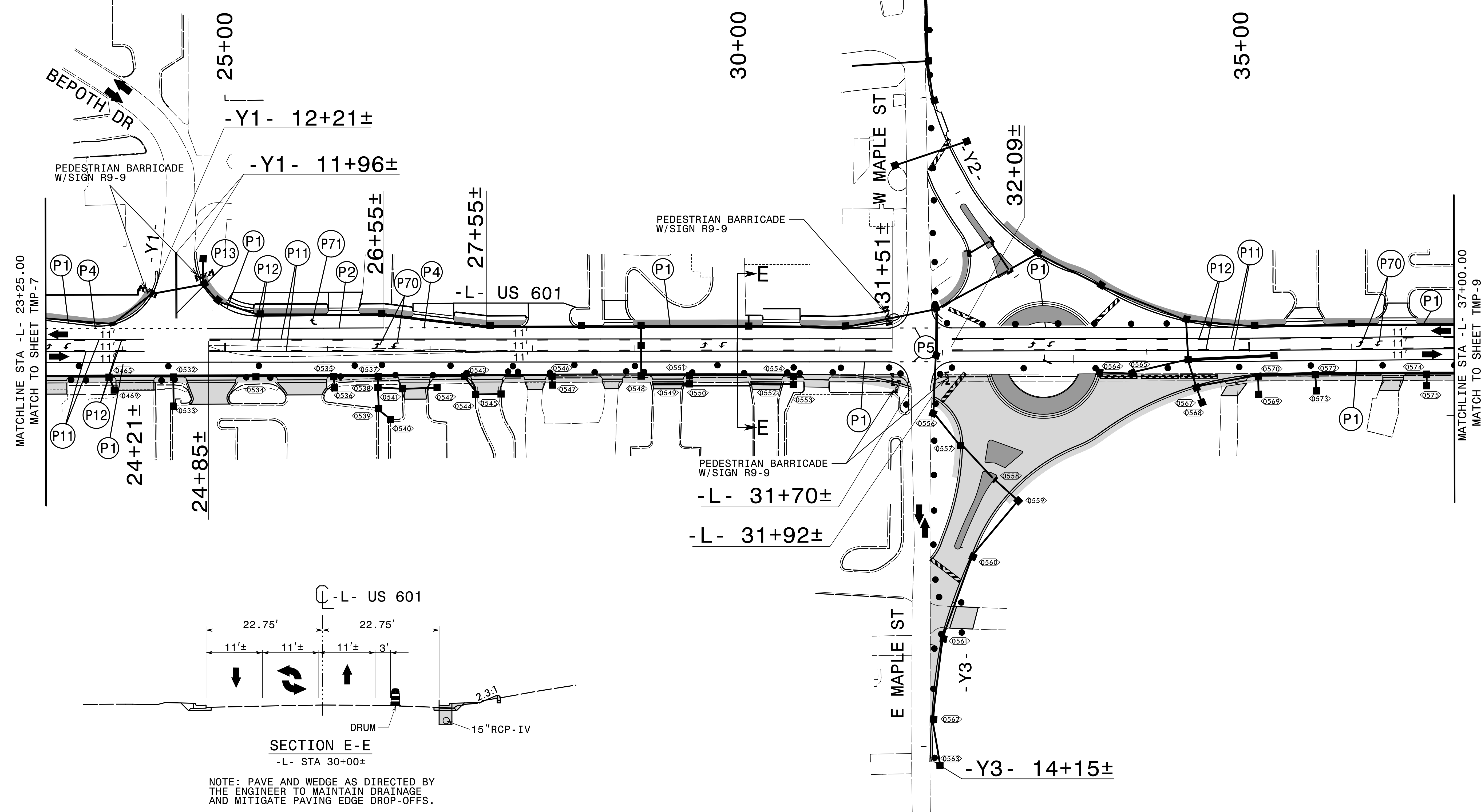
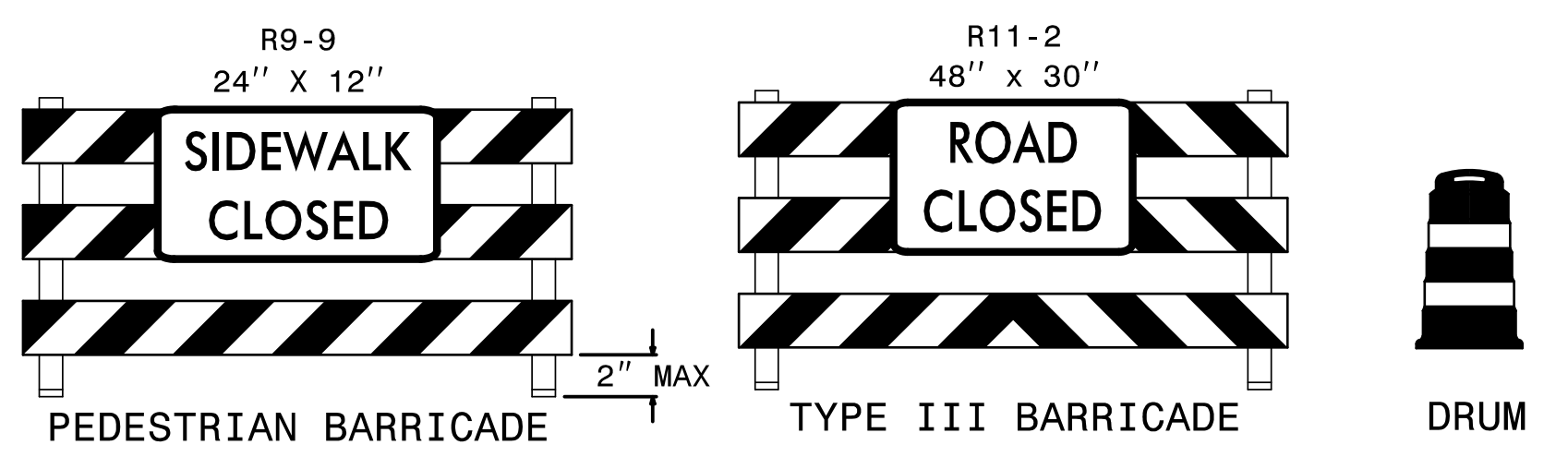

APPROVED: *Don A. Parker*  
75089690ADEF440

DATE: 3/27/2024

SEAL

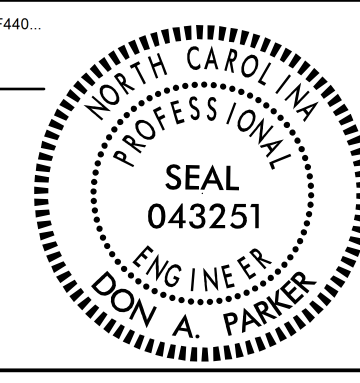

DOCUMENT NOT CONSIDERED FINAL  
 UNLESS ALL SIGNATURES COMPLETED



TEMPORARY TRAFFIC CONTROL PHASE II

3/26/2024  
 U:\Projects\U-5809\Traffic\TrafficControl\TCP\U-5809\_TC\_TMP\_08.dgn  
 User: jsmelvin