

For Slopes Excavated Greater Than 10 feet
 Install Matting for Erosion Control on
 Entire Slope as Work Allows.

Note: Reforestation provided for revegetation of areas
 after basin removal as needed and as directed by the engineer.

21 x 10 x 3
 1.5 inch Skimmer
 with 0.25 inch
 Orifice Diameter
 4 ft. weir
 ID 4.3

34 x 33 x 3
 1.5 inch Skimmer
 with 0.875 inch
 Orifice Diameter
 4 ft. weir
 ID 4.1

39 x 14 x 3
 1.5 inch Skimmer
 with 0.5 inch
 Orifice Diameter
 4 ft. weir
 ID 4.2

Temporary Rock
 Sediment
 Dam Type A
 2.5 ft. weir height

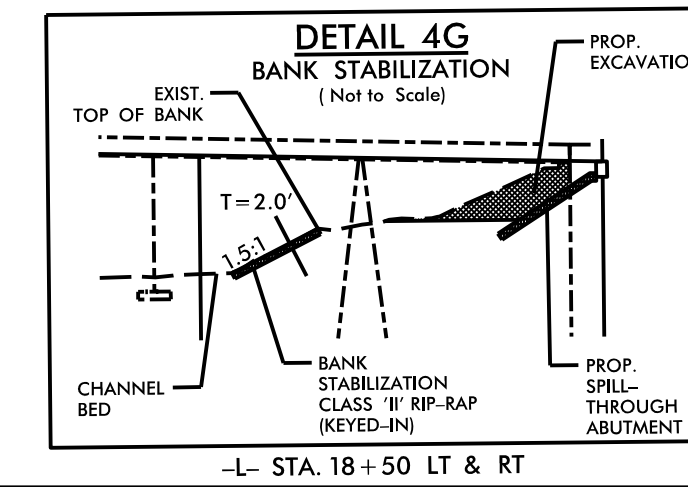
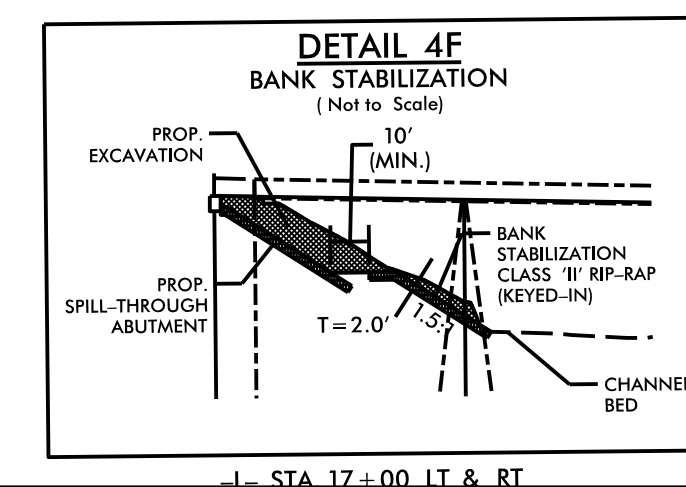
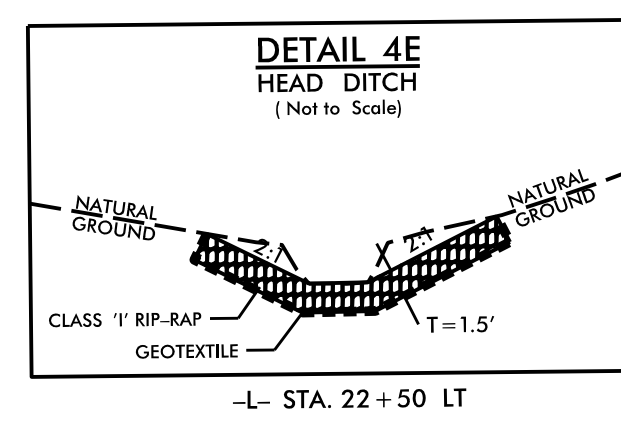
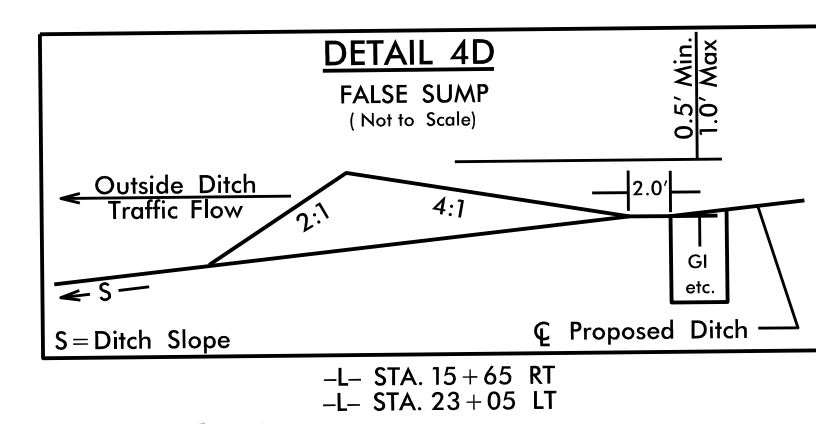
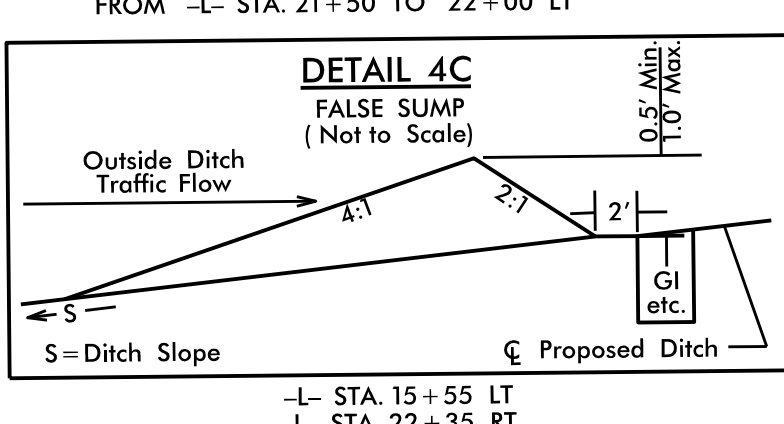
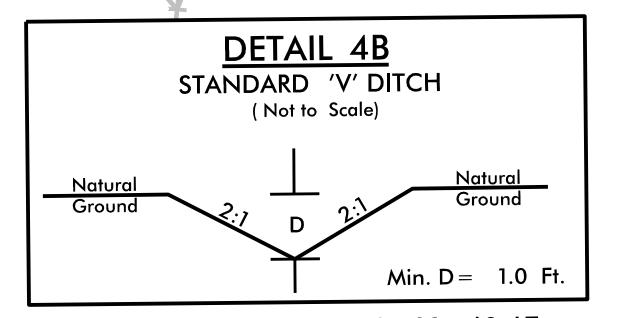
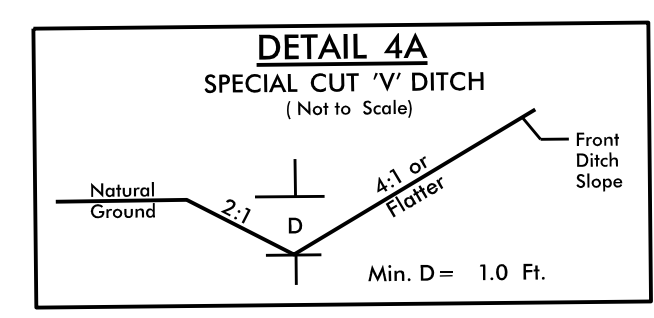
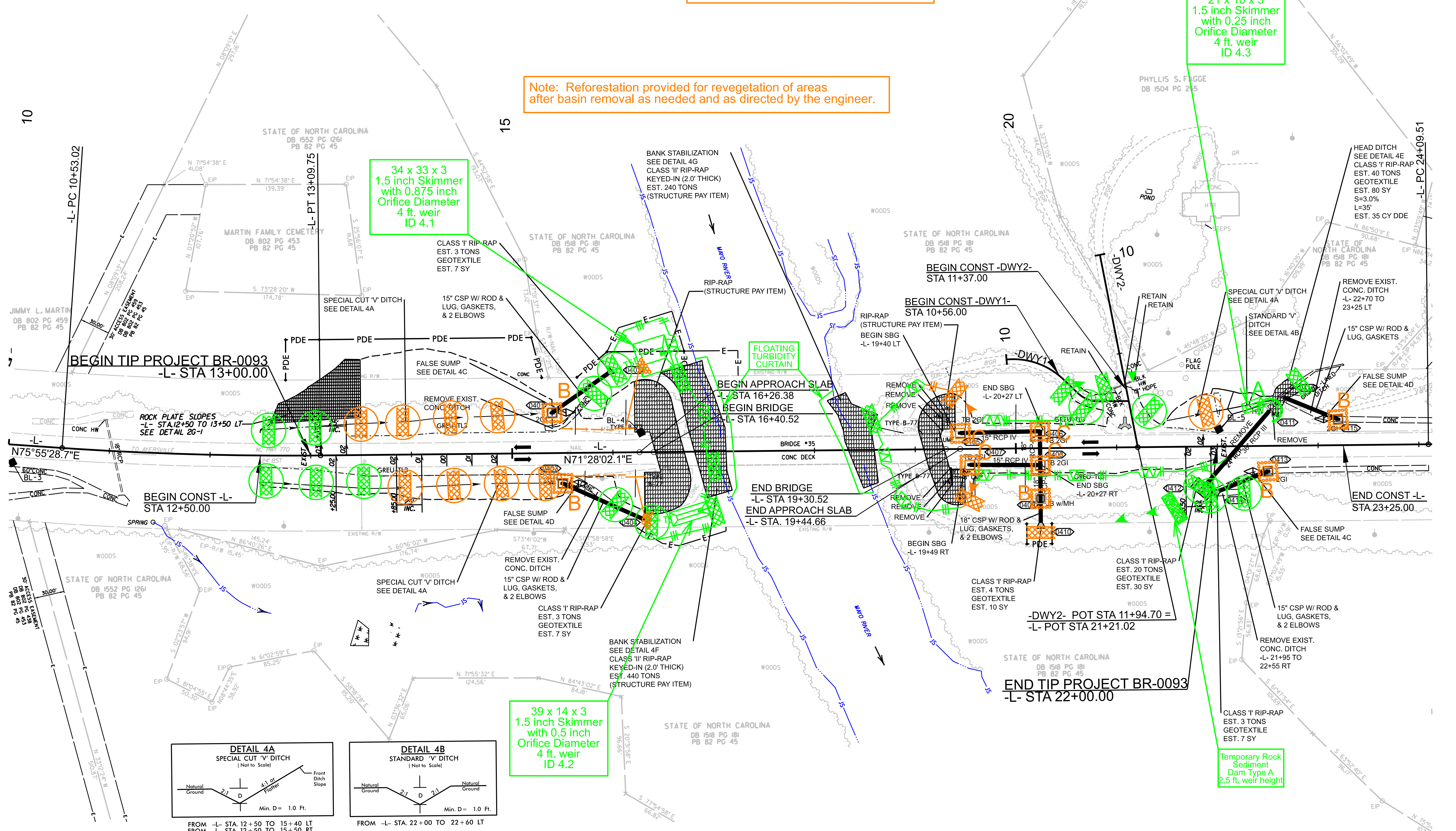

NOTE:
 UTILIZE TEMPORARY SEDIMENT BASIN OR SPECIAL STILLING
 BASIN(S) AS STILLING BASIN WHERE APPLICABLE.

REVISIONS