

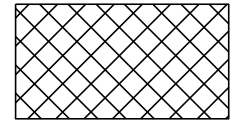
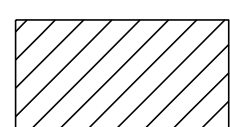

COLUMN 1                      COLUMN 2

ELEVATION @ BENT 7 (SPAN G)

AS-BUILT REPAIR QUANTITY TABLE				
REPAIRS BENT 7	QUANTITIES			
	ESTIMATE		ACTUAL	
SHOTCRETE REPAIRS	AREA SF	VOLUME CF	AREA SF	VOLUME CF
CAP	20.1	10.1		
COLUMN	136.0	68.0		
CONCRETE REPAIRS	AREA SF	VOLUME CF	AREA SF	VOLUME CF
CAP	0.0	0.0		
COLUMN	0.0	0.0		
EPOXY RESIN INJECTION		LN. FT.		LN. FT.
CAP		14.0		
COLUMN		42.5		
EPOXY COATING		SQ. FT.		SQ. FT.
TOP OF BENT CAP		70.0		

VALUES IN CHART REPRESENT ESTIMATED REPAIR TOTALS AFTER REMOVAL OF UNSOUND CONCRETE, MIN. OF 1" BEHIND REBAR AND 2" MIN. CLEAR TO SAWCUT.

 SHOTCRETE REPAIR  
 CONCRETE REPAIR  
 EPOXY RESIN INJECTION (ERI)

PROJECT NO. 15BPR.130  
MOORE COUNTY  
 BRIDGE NO. 620072

SHEET 1 OF 2

STATE OF NORTH CAROLINA  
 DEPARTMENT OF TRANSPORTATION  
 RALEIGH

**BENT 7**

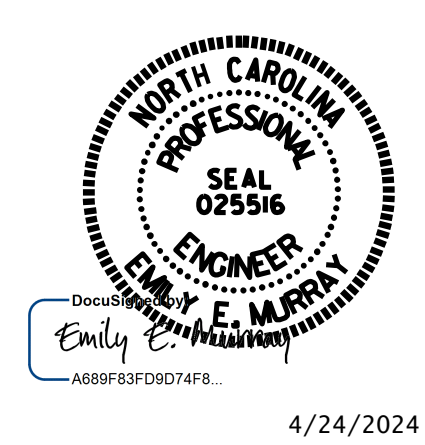

**VOLKERT**  
 5540 Centerview Drive, Suite 305  
 Raleigh, NC 27606  
 Tel. 919-854-0344 Fax. 919-854-0355  
 NC License No. F-0765

DOCUMENT NOT CONSIDERED FINAL UNLESS ALL SIGNATURES COMPLETED

REVISIONS						SHEET NO.
NO.	BY:	DATE:	NO.	BY:	DATE:	
1			3			S-146
2			4			TOTAL SHEETS: 156

DRAWN BY : C.NICHOLS DATE : 01/24  
 CHECKED BY : P.N.HOLDER DATE : 03/24