

AS-BUILT REPAIR QUANTITY TABLE

TOP OF DECK REPAIRS





SPAN B

	ESTIMATE	ACTUAL
SCARIFYING BRIDGE DECK	205.3 SY	
HYDRO-DEMOLITION OF BRIDGE DECK	205.3 SY	
CLASS II SURFACE PREPARATION	2.3 SY	
CLASS III SURFACE PREPARATION	0.0 SY	
LMC OVERLAY-VES	8.6 CY	
PLACING AND FINISHING LMC OVERLAY-VES	205.3 SY	
GROOVING BRIDGE FLOORS	1641.7 SF	
BRIDGE JOINT DEMOLITION	21.7 SF	

UNDERSIDE OF DECK REPAIRS

SHOTCRETE REPAIRS	ESTIMATE		ACTUAL
	AREA SF	VOLUME CF	AREA SF
UNDERSIDE OF DECK	0.0	0.0	
OVERHANG DIAPHRAGMS	0.0	0.0	
UNDERSIDE OF OVERHANG	16.0	3.4	
INTERIOR DIAPHRAGMS	10.3	3.7	
	ESTIMATE	ACTUAL	
UNDERSIDE EPOXY RESIN INJECTION	0.0 LF		

QUANTITIES IN TABLE REPRESENT ESTIMATED REPAIR TOTALS AFTER REMOVAL OF UNSOUND CONCRETE, MINIMUM OF 1" BEHIND REBAR, AND MINIMUM 2" CLEAR TO SAW CUT. SEE REPAIR DETAILS.

-  CLASS II SURFACE PREPARATION
-  BRIDGE JOINT DEMOLITION
-  UNDERSIDE REPAIR
-  TEST LOCATION

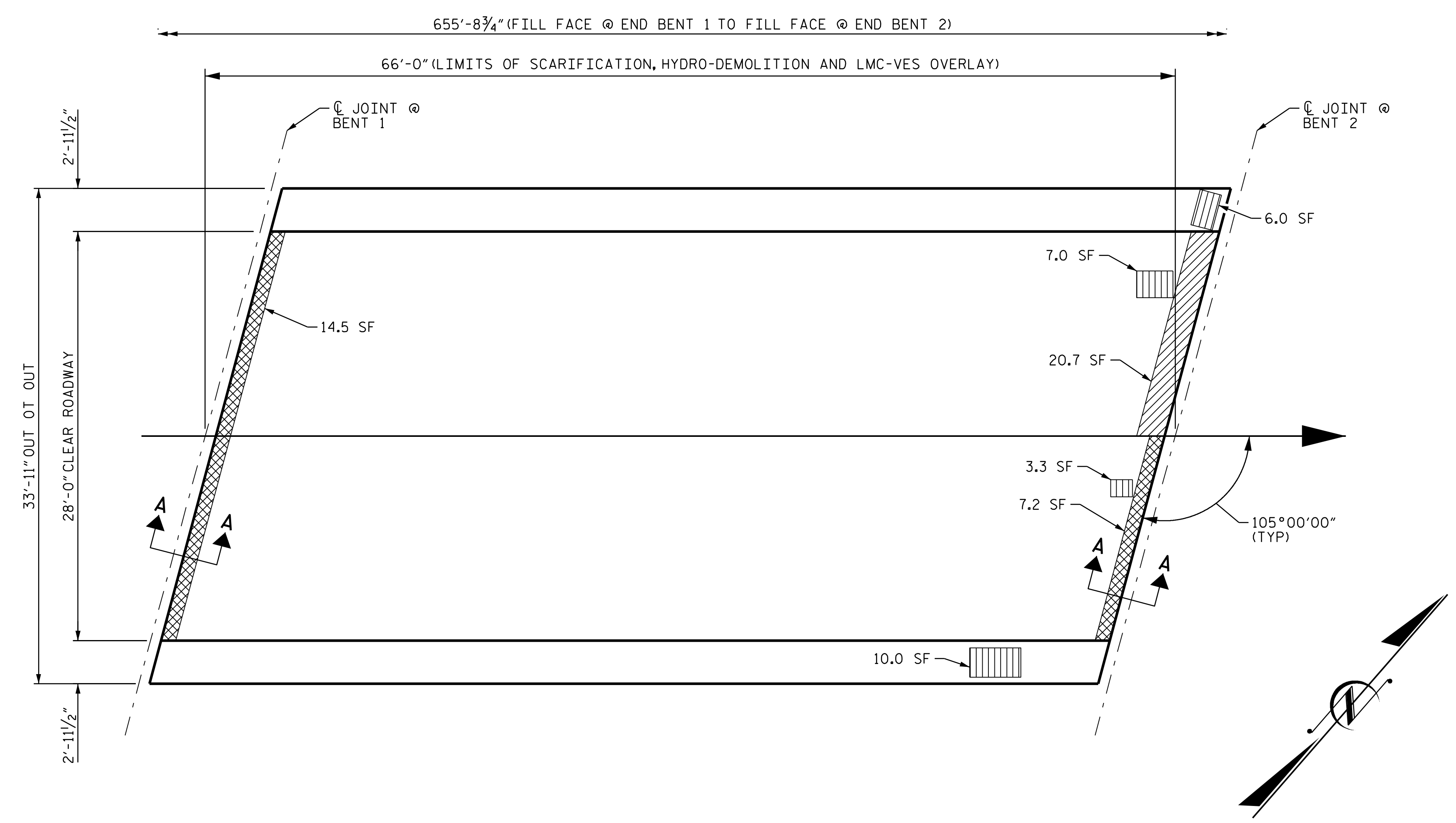

PLAN OF SPAN B

NOTES

REPAIR LOCATIONS AND ESTIMATE OF QUANTITIES ARE BASED ON THE BEST INFORMATION AVAILABLE. IF ADDITIONAL REPAIRS NOT SHOWN ON THE DRAWINGS ARE DEEMED NECESSARY BY THE ENGINEER, THE ENGINEER WILL NOTE ON THE DRAWINGS THE APPROXIMATE LOCATIONS AND DESCRIPTION OF THE REPAIRS AND ENTER THE ACTUAL QUANTITIES INTO THE AS-BUILT REPAIR QUANTITY TABLE.

FOR SHOTCRETE REPAIRS, SEE SPECIAL PROVISIONS.

FOR CONCRETE FOR DECK REPAIR, SEE SPECIAL PROVISIONS.

THE BOUNDARIES OF AREAS IDENTIFIED FOR CLASS II (PARTIAL DEPTH) SURFACE PREPARATION ARE APPROXIMATE AND MAY NOT REFLECT ACTUAL CONDITIONS THAT WILL BE ENCOUNTERED AT THE PROJECT SITE.

EXISTING JOINTS AND DECK DRAINS SHALL BE SEALED PRIOR TO BEGINNING SURFACE PREPARATION OF THE BRIDGE DECK.

FOR OVERLAY OF BRIDGE WITH LATEX MODIFIED CONCRETE- VERY EARLY STRENGTH, SEE SPECIAL PROVISIONS.

PREVIOUSLY PLACED LMC OVERLAY AT STAGED EDGES SHALL BE DEMOLISHED BACK A MINIMUM OF 4 INCHES AND RECAST WITH LMC.

FOR LMC OVERLAY - VES SURFACE PREPARATION, SEE SPECIAL PROVISIONS.

FINAL JOINT SEALS SHALL NOT BE INSTALLED UNTIL THE OVERLAY IS COMPLETE

FOR BRIDGE JOINT DEMOLITION, SEE SPECIAL PROVISIONS.

FOR SECTION A-A, SEE "JOINT REPAIR DETAILS" SHEET.

PROJECT NO. 15BPR.130
MOORE COUNTY
 STATION: 620072

SHEET 2 OF 10

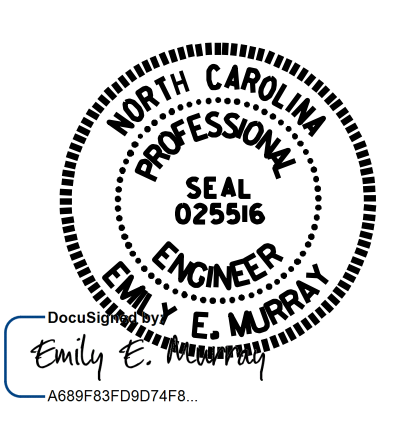

STATE OF NORTH CAROLINA
 DEPARTMENT OF TRANSPORTATION
 RALEIGH

PLAN OF SPAN B

DRAWN BY : B. H. BARNHILL DATE : 03/2024
 CHECKED BY : E. E. MURRAY DATE : 03/2024
 DESIGN ENGINEER OF RECORD: E. E. MURRAY DATE : 03/2024

DOCUMENT NOT CONSIDERED
 FINAL UNLESS ALL
 SIGNATURES COMPLETED

REVISIONS						SHEET NO.
NO.	BY:	DATE:	NO.	BY:	DATE:	S-122
1			3			TOTAL SHEETS
2			4			156