

SLOPE CASE

**SEE ROADWAY PLANS FOR CONCRETE DITCH AND FINISHED GRADE DETAILS.

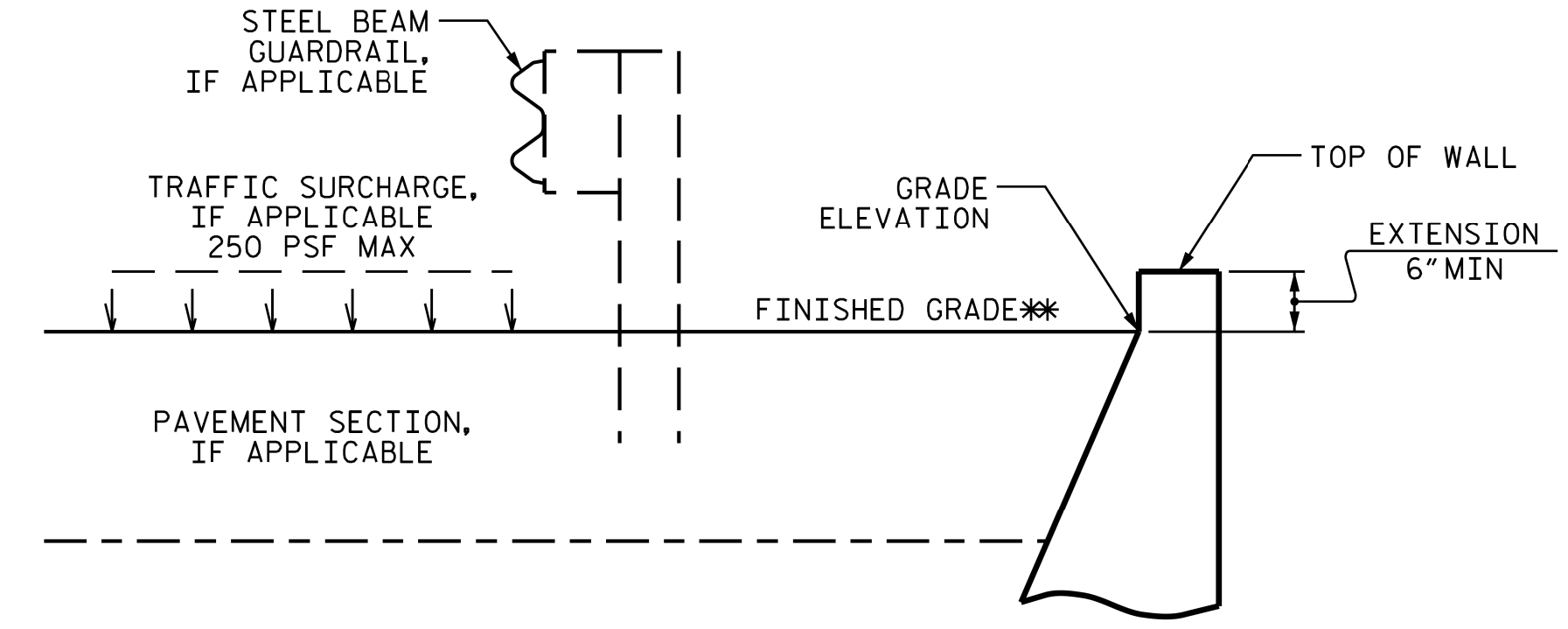

NO SLOPE CASE

**SEE ROADWAY PLANS FOR FINISHED GRADE DETAILS.

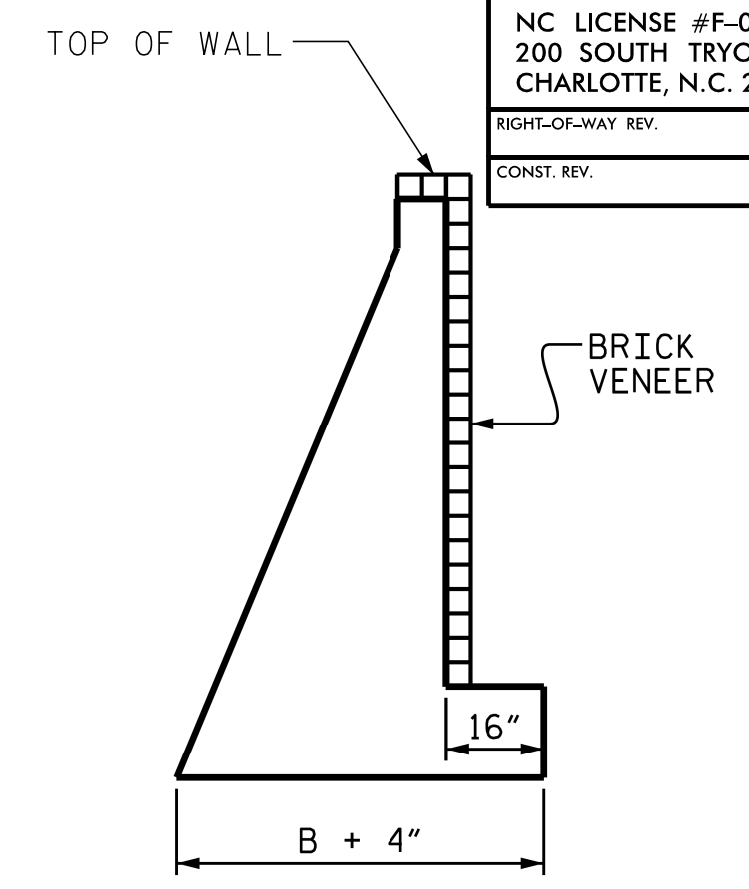

BRICK VENEER DETAIL

(WHEN APPLICABLE)

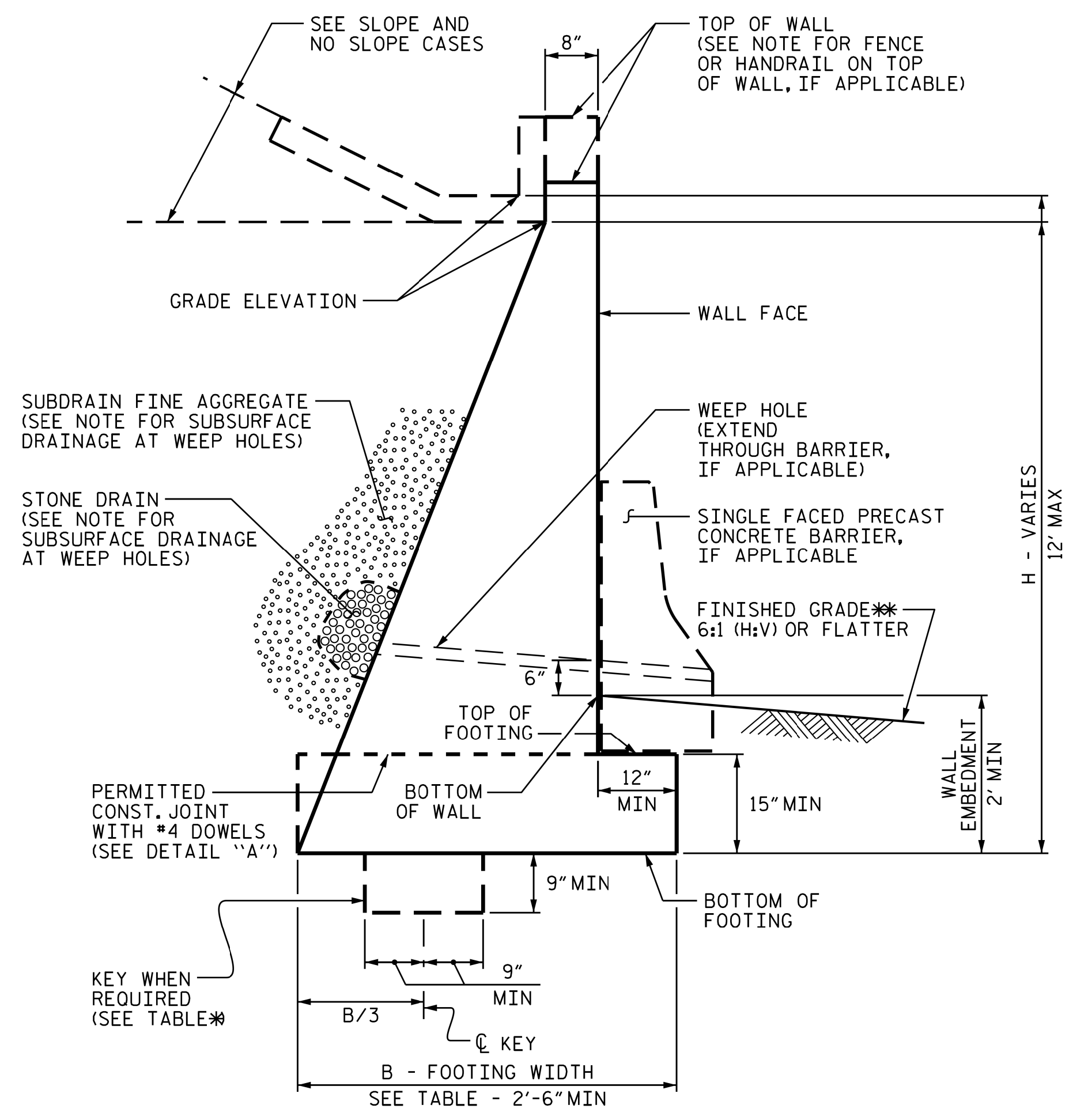

STANDARD CIP GRAVITY WALL

**SEE ROADWAY PLANS FOR FINISHED GRADE DETAILS.

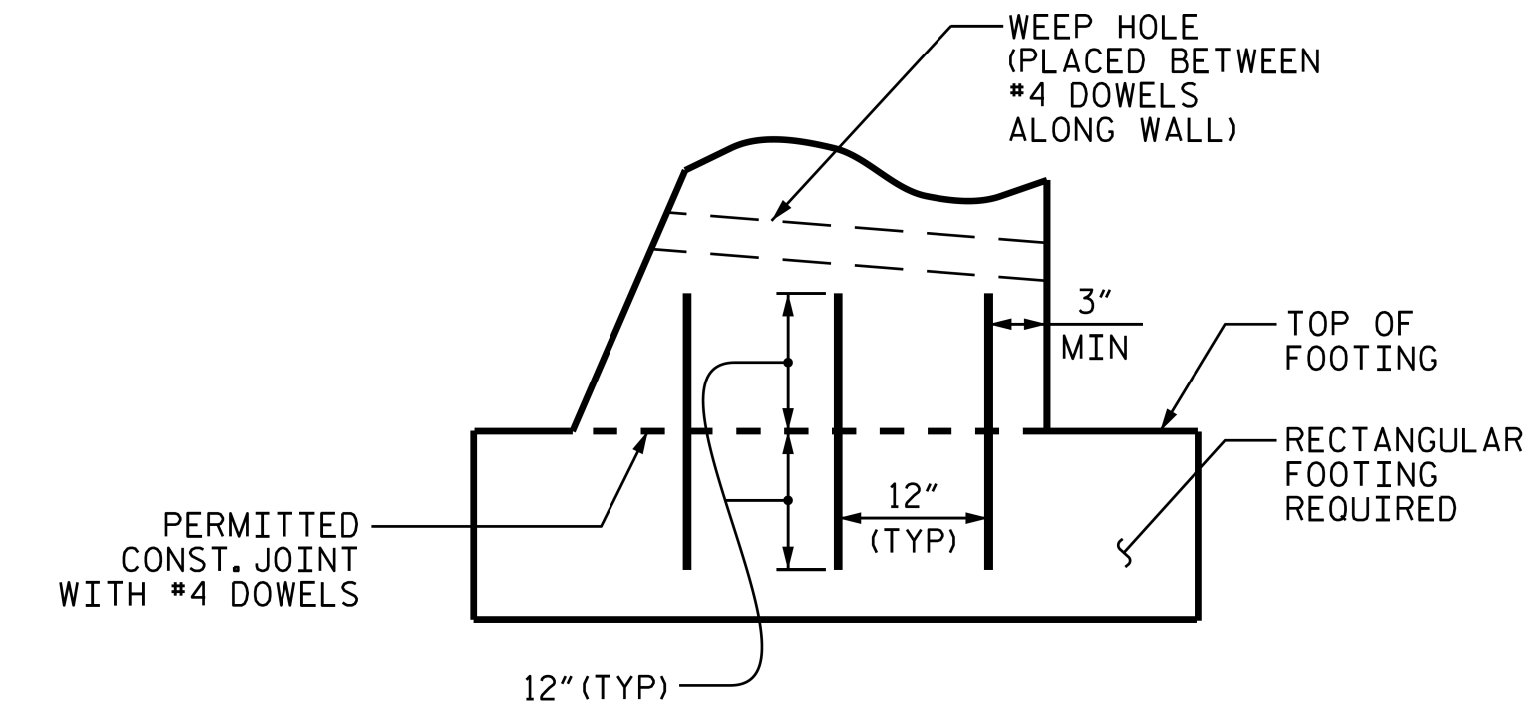

DETAIL "A"

H (FT)	3 - < 6	6 - 9	> 9 - 12
SLOPE CASE	.66	.70*	.75*
NO SLOPE CASE WITH TRAFFIC SURCHARGE	.80	.75*	.70*
NO SLOPE CASE WITHOUT TRAFFIC SURCHARGE	.60	.60	.60

B/H RATIO (B = 2'-6" MIN)

*KEY IS REQUIRED FOR "SLOPE CASE" OR "NO SLOPE CASE WITH TRAFFIC SURCHARGE" WHEN H IS 6' OR GREATER.

NOTES:

- FOR STANDARD CIP GRAVITY RETAINING WALLS, SEE SECTION 453 OF THE STANDARD SPECIFICATIONS.
- FOR STEEL BEAM GUARDRAIL, SEE ROADWAY PLANS AND SECTION 862 OF THE STANDARD SPECIFICATIONS.
- FOR SINGLE FACED PRECAST CONCRETE BARRIER, SEE ROADWAY PLANS AND SECTION 857 OF THE STANDARD SPECIFICATIONS.
- FOR FENCES OR HANDRAILS ON TOP OF WALLS, SEE ROADWAY PLANS FOR FENCE OR HANDRAIL ATTACHMENT DETAILS.
- FOR SUBSURFACE DRAINAGE AT WEEP HOLES, SEE ARTICLE 414-8 OF THE STANDARD SPECIFICATIONS.
- STANDARD CIP GRAVITY WALLS ARE BASED ON THE FOLLOWING IN-SITU ASSUMED SOIL PARAMETERS:
UNIT WEIGHT, $\gamma = 120$ PCF
FRICTION ANGLE, $\phi = 35$ DEGREES (GROUNDWATER WITHIN 7' OF BOTTOM OF FOOTING)
FRICTION ANGLE, $\phi = 30$ DEGREES (GROUNDWATER MORE THAN 7' BELOW BOTTOM OF FOOTING)
COHESION, $c = 0$ PSF
- DO NOT USE STANDARD CIP GRAVITY WALLS IF ASSUMED SOIL PARAMETERS ARE NOT APPLICABLE OR GROUNDWATER IS ABOVE BOTTOM OF FOOTING.
- DO NOT USE STANDARD CIP GRAVITY WALLS WHEN VERY LOOSE OR SOFT SOIL OR MUCK IS BELOW WALLS.
- BEFORE BEGINNING STANDARD CIP GRAVITY WALL CONSTRUCTION, SURVEY WALL LOCATIONS AND SUBMIT WALL PROFILE VIEWS (WALL ENVELOPES) FOR REVIEW. FOR WALL ENVELOPES, INCLUDE BOTTOM OF WALL, EXISTING GROUND AND GRADE ELEVATIONS AND OTHER ELEVATIONS AS NEEDED AT INTERVALS OF 25' OR LESS ALONG WALLS. DO NOT START WALL CONSTRUCTION UNTIL WALL ENVELOPES ARE ACCEPTED.
- FOR BRICK VENEERS, SUBMIT BRICK SAMPLES FOR APPROVAL BEFORE BEGINNING STANDARD CIP GRAVITY WALL CONSTRUCTION.
- DO NOT PLACE CONCRETE FOR FOOTINGS UNTIL EXCAVATION DIMENSIONS AND FOUNDATION MATERIAL ARE APPROVED.
- WHEN CONSTRUCTING STANDARD CIP GRAVITY WALLS WITH A CONSTRUCTION JOINT AS SHOWN IN DETAIL "A", PROVIDE A MINIMUM OF 3 EQUALLY SPACED #4 DOWELS AT INTERVALS OF 1'-6" ALONG WALLS.

K:\CHL_PRA\01036359 - U-5108 (Northcross)\DSM\Roadway\Proj\U-5108_rdy_psh_2E-1.dgn

4/9/2024

<p>NC LICENSE #F-0102 200 SOUTH TRYON, SUITE 200 CHARLOTTE, N.C. 28202</p>	<p>NORTH CAROLINA DEPARTMENT OF TRANSPORTATION DIVISION OF HIGHWAYS</p> <p>GEOTECHNICAL ENGINEERING UNIT</p>	<p>STANDARD DETAIL NO. 453.01</p>
		<p>STANDARD CIP GRAVITY RETAINING WALL</p>