

EXISTING JOINT

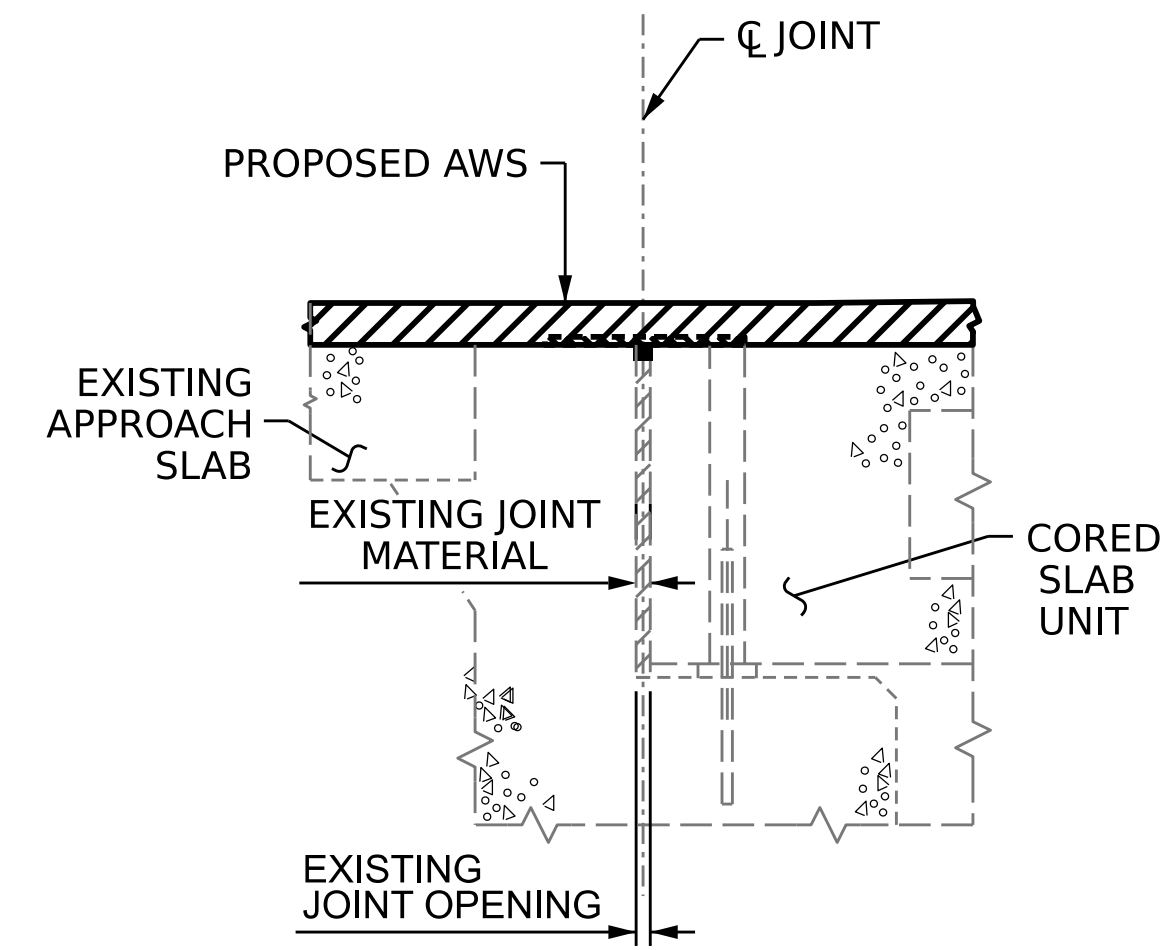

EXISTING JOINT  
(AFTER PROPOSED AWS IS PLACED)

**EXISTING JOINT DETAILS AT END BENTS**

SECTION A-A

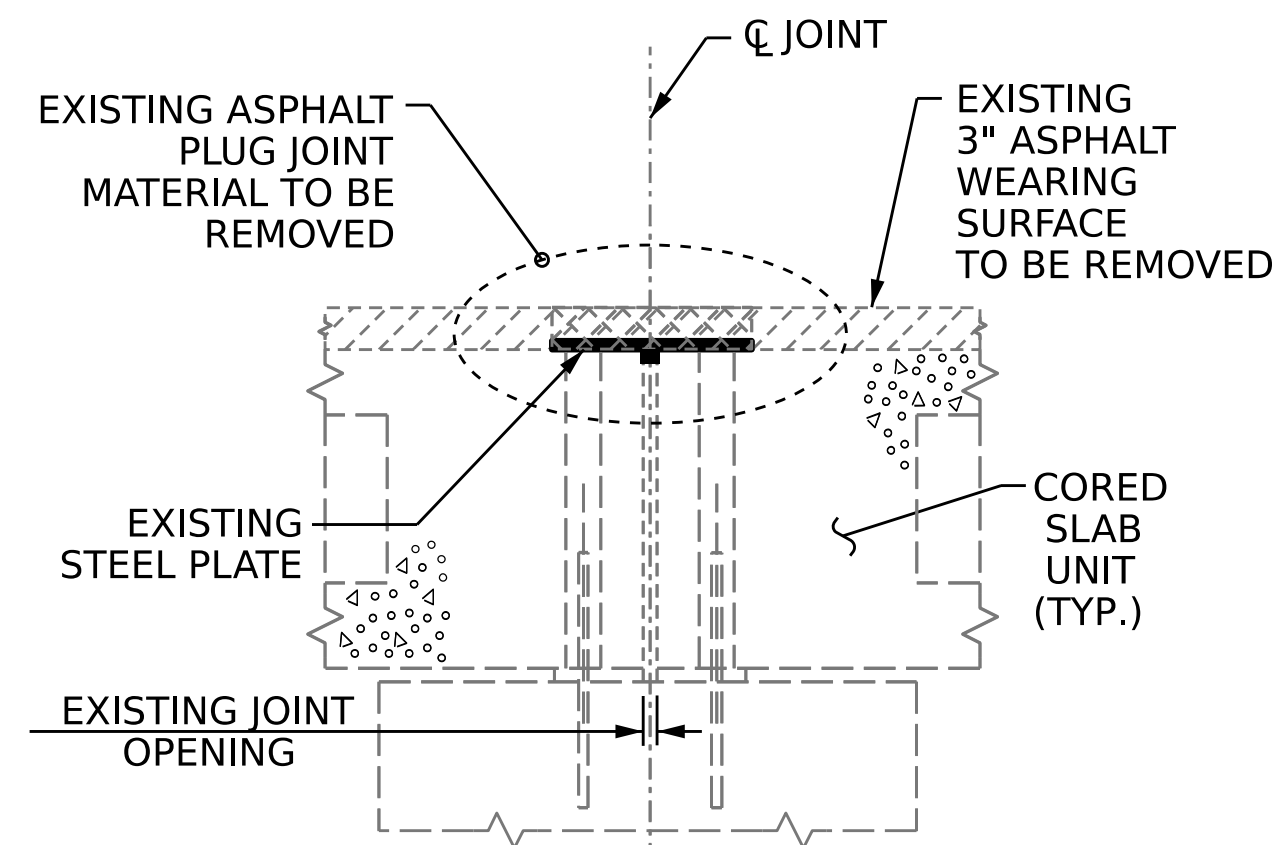

EXISTING JOINT

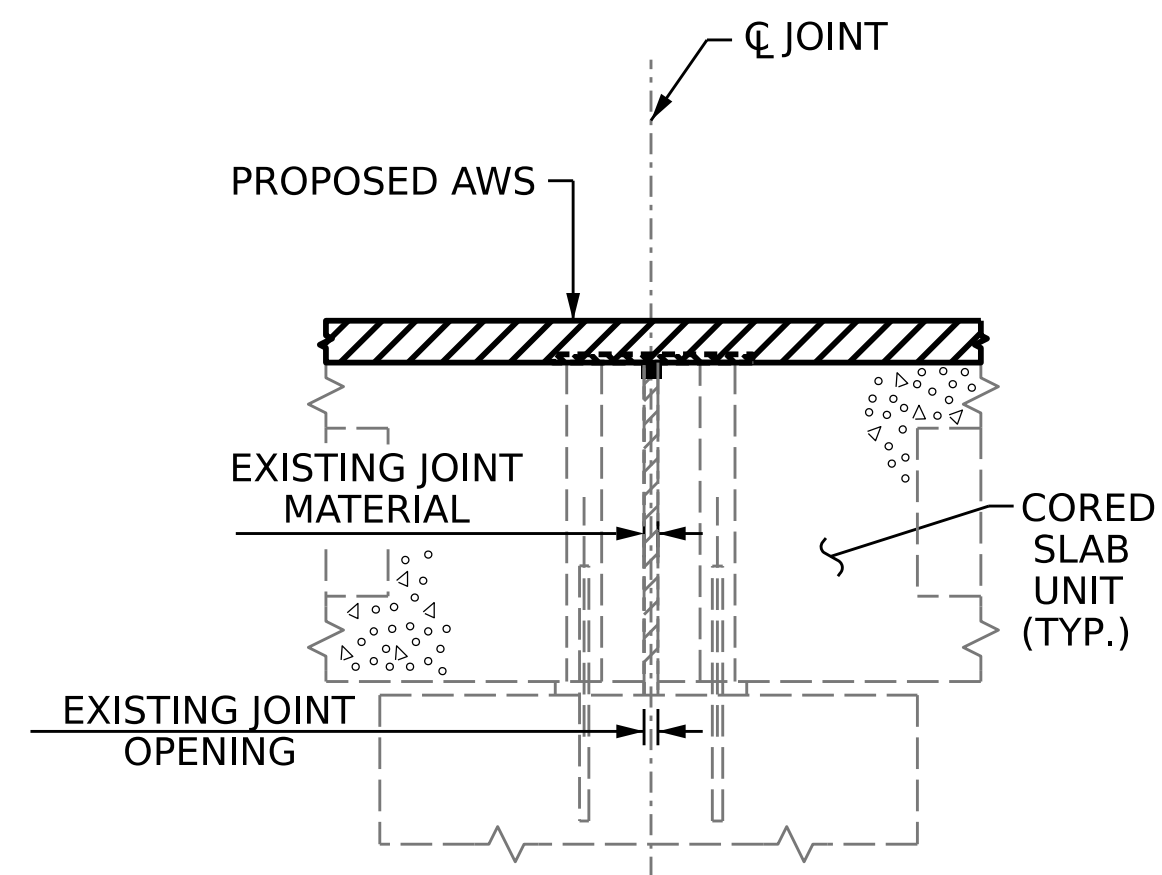

EXISTING JOINT  
(AFTER PROPOSED AWS IS PLACED)

**EXISTING JOINT DETAILS AT BENTS**

SECTION B-B

PROJECT NO. HI-0017  
ROBESON COUNTY  
 BRIDGE NO. 770454



STATE OF NORTH CAROLINA  
 DEPARTMENT OF TRANSPORTATION  
 RALEIGH

**EXISTING JOINT  
 DETAILS**

DRAWN BY : J. BALDWIN DATE : 07/2022  
 CHECKED BY : S. WANCE DATE : 11/2022

DOCUMENT NOT CONSIDERED  
 FINAL UNLESS ALL  
 SIGNATURES COMPLETED

REVISIONS						SHEET NO.
NO.	BY:	DATE:	NO.	BY:	DATE:	S4-5
1			3			TOTAL SHEETS
2			4			7