

JOINT INSTALLATION SEQUENCE AT END BENTS

SECTION A-A

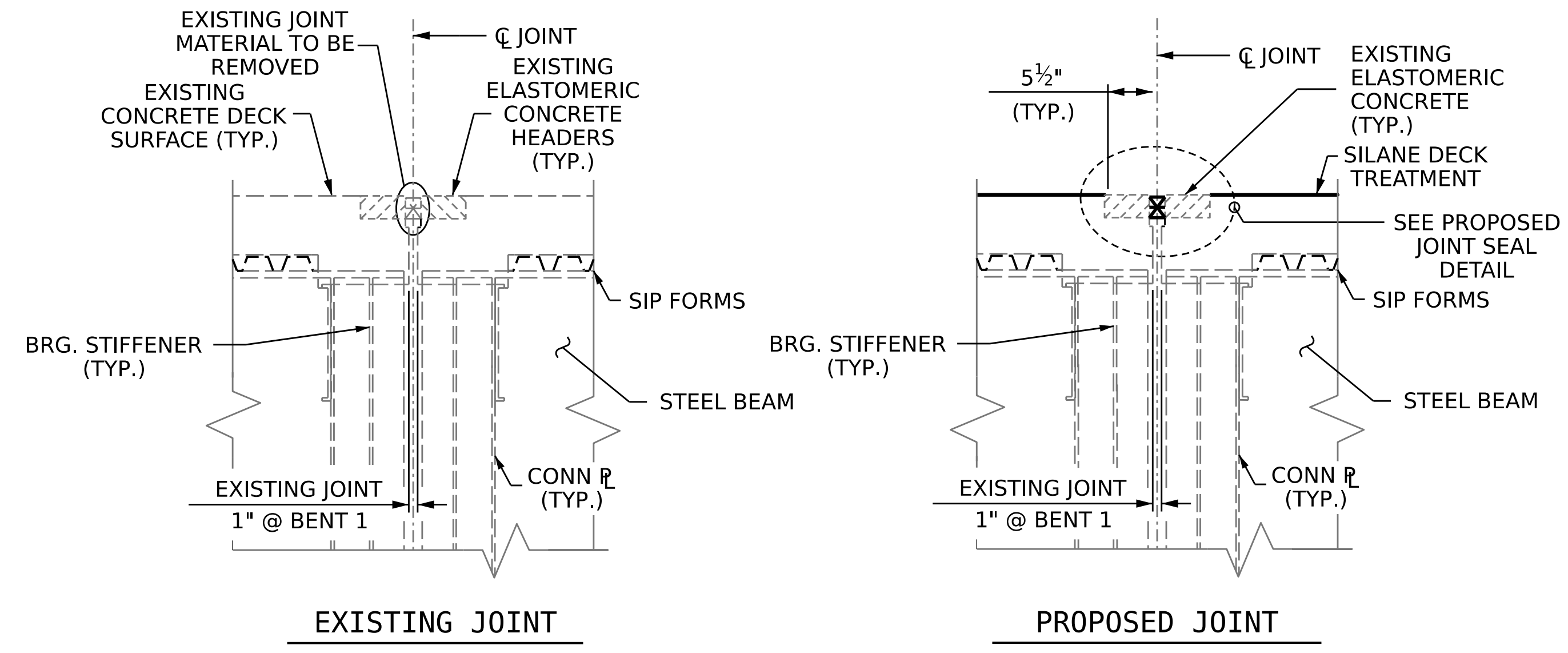

JOINT INSTALLATION SEQUENCE AT BENT

SECTION B-B

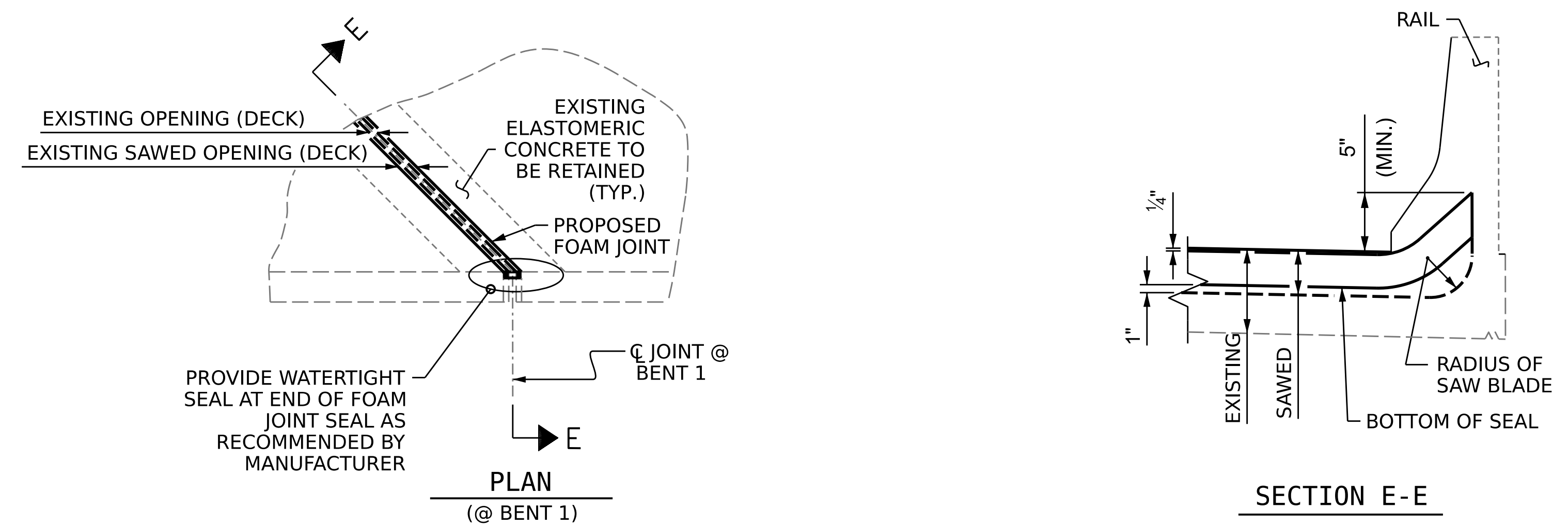

JOINT DETAIL AT BARRIER RAIL

NOTES

FINAL JOINT SEALS SHALL NOT BE INSTALLED UNTIL THE OVERLAY OR SEALANT WORK IS COMPLETE.

CONTRACTOR SHALL FIELD VERIFY THE EXISTING FORMED OPENING PRIOR TO OBTAINING JOINT MATERIAL. IF ACTUAL JOINT OPENINGS Varies FROM THE OPENING INDICATED IN DETAIL MORE THAN 1/4", NOTIFY THE ENGINEER. REVISION TO THE JOINT SEAL SIZE MAY BE NECESSARY.

THE MANUFACTURER IS TO PROVIDE THE NOMINAL UNCOMPRESSED SEAL WIDTH OF THE FOAM JOINT SEAL FOR THE SIZE OF THE OPENING ON THE PLANS AND ACCOMMODATE THE MINIMUM EXPANSION SHOWN ON THE PLANS.

FOAM JOINTS SHALL BE INSTALLED AS PER THE MANUFACTURER'S RECOMMENDATIONS.

THE CONTRACTOR SHALL TAKE CARE DURING JOINT REHAB OPERATIONS NOT TO DROP ANY MATERIAL BELOW THE BRIDGE WITHOUT PROTECTIVE DEVICES BELOW TO CATCH THE MATERIAL. ANY MATERIAL THAT FALLS BELOW THE BRIDGE SHALL BE CONTAINED, REMOVED AND DISPOSED OF BY THE CONTRACTOR AT NO EXTRA COST TO THE DEPARTMENT. IF THE ENGINEER DETERMINES THAT THE PROTECTIVE DEVICES ARE NOT ADEQUATE OR NOT BEING EMPLOYED, THE WORK SHALL BE SUSPENDED UNTIL ADEQUATE PROTECTION IS PROVIDED.

UNLESS NOTED OTHERWISE RETAIN ALL EXISTING REINFORCING STEEL. CLEAN AND REPAIR AS NEEDED.

ALL EXPOSED ENDS OF CUT BARS SHALL BE COATED WITH EPOXY PRIOR TO THE NEW JOINT MATERIAL INSTALLATION.

THE CONTRACTOR WILL NOT BE PERMITTED TO FORM THE JOINTS IN LIEU OF SAWING THE JOINT.

THE INSTALLED FOAM JOINTS SHALL BE WATERTIGHT.

FOR FOAM EXPANSION JOINT SEALS FOR PRESERVATION, SEE SPECIAL PROVISIONS.

DURING JOINT INSTALLATION PROCEDURE, THE JOINT AND SURROUNDING AREA SHALL BE KEPT CLEAN AND FREE OF DEBRIS.

QUANTITIES SHOWN IN THE SUMMARY OF QUANTITIES TABLE ARE BASED ON THE MINIMUM JOINT DEMOLITION SHOWN.

FOR EXCAVATION BELOW THE BOTTOM OF THE PLANNED JOINT DEMOLITION, CONCRETE FOR DECK REPAIR SHALL BE PLACED IN THE EXCAVATED AREA TO THE ELEVATION AT BOTTOM OF THE PROPOSED ELASTOMERIC CONCRETE FOR PRESERVATION HEADERS SHOWN.

FINAL SURFACE OF THE JOINT DEMOLITION AREA PRIOR TO PLACEMENT OF CONCRETE REPAIR MATERIAL OR ELASTOMERIC CONCRETE SHOULD BE REASONABLY FLAT AND LEVEL. ENGINEER SHALL DETERMINE THE ACCEPTABILITY OF THE SURFACE PRIOR TO PLACEMENT OF REPAIR CONCRETE OR ELASTOMERIC CONCRETE.

FOR BRIDGE JOINT DEMOLITION, SEE SPECIAL PROVISIONS.

FOR ELASTOMERIC CONCRETE FOR PRESERVATION, SEE SPECIAL PROVISIONS.

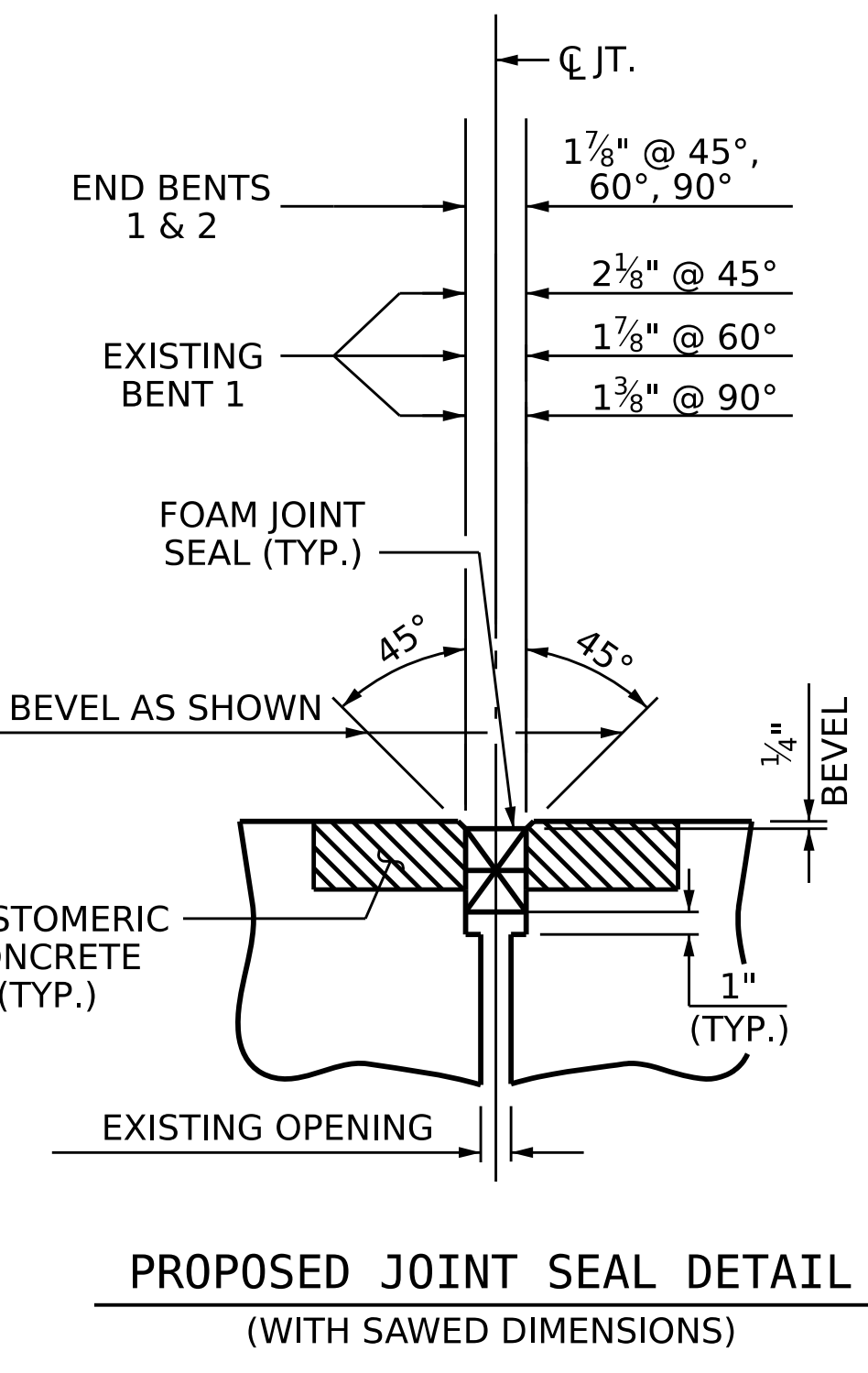

SUMMARY OF QUANTITIES		
	ESTIMATE	ACTUAL
ELASTOMERIC CONCRETE FOR PRESERVATION	12.9 CF	
FOAM JOINT SEALS FOR PRESERVATION	113.1 LF	

PROJECT NO. **HI-0017**
ROBESON COUNTY
 BRIDGE NO. **770447**

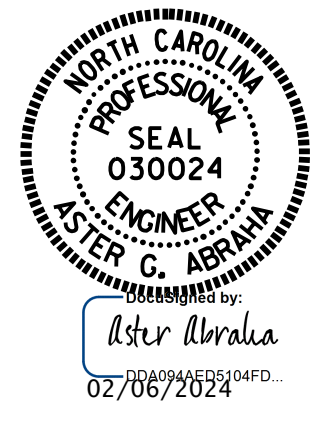

STATE OF NORTH CAROLINA
 DEPARTMENT OF TRANSPORTATION
 RALEIGH

JOINT REPAIR DETAILS

DRAWN BY : J. BALDWIN DATE : 9/2022
 CHECKED BY : G. AYES DATE : 11/2022
 DESIGN ENGINEER OF RECORD: DATE :

DOCUMENT NOT CONSIDERED FINAL UNLESS ALL SIGNATURES COMPLETED

REVISIONS						SHEET NO.
NO.	BY:	DATE:	NO.	BY:	DATE:	S1-4
1			3			TOTAL SHEETS
2			4			6