

PLAN OF DRILLED PIERS & COLUMNS

REINFORCING STEEL, DIMENSIONS AND DETAILS ARE TYPICAL FOR EACH COLUMN AND DRILLED PIER

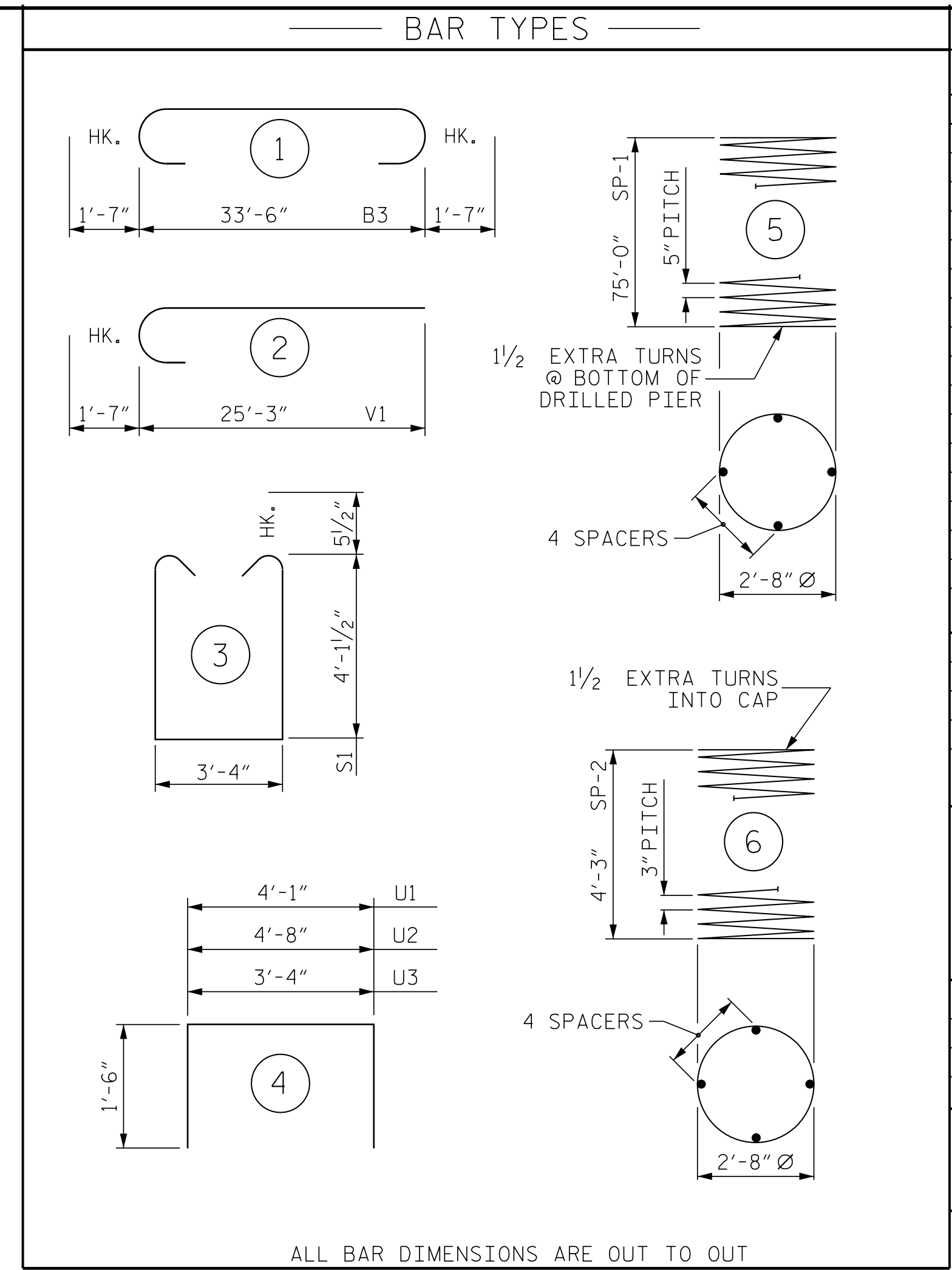

ALL BAR DIMENSIONS ARE OUT TO OUT

BILL OF MATERIAL					
BENT NO. 1					
BAR	NO.	SIZE	TYPE	LENGTH	WEIGHT
B1	7	#11	STR	33'-6"	1246
B2	12	#4	STR	33'-6"	269
B3	7	#11	1	36'-8"	1364
B4	7	#4	STR	11'-0"	51
M1	48	#11	STR	42'-11"	10,945
M2	24	#11	STR	60'-0"	7651
S1	44	#5	3	12'-6"	574
U1	5	#4	4	7'-1"	24
U2	5	#4	4	7'-8"	26
U3	49	#4	4	6'-4"	207
V1	24	#11	2	30'-9"	3921
REINFORCING STEEL					26,278 LBS.
SP-1	3	**	5	1496'-11"	4684
SP-2	3	*	6	156'-10"	314
SPIRAL COLUMN REINFORCING STEEL					4,998 LBS.
** THE SP-1 SPIRAL REINFORCING STEEL SHALL BE W31 OR D-31 COLD DRAWN WIRE OR #5 PLAIN OR DEFORMED BAR					
* THE SP-2 SPIRAL REINFORCING STEEL SHALL BE W20 OR D-20 COLD DRAWN WIRE OR #4 PLAIN OR DEFORMED BAR					
CLASS A CONCRETE BREAKDOWN					
POUR #2 (COLUMNS)					3.1 C.Y.
POUR #3 (CAP)					21.9 C.Y.
TOTAL CLASS A CONCRETE					25.0 C.Y.
DRILLED PIERS:					
DRILLED PIER CONCRETE POUR #1 (DRILLED PIERS)					80.7 C.Y.

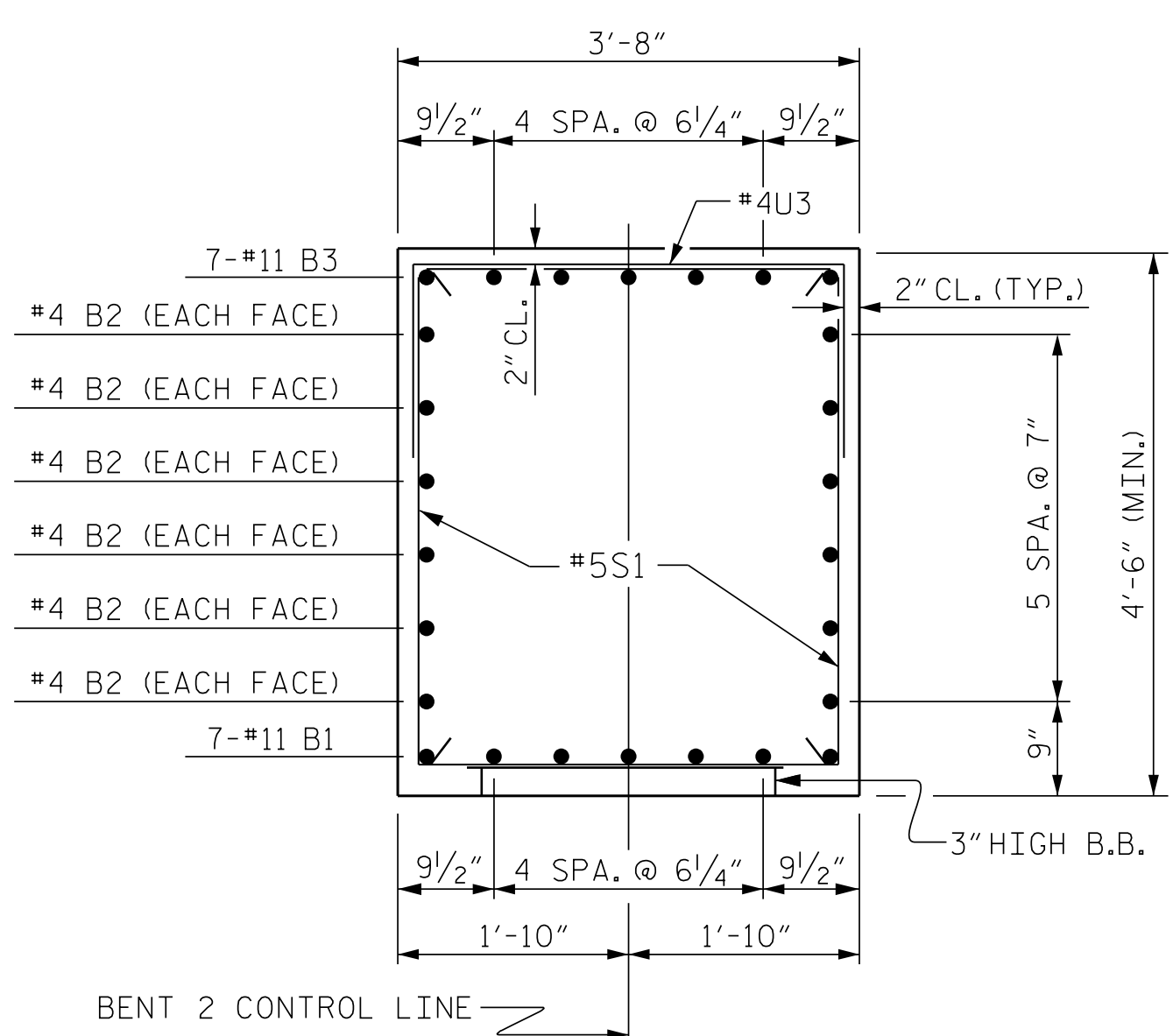

SECTION A-A

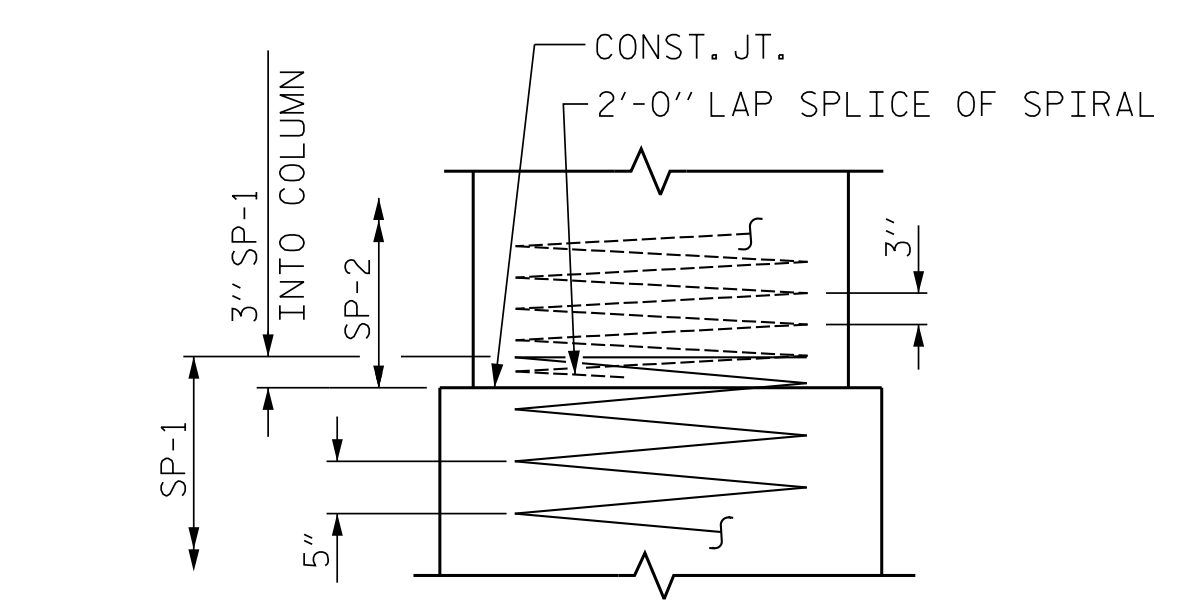

CONSTRUCTION JOINT DETAIL

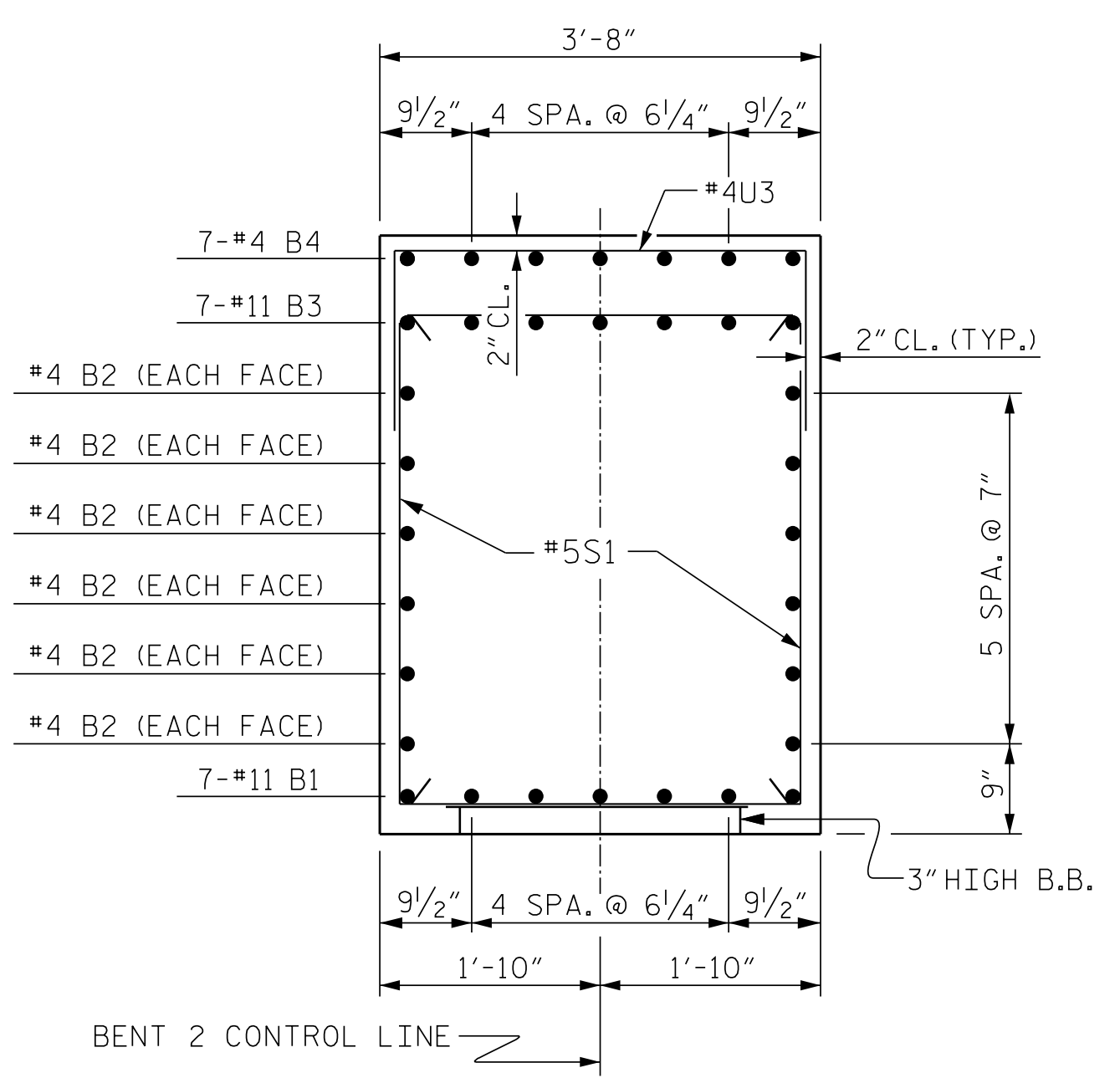

SECTION B-B

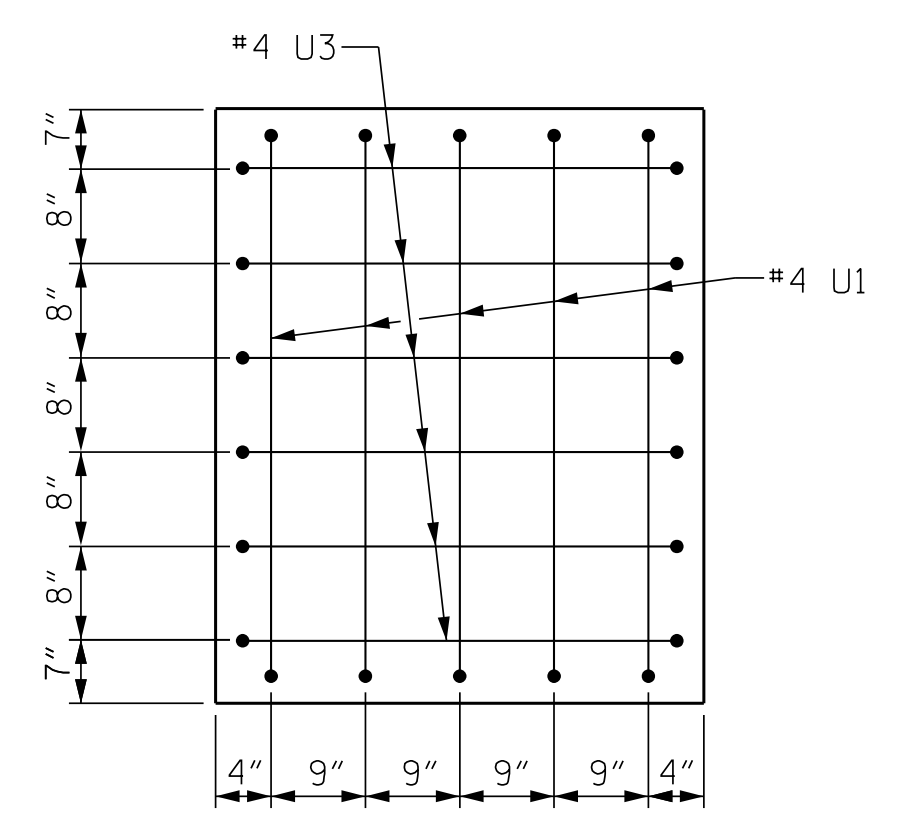

LEFT END OF CAP

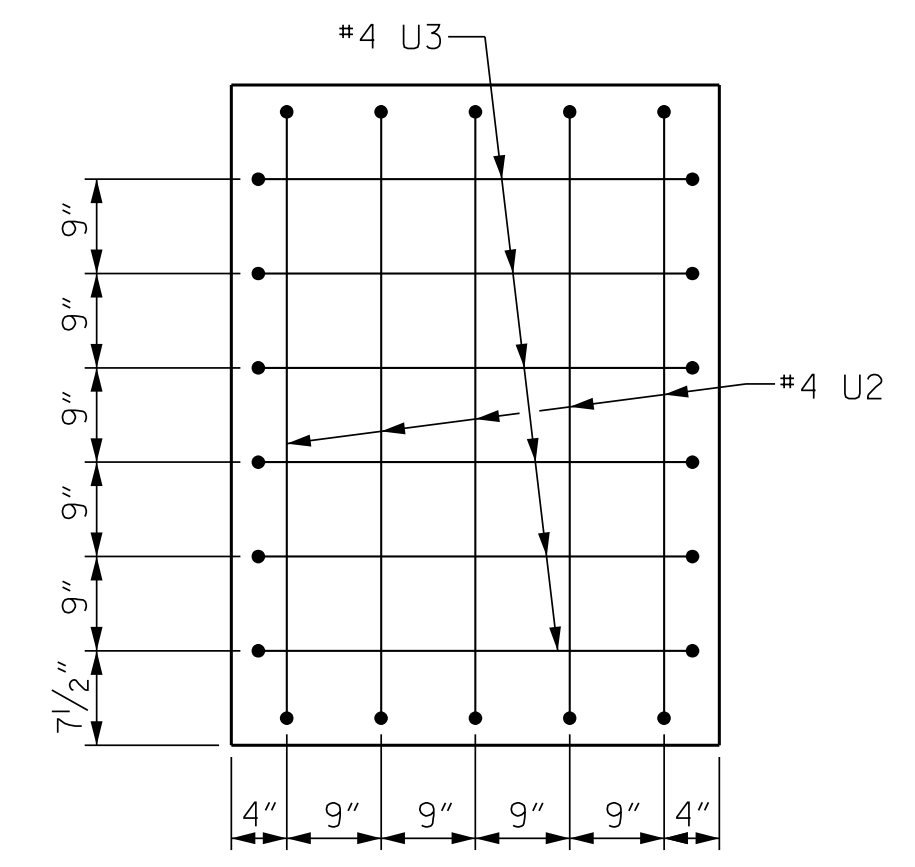

RIGHT END OF CAP

PROJECT NO. B-4926
LENOIR COUNTY
 STATION: 35+00.00 -L-
 SHEET 2 OF 2

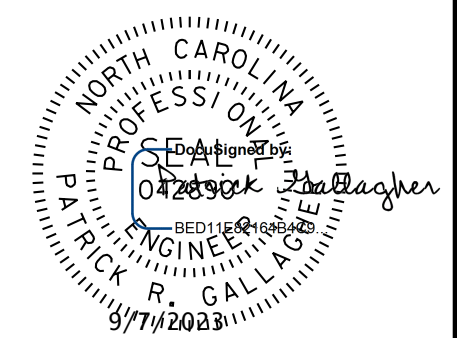

STATE OF NORTH CAROLINA
 DEPARTMENT OF TRANSPORTATION
 RALEIGH
 SUBSTRUCTURE
 BENT NO. 1

DOCUMENT NOT CONSIDERED FINAL UNLESS ALL SIGNATURES COMPLETED
 Johnson, Mirmiran, & Thompson Inc.
 4700 Falls of Neuse Rd, Suite 100,
 Raleigh, NC, 27609
 License No: C-3097

REVISIONS					
NO.	BY:	DATE:	NO.	BY:	DATE:
1			3		
2			4		

DWN. BY: WDC DATE: 03/2023
 CHKD. BY: PRG DATE: 03/2023
 DES. EGR. OF RECORD: PRG DATE: 03/2023

SHEET NO. S2-31
 TOTAL SHEETS 39

W:\Projects\2023\Bent No. 1\Bent No. 1.dwg
 03/23/2023 10:23:34 AM on Wednesday
 03/23/2023 10:23:34 AM on Wednesday