

-L- STA. 16+48± BEGIN PCB
OFFSET 11' L

-L- STA. 20+21± END PCB
OFFSET 13' L

-L- STA. 19+00±
20'

BEGIN TIP PROJECT B-4926
-L- STA. 15+00.00

MATCHLINE -L- STA. 29+00.00
SEE TMP-7

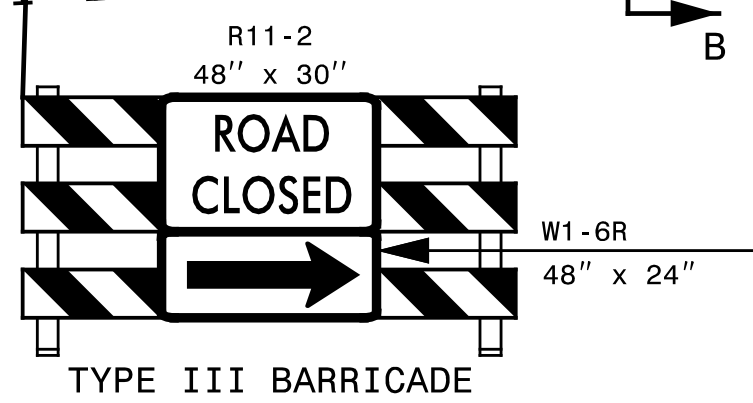

A-A -L- STA. 19+00

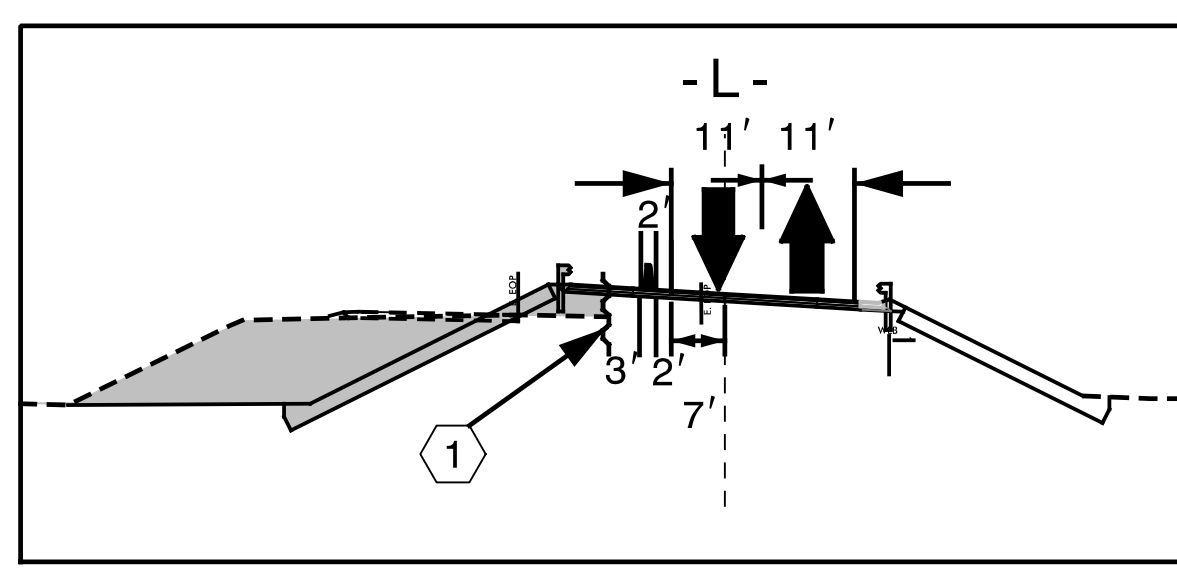

B-B -L- STA. 22+75

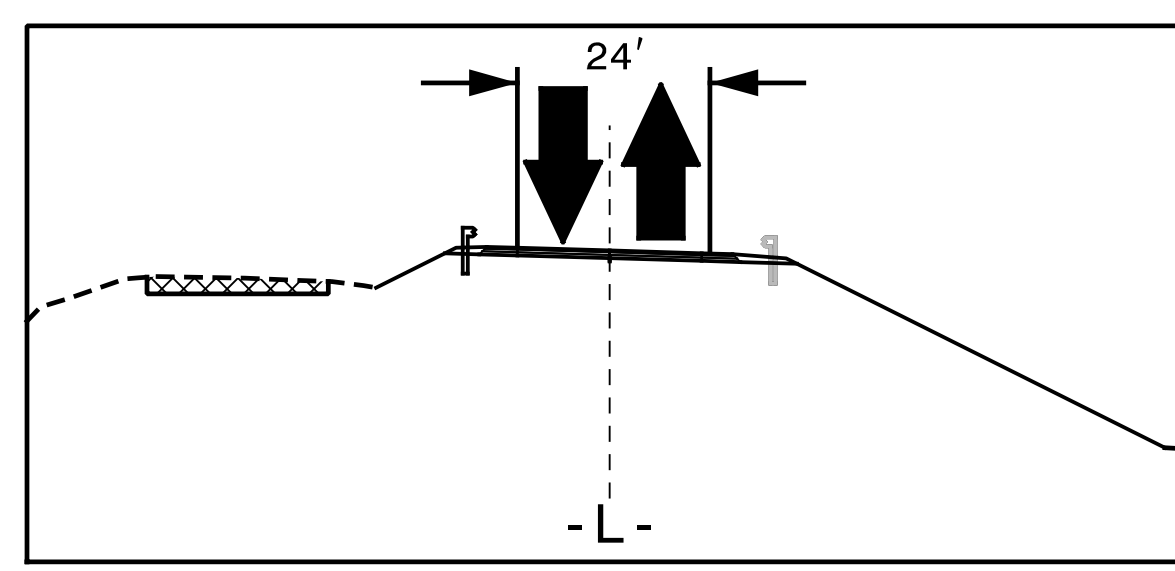

C-C -L- STA. 28+15

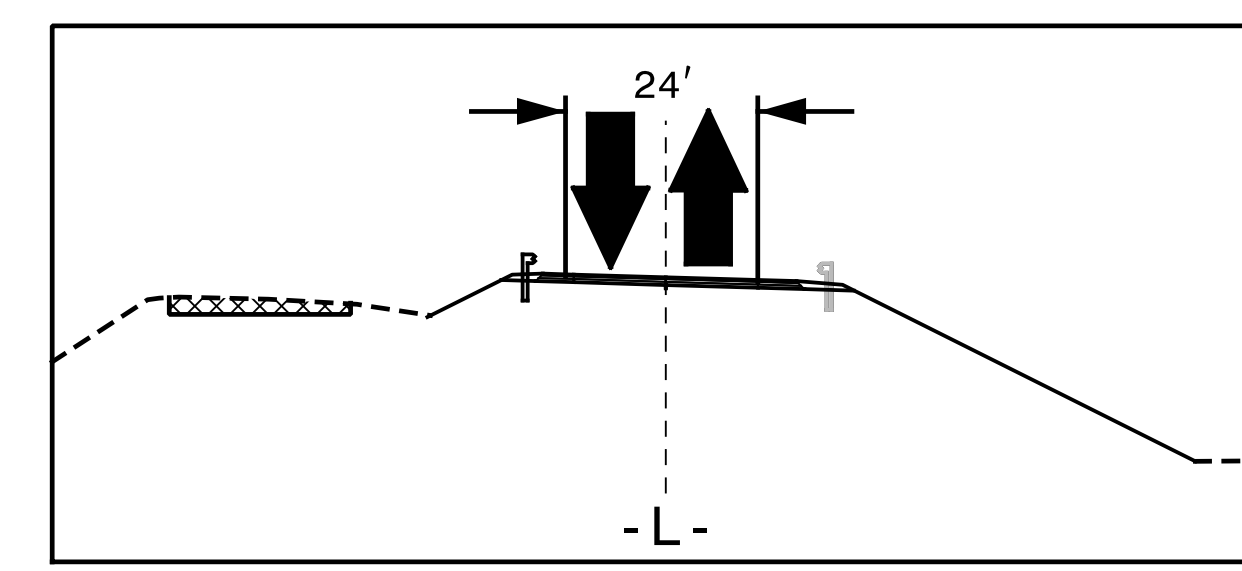

4/4/2004
C:\08\SEB\015.00.B-4926.TP\Traffic\TMP\B-4926.TMP-6.dgn
db

TRANSYSTEMS
1 Glenwood Avenue
Raleigh, NC 27603
Tel: 919.789.9977
Fax: 919.789.9591
License: F-0453

APPROVED: Steve Miller
DATE: _____
SEAL
NORTH CAROLINA PROFESSIONAL ENGINEER
SEAL 037026
STEVEN D. MILLER

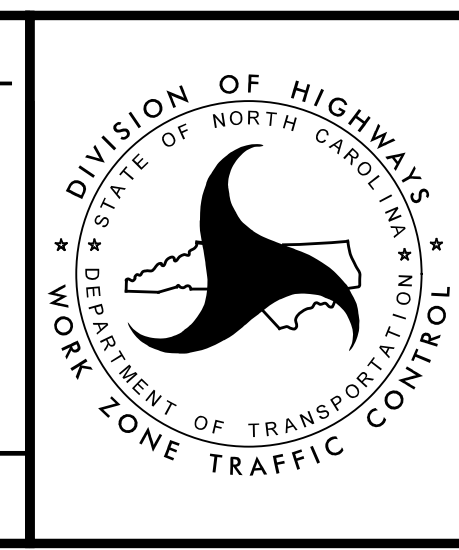

PHASE II

DOCUMENT NOT CONSIDERED FINAL
UNLESS ALL SIGNATURES COMPLETED