

① TEMPORARY SHORING TO REMAIN IN PLACE -L- STA. 17+50 OFF 12' L TO -L- STA. 21+20 OFF 19' L
 AVERAGE HEIGHT: 4', QUANTITY = 1480 SF

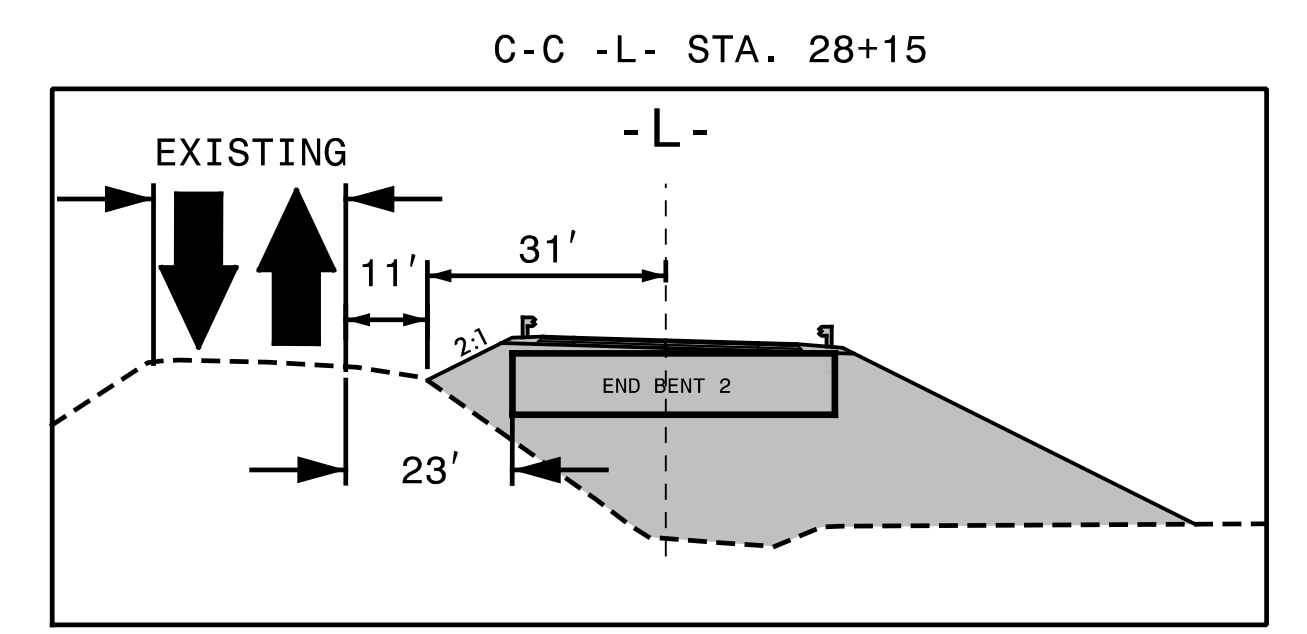
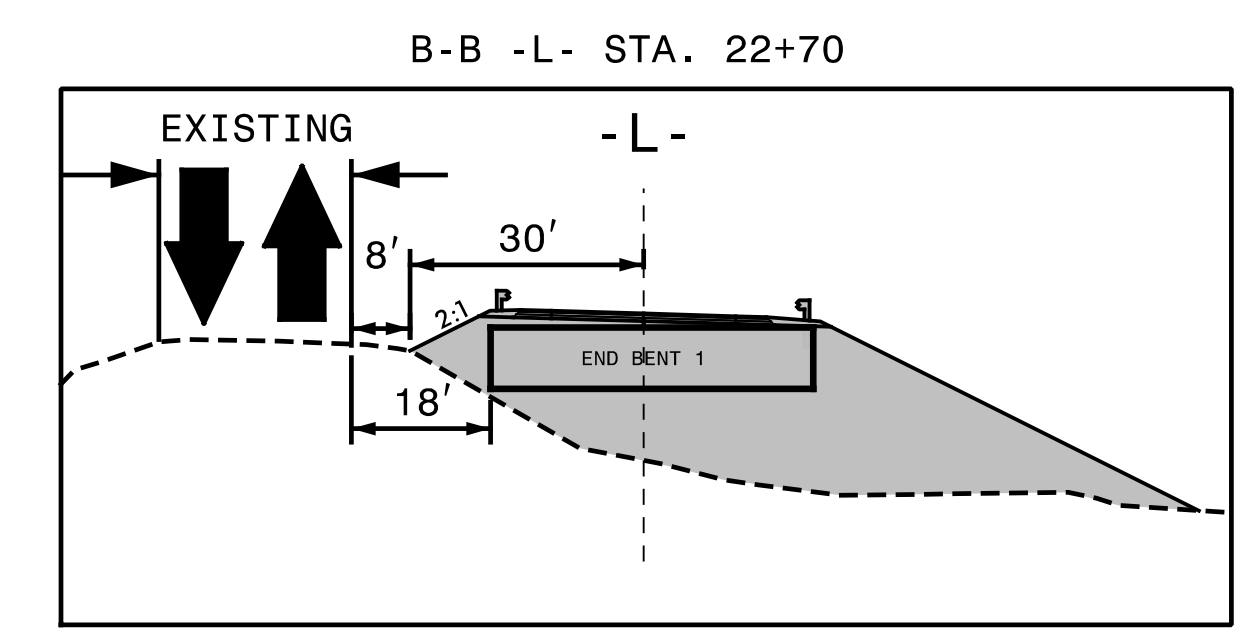
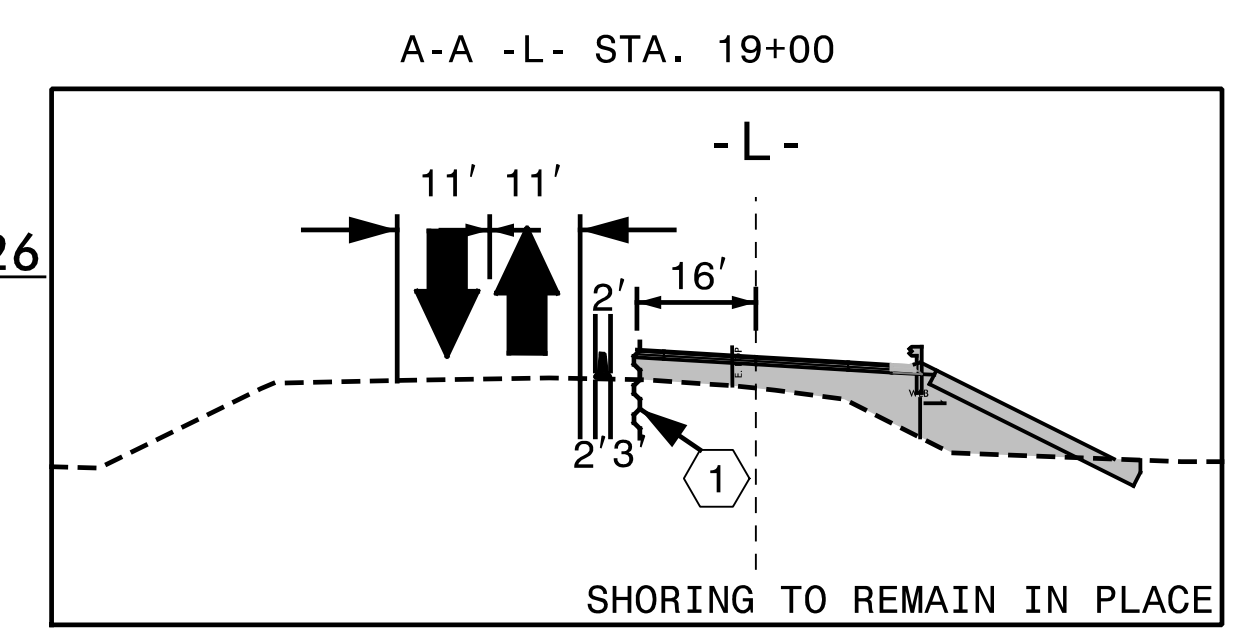
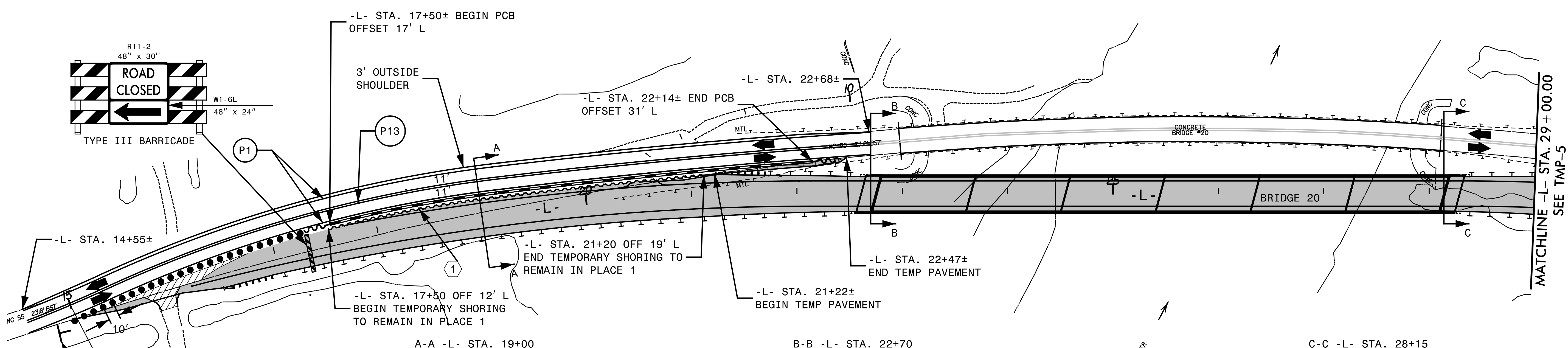
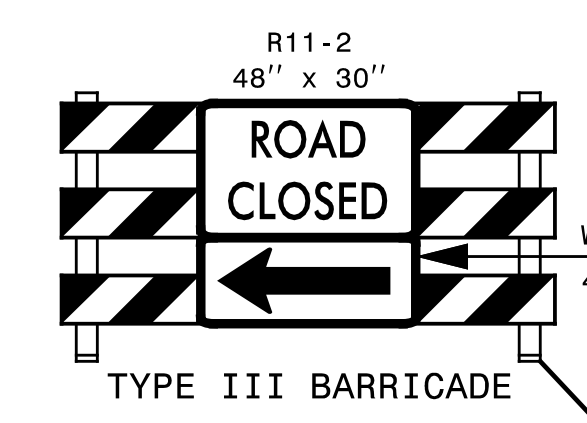
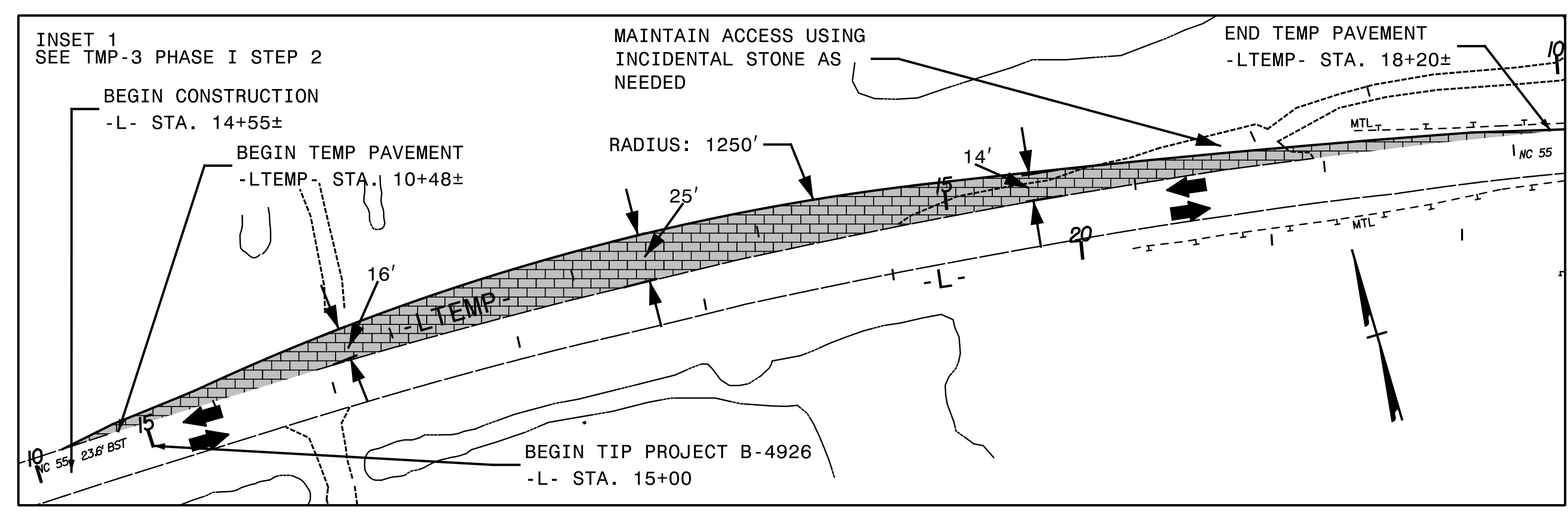

4/15/2024 10:08:08 AM S:\E\B\015.00.B-4926\TP\Traffic\TMP\B-4926-TMP-4.dgn

APPROVED: Steve Miller
DocuSigned by: Steve Miller 9f80c15cceb486

DATE: _____

SEAL

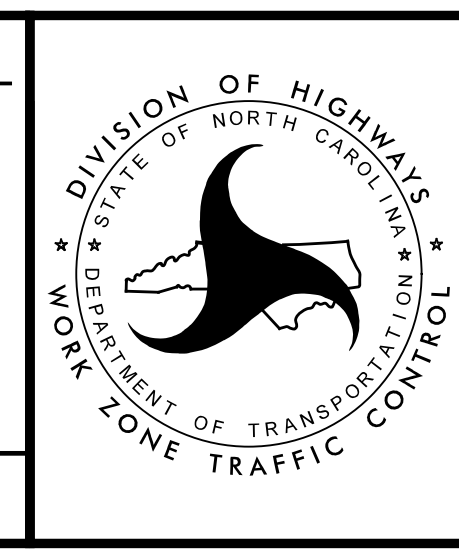

PHASE I

TRANSYSTEMS

1 Glenwood Avenue
 Raleigh, NC 27603
 Tel: 919.789.9977
 Fax: 919.789.9591
 License: F-0453

**DOCUMENT NOT CONSIDERED FINAL
 UNLESS ALL SIGNATURES COMPLETED**