

T.I.P.: R-2577A

CONTRACT: C204913

STATE OF NORTH CAROLINA
DEPARTMENT OF TRANSPORTATION

PAVEMENT MARKING PLAN
FORSYTH COUNTY

LOCATION: US 158 (REIDSVILLE RD.) FROM NORTH OF
US 421/40 BUS. TO SR 1965 (BELEWS CREEK RD.)

PROJECT REFERENCE NO. R-2577A SHEET NO. PMP-1
APPROVED: David T. Sears DATE: 3/7/2024
SEAL: NORTH CAROLINA PROFESSIONAL ENGINEER SEAL 044558 DAVID T. SEARS
DOCUMENT NOT CONSIDERED FINAL UNLESS ALL SIGNATURES COMPLETED

ROADWAY STANDARD DRAWINGS

THE FOLLOWING ROADWAY STANDARDS AS APPEAR IN "ROADWAY STANDARD DRAWINGS" - PROJECT SERVICES UNIT - N.C. DEPARTMENT OF TRANSPORTATION - RALEIGH, N.C., DATED JANUARY 2024 ARE APPLICABLE TO THIS PROJECT AND BY REFERENCE HEREBY ARE CONSIDERED A PART OF THESE PLANS:

Table with 2 columns: STD. NO. and TITLE. Lists various pavement marking standards such as line types, intersections, turn lanes, etc.

PAVEMENT MARKING SCHEDULE

Table with 2 columns: THERMOPLASTIC LINES and THERMOPLASTIC SYMBOLS. Lists specific marking types and symbols like T1 White Edgeline, T70 Left Turn Arrow, etc.

GENERAL NOTES

THE FOLLOWING GENERAL NOTES APPLY AT ALL TIMES FOR THE DURATION OF THE CONSTRUCTION PROJECT, EXCEPT WHEN OTHERWISE NOTED IN THE PLAN, OR DIRECTED BY THE ENGINEER.

- A) INSTALL PAVEMENT MARKINGS AND PAVEMENT MARKERS ON THE FINAL SURFACE AS FOLLOWS:
ROAD NAME MARKING MARKER
-L- THERMOPLASTIC SNOWPLOWABLE
-Y1A-, -Y1B-, -Y5-, -Y10-, -Y20- THERMOPLASTIC PERMANENT RAISED
CONCRETE SURFACES COLD APPLIED PLASTIC PERMANENT RAISED
OTHER -Y- LINES THERMOPLASTIC NONE
B) TIE PROPOSED PAVEMENT MARKING LINES TO EXISTING PAVEMENT MARKING LINES.
C) REMOVE/REPLACE ANY CONFLICTING/DAMAGED PAVEMENT MARKINGS AND MARKERS.
D) STOP BAR LOCATION AT NON-SIGNALIZED INTERSECTIONS MAY BE ADJUSTED AS DIRECTED BY THE ENGINEER.
E) REMOVE ALL RESIDUE AND SURFACE LAITANCE BY ACCEPTABLE METHODS ON CONCRETE BRIDGE DECKS PRIOR TO PLACING (COLD APPLIED PLASTIC) PAVEMENT MARKING MATERIAL.
F) SEE ROADWAY PLANS FOR ALTERNATE CURB RAMP DESIGNS WHEN INDICATED ON PAVEMENT MARKING DETAIL SHEETS.

INDEX

Table with 2 columns: SHEET NO. and DESCRIPTION. Lists PMP-1 Pavement Marking Plan Title and Schedule Sheet, and PMP-2-27 Pavement Marking Detail.

PLAN PREPARED FOR: N.C.D.O.T. SIGNING AND DELINEATION UNIT

ERIC WARD SIGNING & DELINEATION DESIGN ENGINEER
K. L. JORDAN SIGNING & DELINEATION REGIONAL ENGINEER

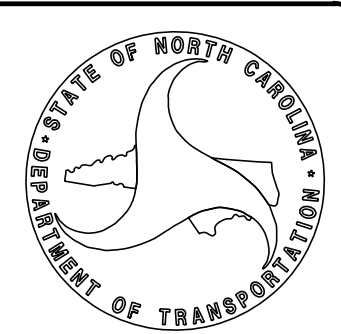

PLAN PREPARED BY: RK&K

David Sears, PE, PTOE Project Engineer
Allen Tutt Sr. Designer



P: (919) 878-9560
8601 Six Forks Road, Forum 1, Suite 700
Raleigh, North Carolina 27615-3960
NC License No. F-0112

Engineers | Construction Managers | Planners | Scientists
www.rkk.com

Responsive People | Creative Solutions

PROJECT REFERENCE NO.	SHEET NO.
R-2577A	PMP-2
APPROVED: <i>David T. Sears</i>	
DATE: 3/7/2024	
SEAL	
	
DOCUMENT NOT CONSIDERED FINAL UNLESS ALL SIGNATURES COMPLETED	

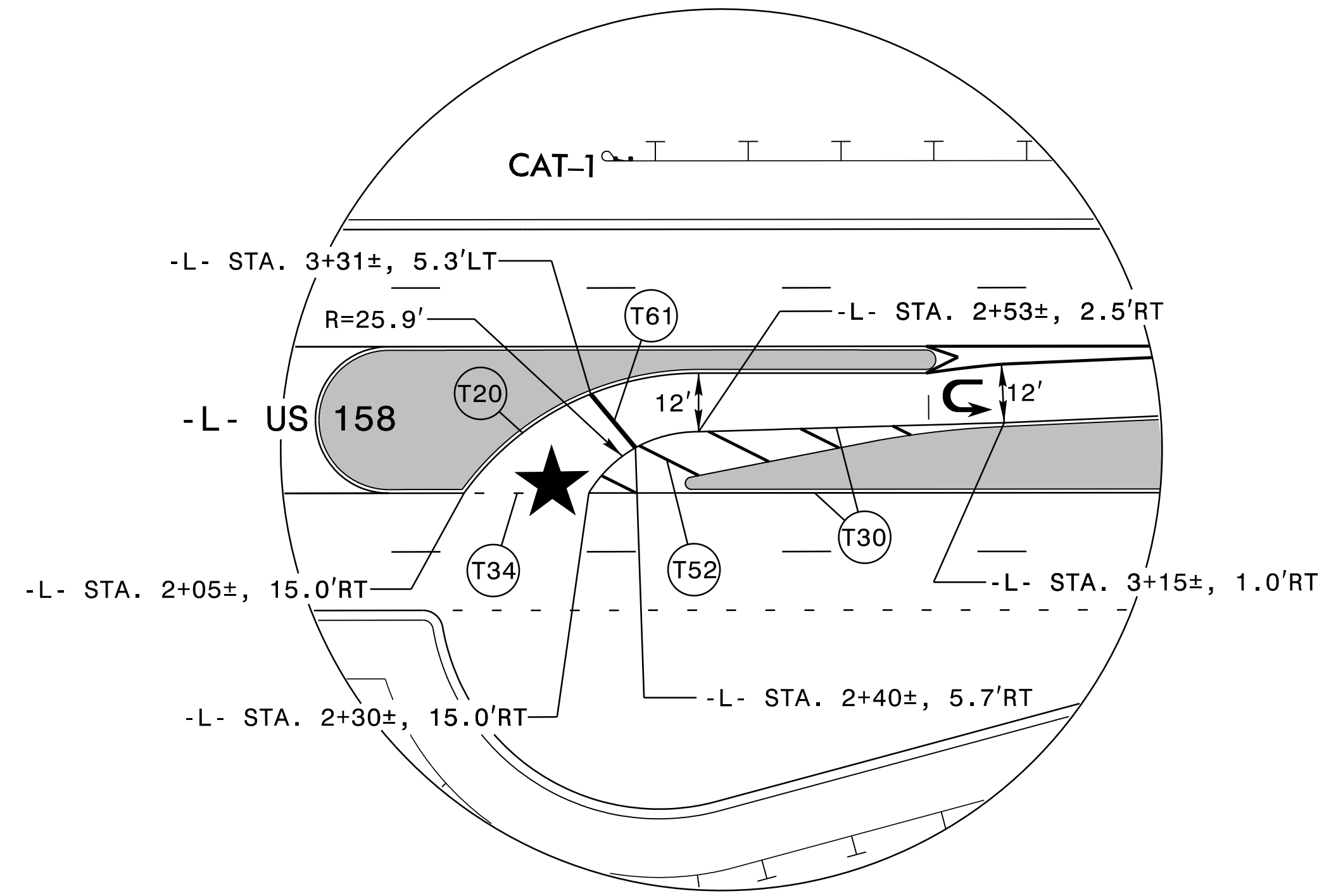

INSET

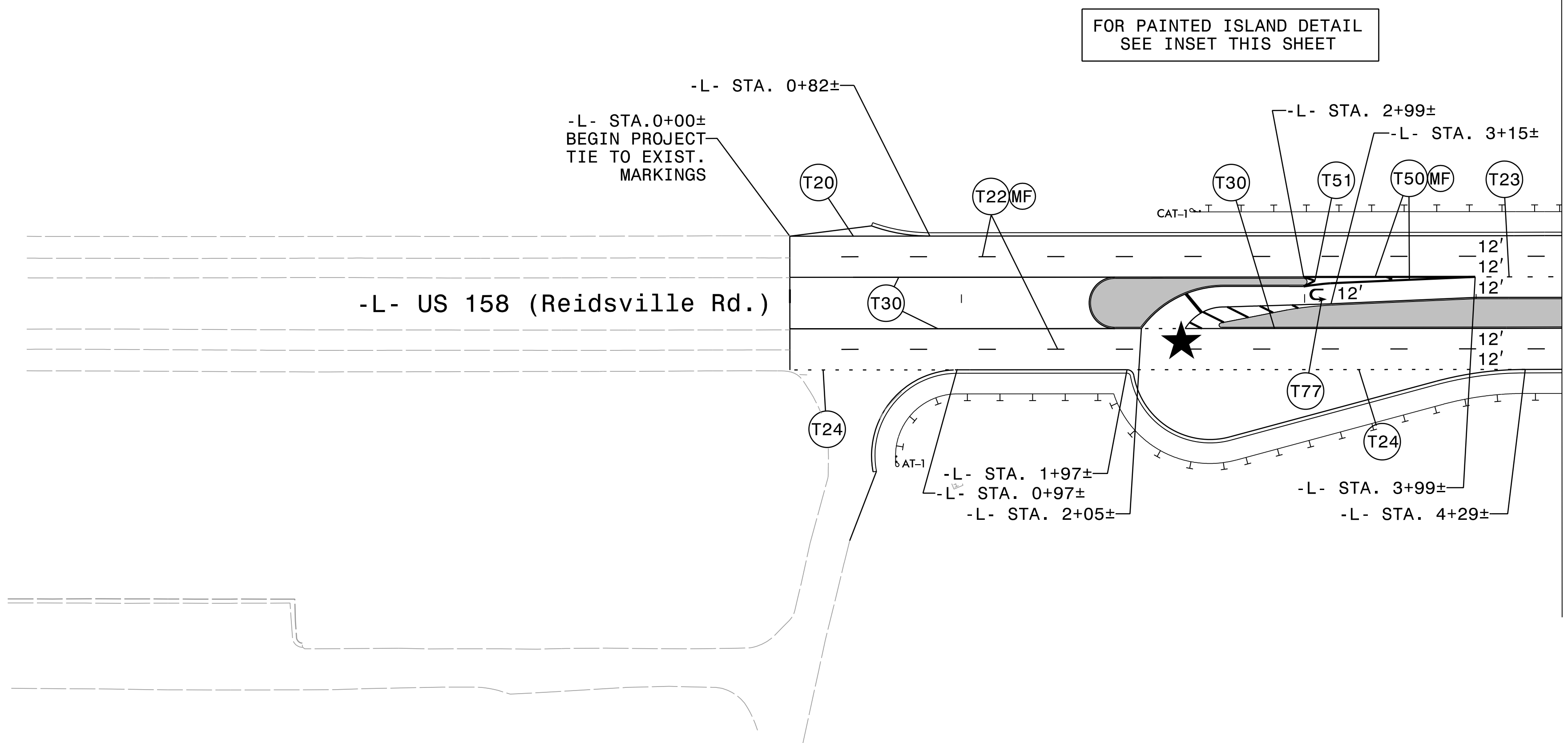

★ SIGNALIZED INTERSECTION

PAVEMENT MARKING DETAIL

RK&K
 P: (919) 878-9550
 6601 Six Forks Road, Forum 1, Suite 700
 Raleigh, North Carolina 27615-3960
 NC License No. F-0112
 Engineers | Construction Managers | Planners | Scientists
 www.rkk.com
 Responsive People | Creative Solutions

R:\2024\2577A_PMP-2.dgn

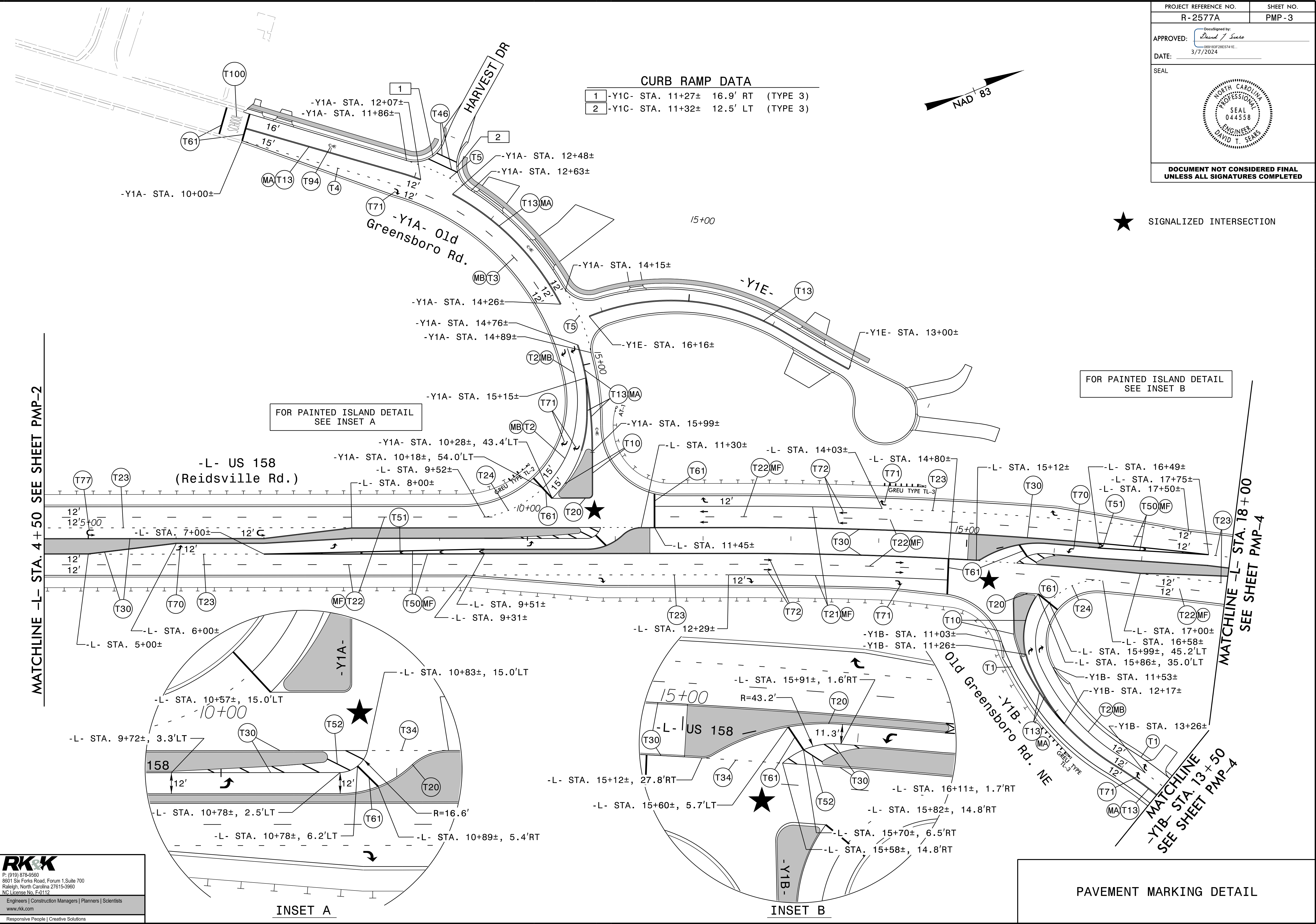

CURB RAMP DATA

1	-Y1C- STA. 11+27±	16.9' RT	(TYPE 3)
2	-Y1C- STA. 11+32±	12.5' LT	(TYPE 3)

★ SIGNALIZED INTERSECTION

FOR PAINTED ISLAND DETAIL
SEE INSET B

FOR PAINTED ISLAND DETAIL
SEE INSET A

MATCHLINE -L- STA. 4 + 50 SEE SHEET PMP-2

MATCHLINE -L- STA. 18 + 00
SEE SHEET PMP-4

MATCHLINE -Y1B- STA. 13 + 50
SEE SHEET PMP-4

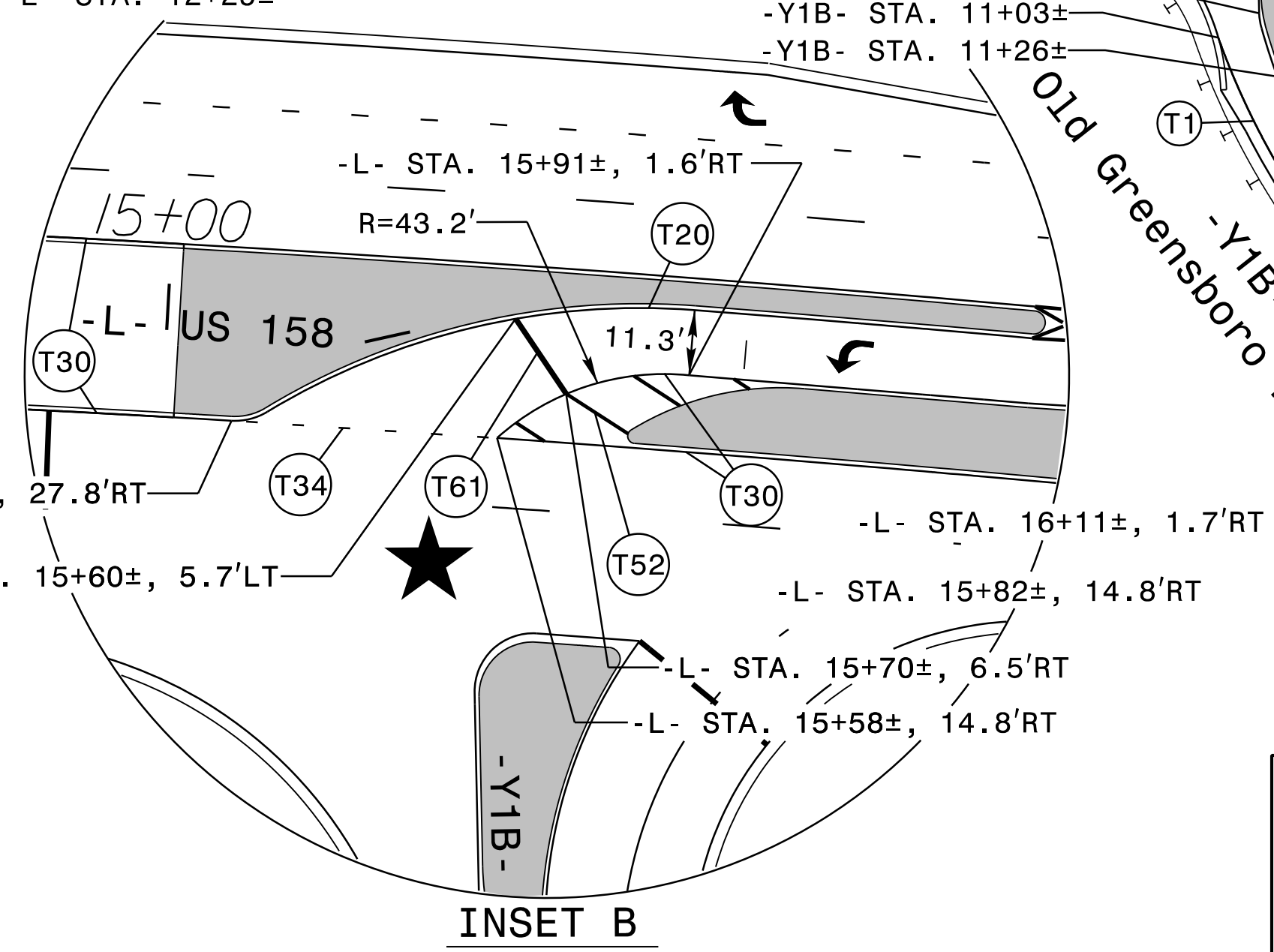
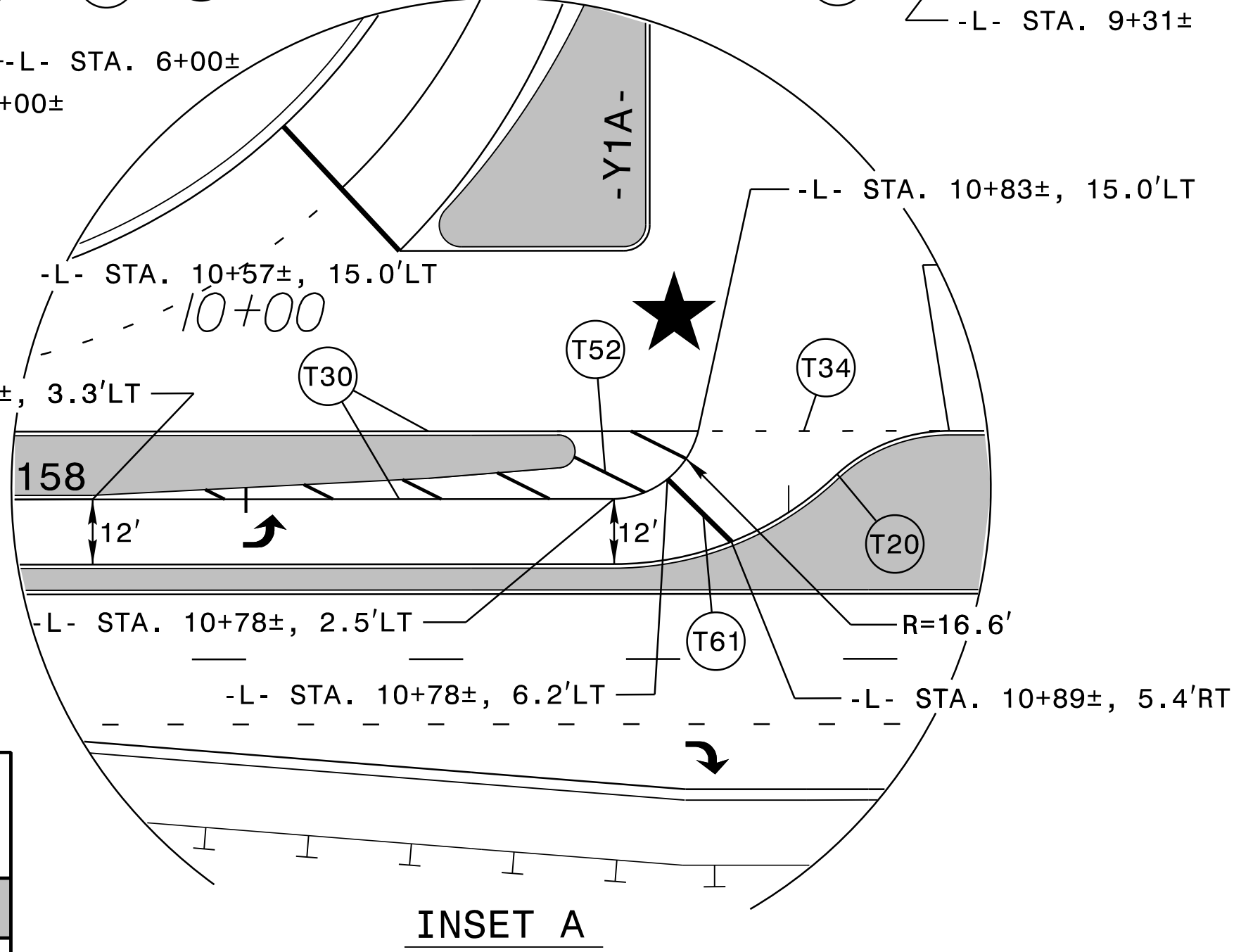

PAVEMENT MARKING DETAIL

PROJECT REFERENCE NO. R-2577A	SHEET NO. PMP-4
APPROVED: <i>David T. Sears</i> 089183F28E5741E 3/7/2024	
SEAL 	
DOCUMENT NOT CONSIDERED FINAL UNLESS ALL SIGNATURES COMPLETED	

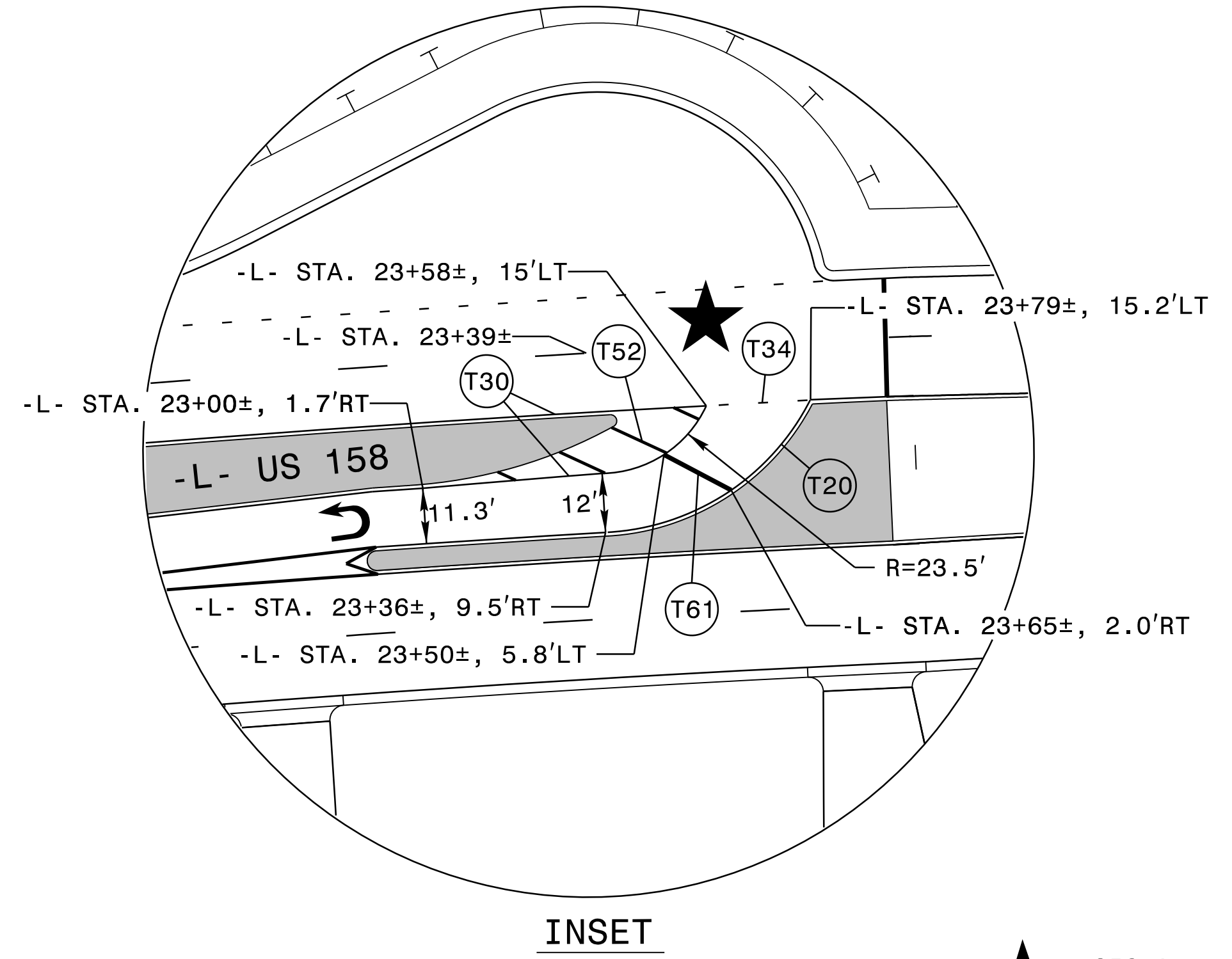
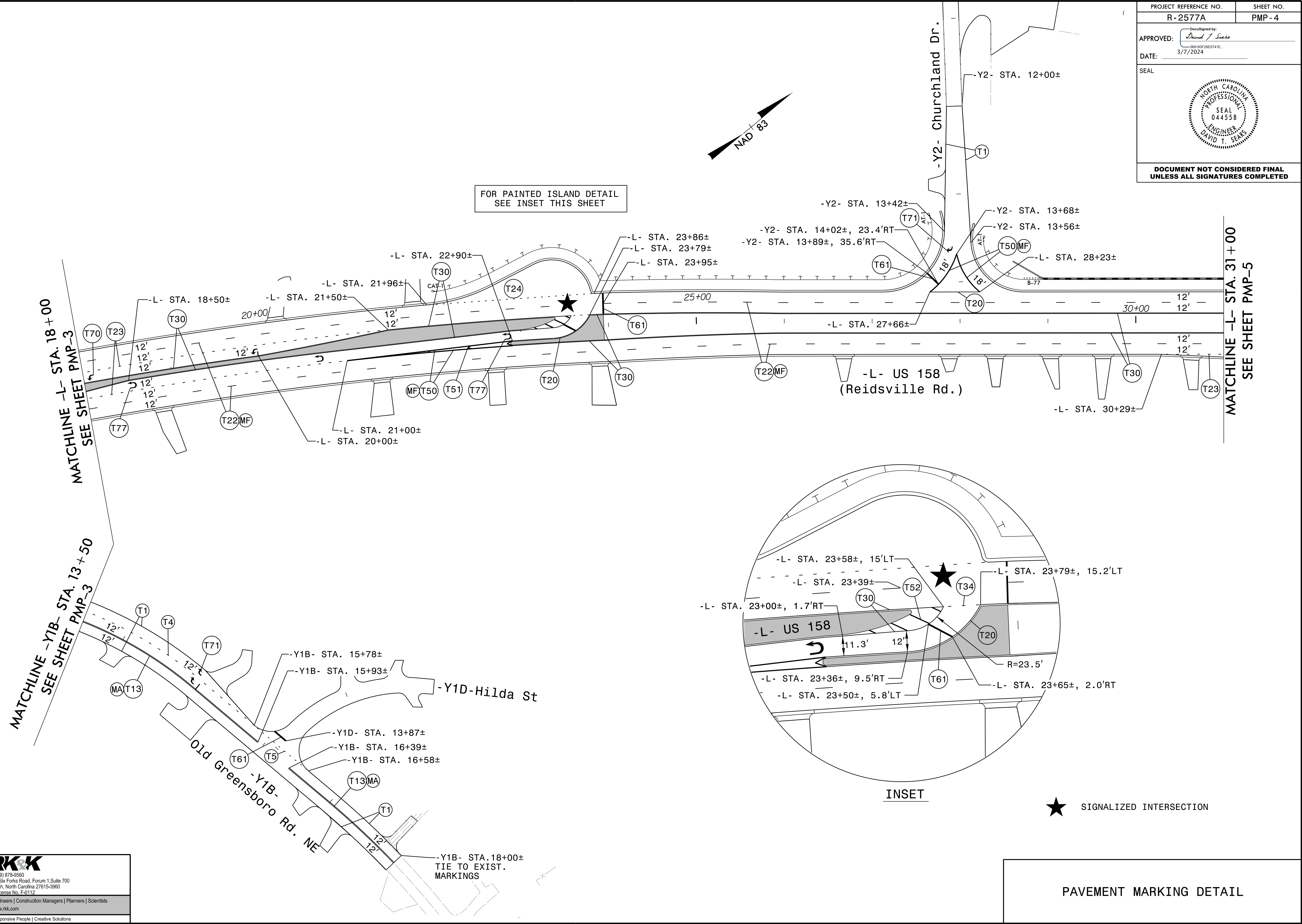

RKK
P: (919) 878-9550
6601 Six Forks Road, Forum 1, Suite 700
Raleigh, North Carolina 27615-3960
NC License No. F-0112
www.rkk.com
Engineers | Construction Managers | Planners | Scientists
Responsive People | Creative Solutions

PAVEMENT MARKING DETAIL

PROJECT REFERENCE NO. R-2577A	SHEET NO. PMP-5
APPROVED: <i>David T. Sears</i> 069183F28E5741E 3/7/2024	
DATE: 3/7/2024	
SEAL	
	
DOCUMENT NOT CONSIDERED FINAL UNLESS ALL SIGNATURES COMPLETED	

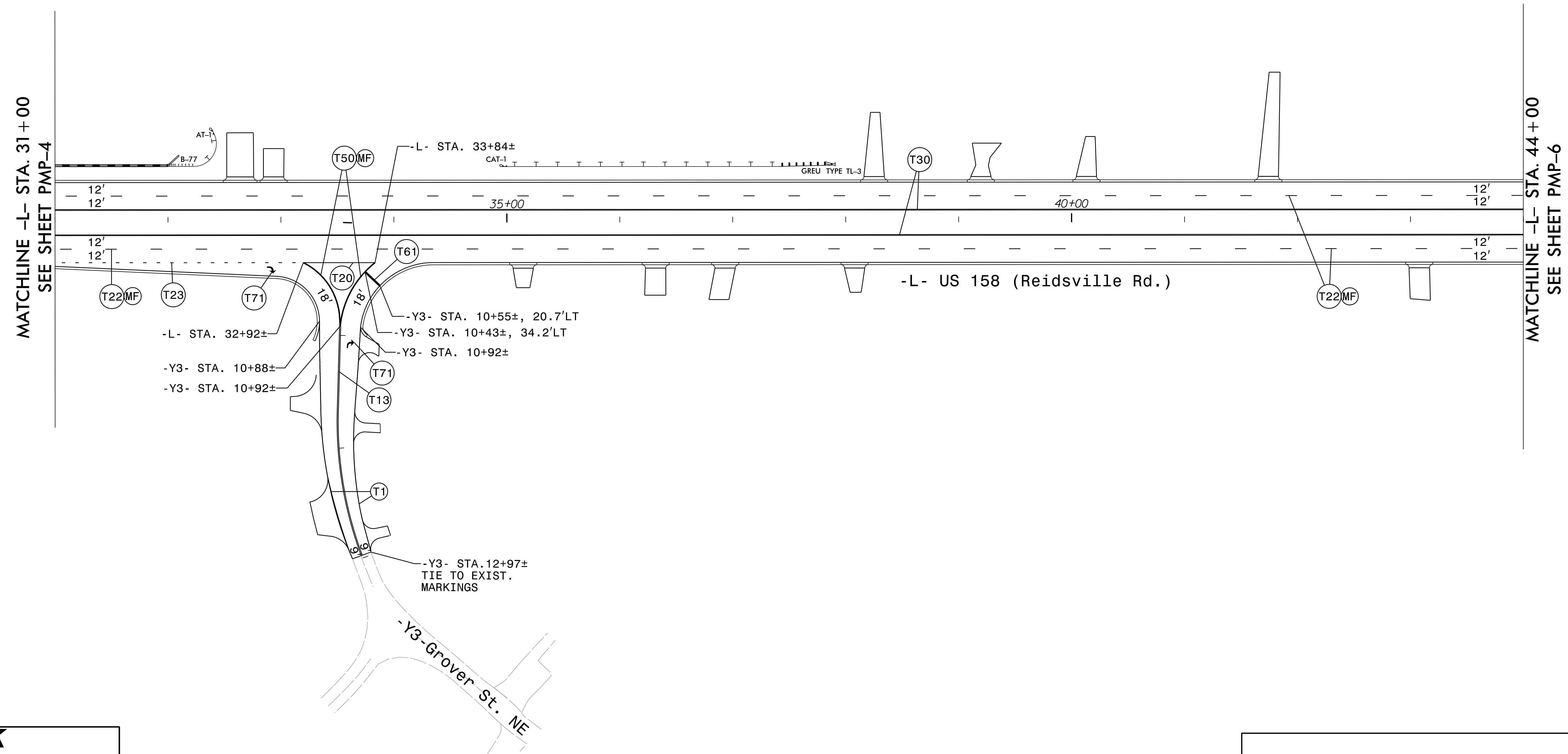
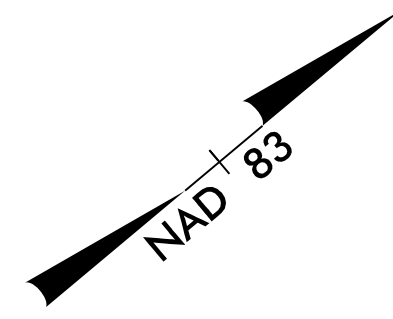

RKK
 P: (919) 878-9550
 6601 Six Forks Road, Forum 1, Suite 700
 Raleigh, North Carolina 27615-3960
 NC License No. F-0112
 Engineers | Construction Managers | Planners | Scientists
 www.rkk.com
 Responsive People | Creative Solutions

PAVEMENT MARKING DETAIL



**DOCUMENT NOT CONSIDERED FINAL
 UNLESS ALL SIGNATURES COMPLETED**

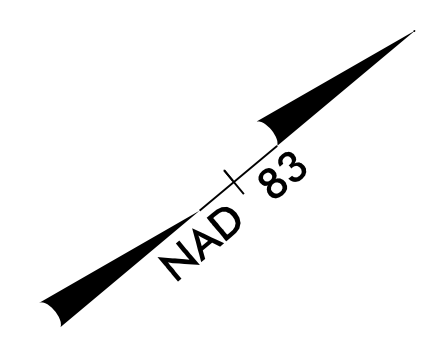

MATCHLINE -L- STA. 44 + 00 SEE SHEET PMP-5

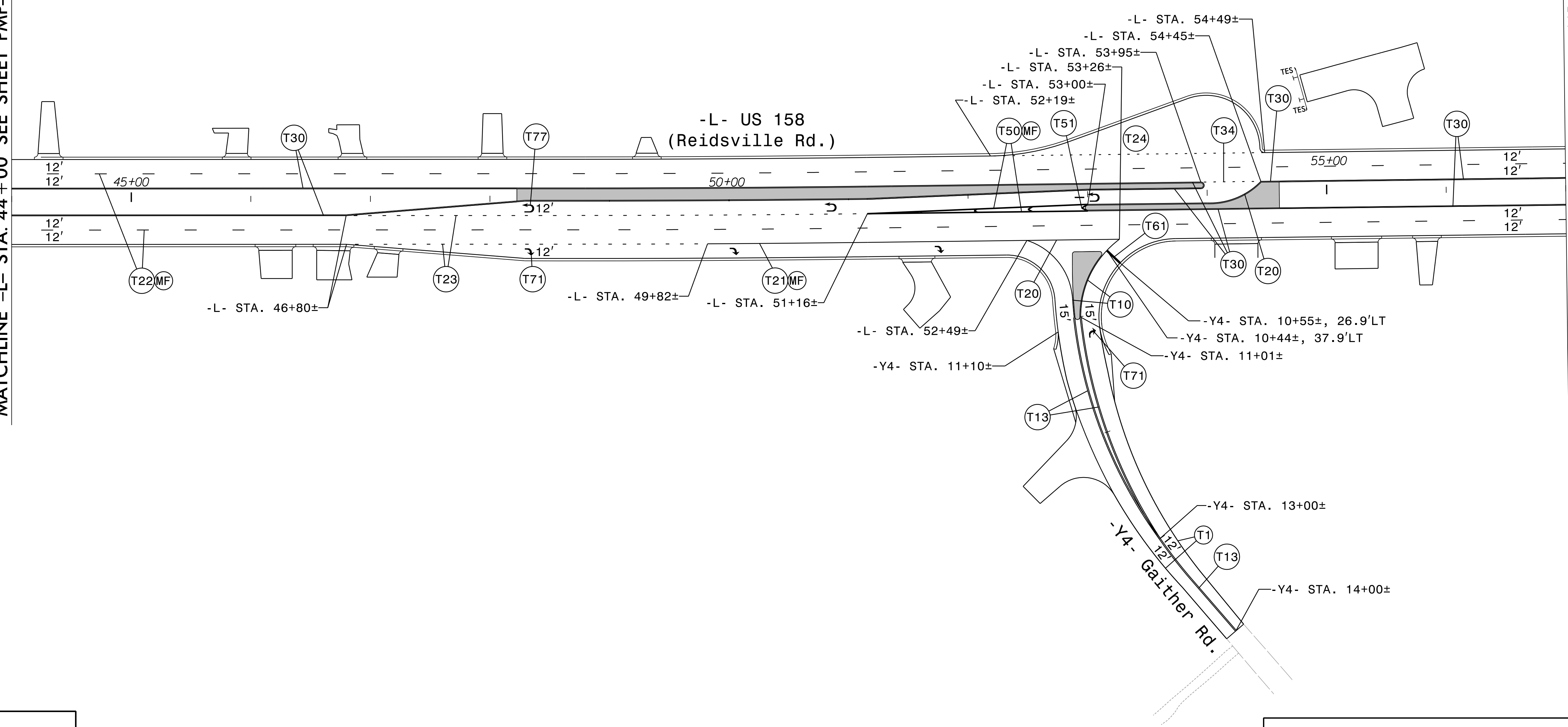

MATCHLINE -L- STA. 57 + 00 SEE SHEET PMP-7

RKK
 P: (919) 878-9550
 6601 Six Forks Road, Forum 1, Suite 700
 Raleigh, North Carolina 27615-3960
 NC License No. F-0112

Engineers | Construction Managers | Planners | Scientists
www.rkk.com

Responsive People | Creative Solutions

PAVEMENT MARKING DETAIL

PROJECT REFERENCE NO. R-2577A	SHEET NO. PMP-7
APPROVED: <i>David T. Sears</i> 089183F28E5741E 3/7/2024	
DATE: 3/7/2024	
SEAL	
	
DOCUMENT NOT CONSIDERED FINAL UNLESS ALL SIGNATURES COMPLETED	

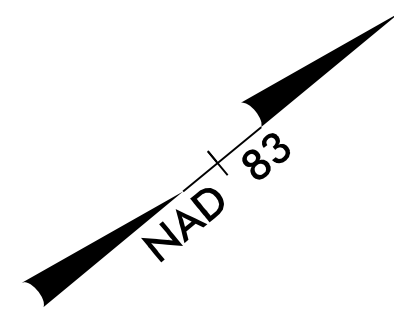

MATCHLINE -L- STA. 57+00 SEE SHEET PMP-6

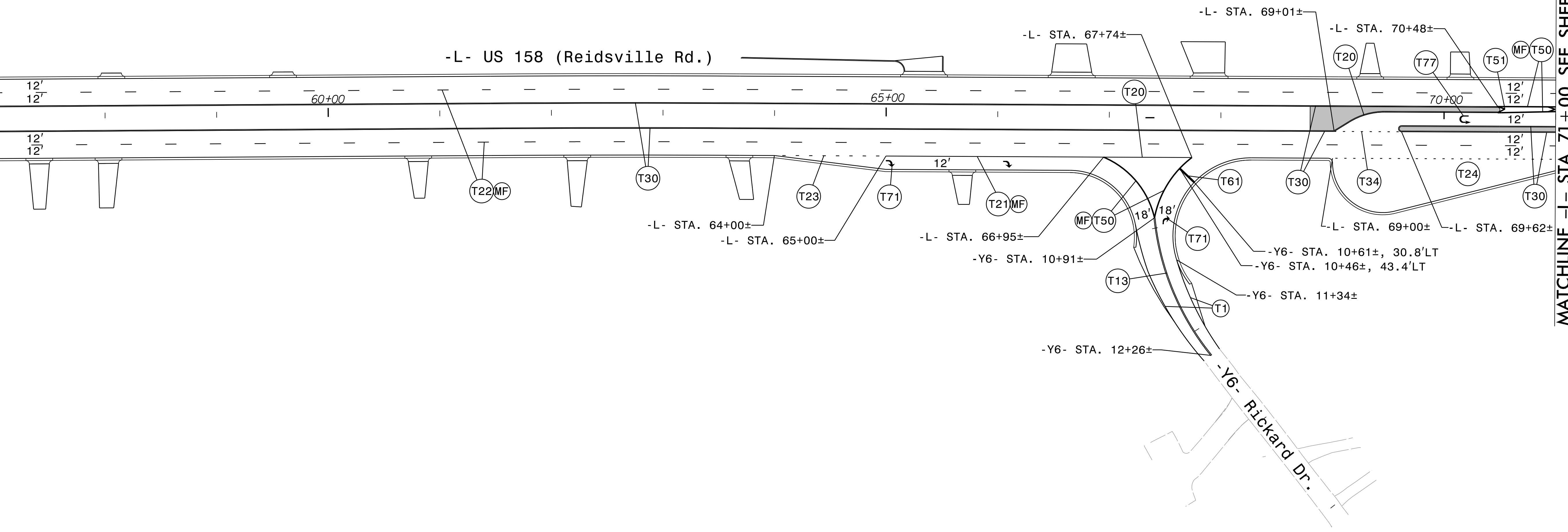

MATCHLINE -L- STA. 71+00 SEE SHEET PMP-8

RKK
 P: (919) 878-9550
 6601 Six Forks Road, Forum 1, Suite 700
 Raleigh, North Carolina 27615-3960
 NC License No. F-0112

Engineers | Construction Managers | Planners | Scientists
www.rkk.com

Responsive People | Creative Solutions

PAVEMENT MARKING DETAIL

PROJECT REFERENCE NO. R-2577A	SHEET NO. PMP-8
APPROVED: <i>David T. Sears</i> 069183F28E5741E 3/7/2024	
DATE: 3/7/2024	
SEAL	
	
DOCUMENT NOT CONSIDERED FINAL UNLESS ALL SIGNATURES COMPLETED	

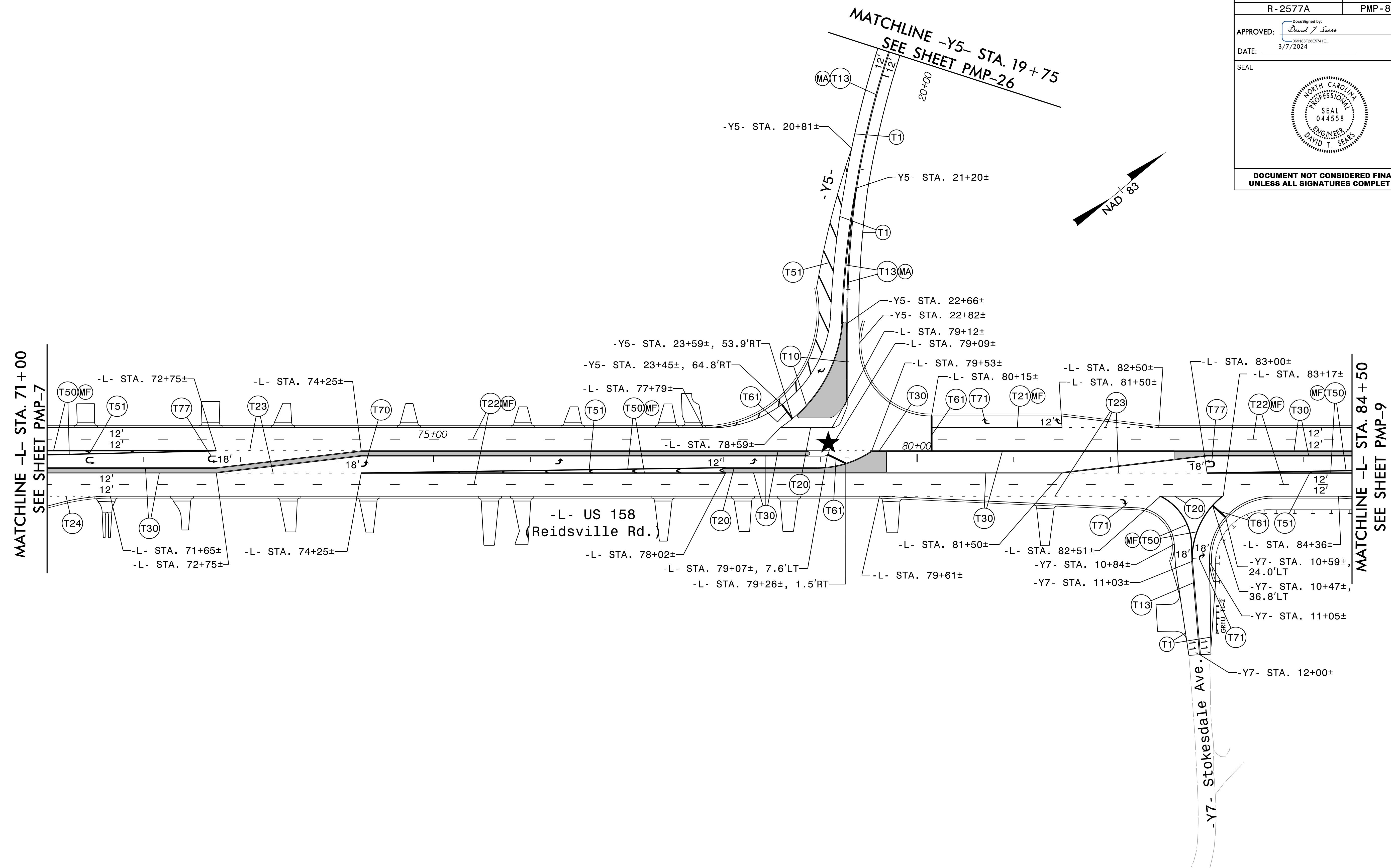

RKK
P: (919) 878-9550
6601 Six Forks Road, Forum 1, Suite 700
Raleigh, North Carolina 27615-3960
NC License No. F-0112

Engineers | Construction Managers | Planners | Scientists
www.rkk.com

Responsive People | Creative Solutions

PAVEMENT MARKING DETAIL

PROJECT REFERENCE NO. R-2577A	SHEET NO. PMP-9
APPROVED: <i>David T. Sears</i> 089183F28E5741E 3/7/2024	
DATE: 3/7/2024	
SEAL	
	
DOCUMENT NOT CONSIDERED FINAL UNLESS ALL SIGNATURES COMPLETED	

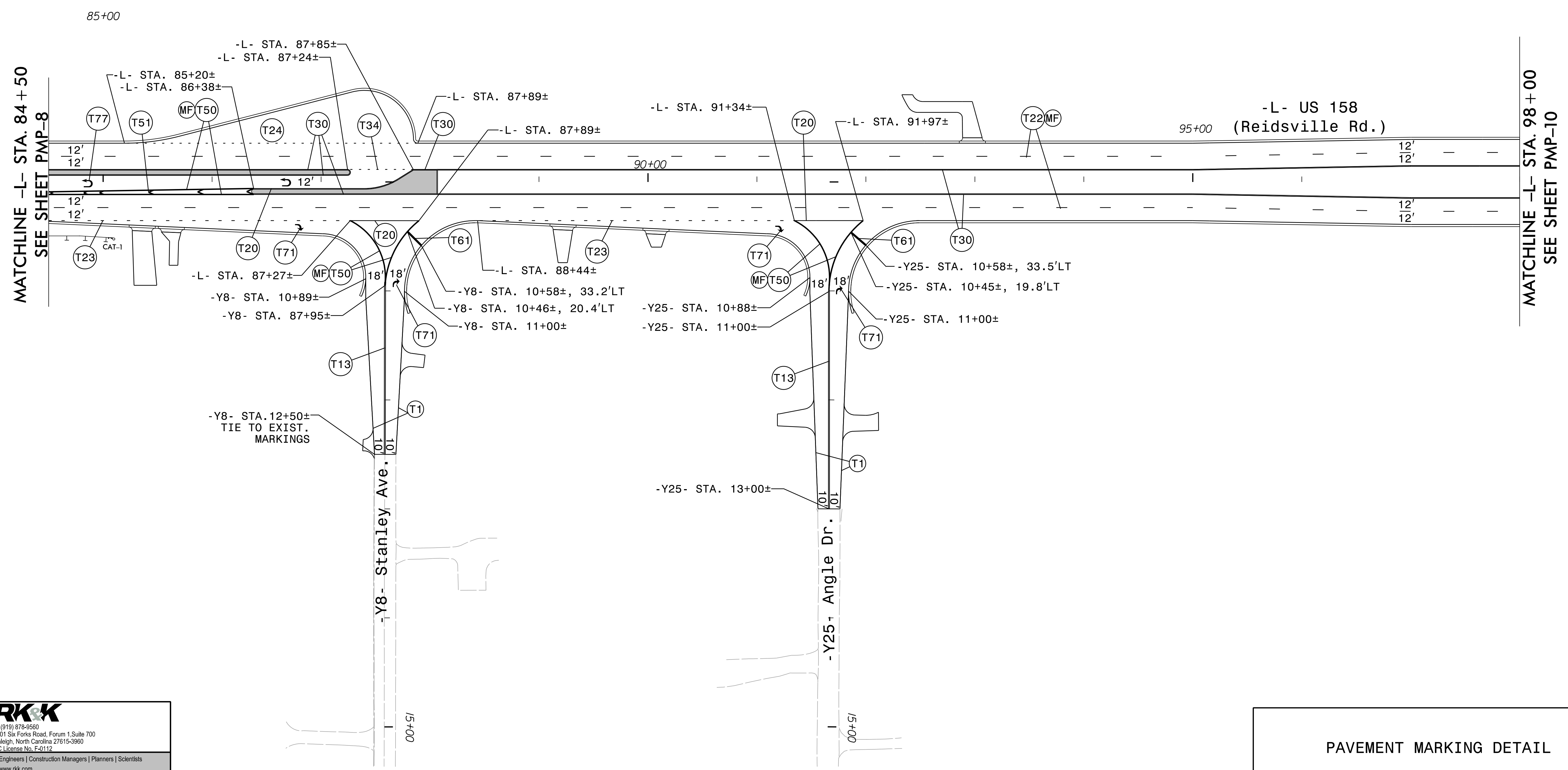

RKK
 P: (919) 878-9550
 8601 Six Forks Road, Forum 1, Suite 700
 Raleigh, North Carolina 27615-3960
 NC License No. F-0112
 Engineers | Construction Managers | Planners | Scientists
 www.rkk.com
 Responsive People | Creative Solutions

PAVEMENT MARKING DETAIL

PROJECT REFERENCE NO. R-2577A	SHEET NO. PMP-10
APPROVED: <i>David T. Sears</i> 089183F28E5741E 3/7/2024	
DATE: 3/7/2024	
SEAL	
	
DOCUMENT NOT CONSIDERED FINAL UNLESS ALL SIGNATURES COMPLETED	

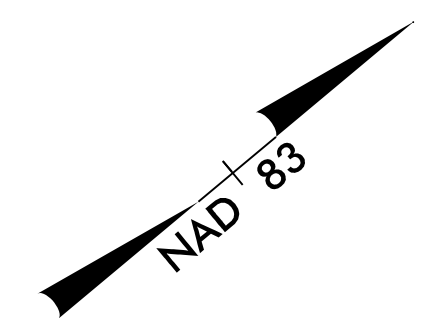
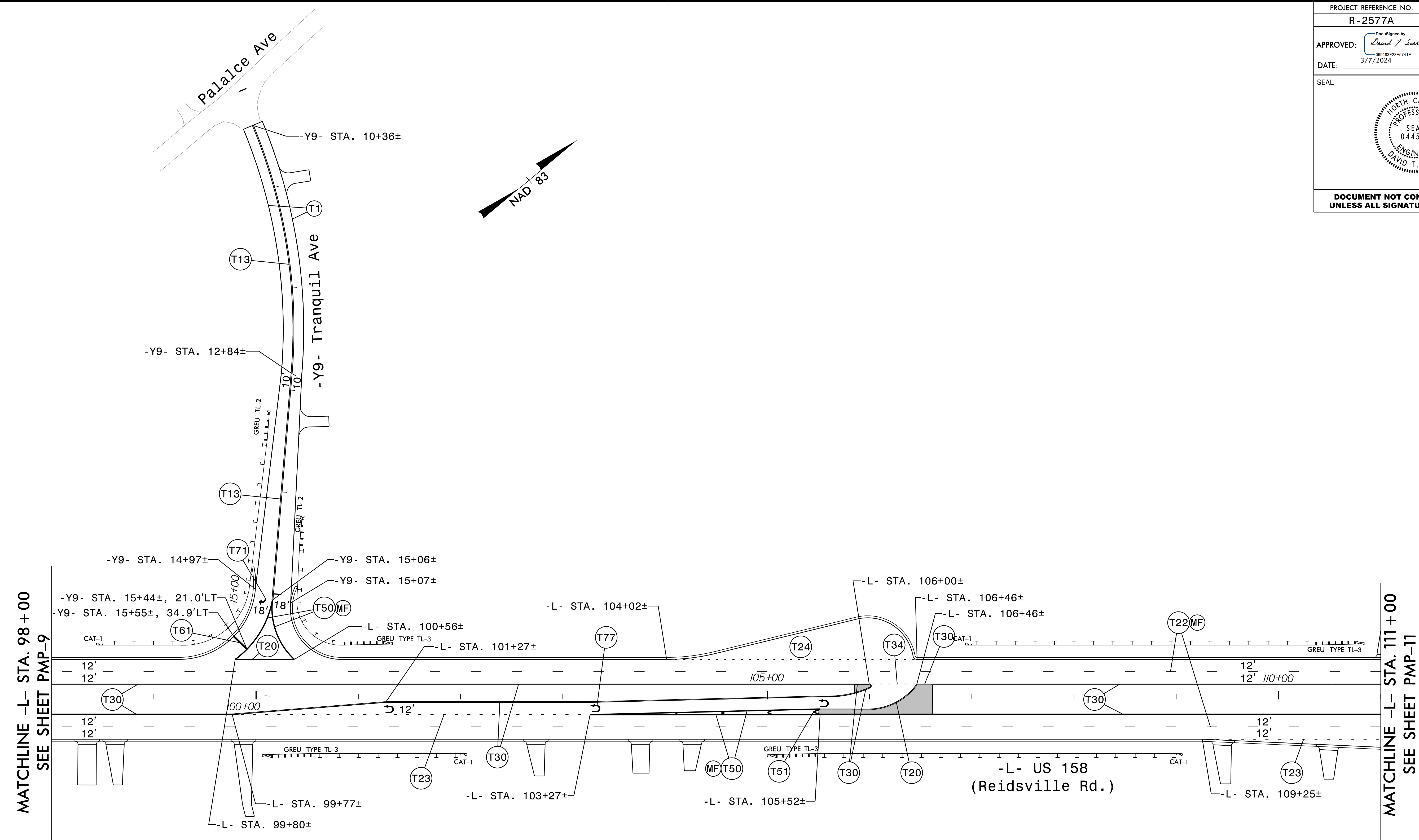

MATCHLINE -L- STA. 98+00
SEE SHEET PMP-9

MATCHLINE -L- STA. 111+00
SEE SHEET PMP-11

-L- US 158
(Reidsville Rd.)

RKK
 P: (919) 878-9550
 6601 Six Forks Road, Forum 1, Suite 700
 Raleigh, North Carolina 27615-3960
 NC License No. F-0112
 Engineers | Construction Managers | Planners | Scientists
 www.rkk.com
 Responsive People | Creative Solutions

PAVEMENT MARKING DETAIL

PROJECT REFERENCE NO. R-2577A	SHEET NO. PMP-11
APPROVED: <i>David T. Sears</i> 069183F28E5741E 3/7/2024	
DATE: 3/7/2024	
SEAL	
	
DOCUMENT NOT CONSIDERED FINAL UNLESS ALL SIGNATURES COMPLETED	

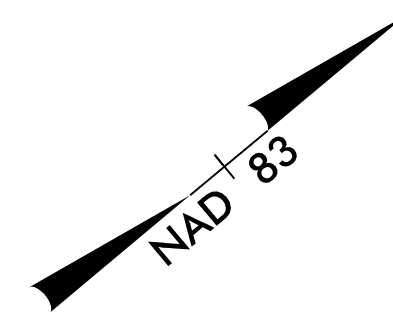
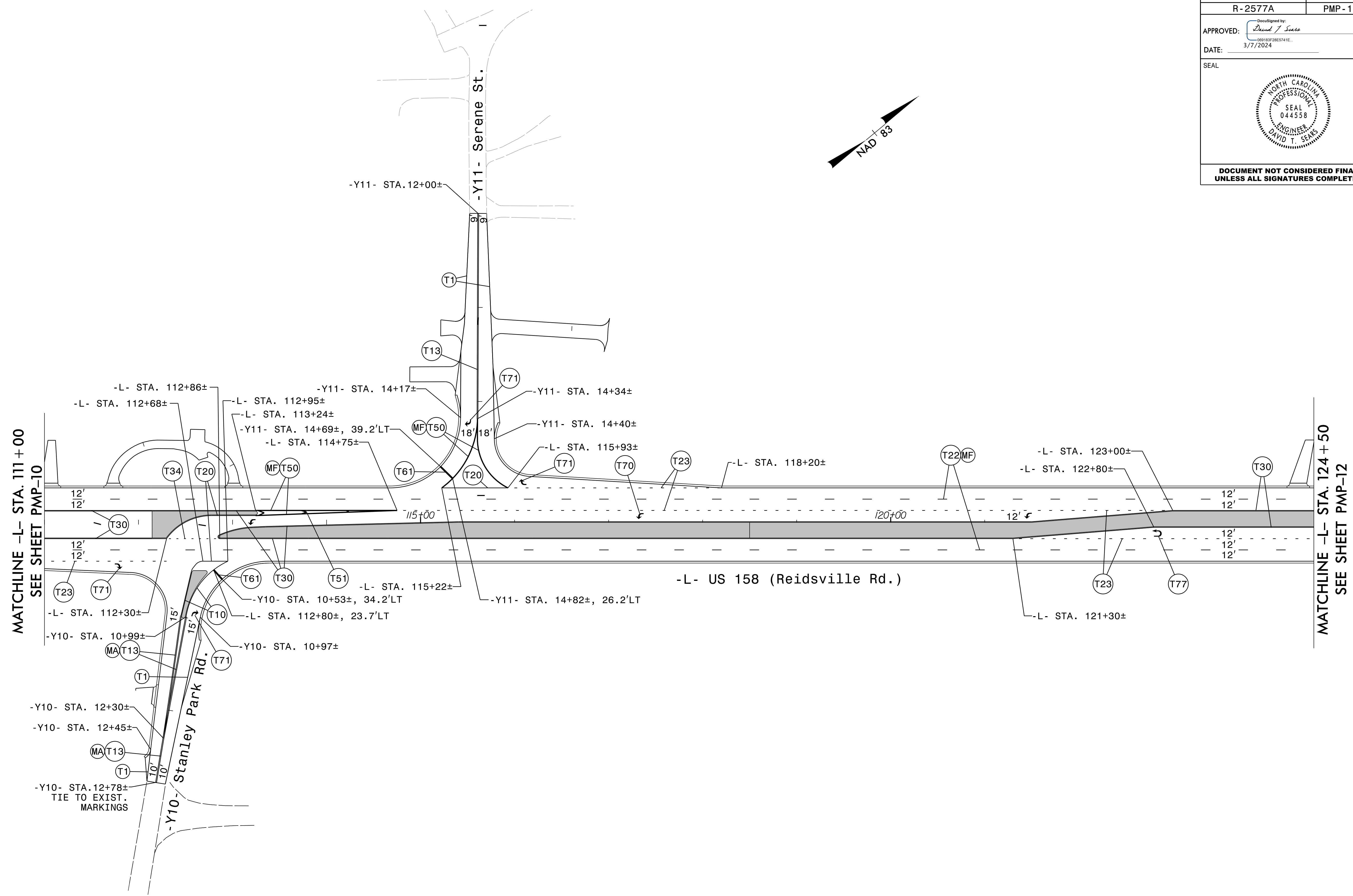

RKK
 P: (919) 878-9550
 6601 Six Forks Road, Forum 1, Suite 700
 Raleigh, North Carolina 27615-3960
 NC License No. F-0112

Engineers | Construction Managers | Planners | Scientists
 www.rkk.com

Responsive People | Creative Solutions

PAVEMENT MARKING DETAIL

PROJECT REFERENCE NO. R-2577A	SHEET NO. PMP-12
APPROVED: <i>David T. Sears</i> 089183F28E5741E DATE: 3/7/2024	
SEAL	
	
DOCUMENT NOT CONSIDERED FINAL UNLESS ALL SIGNATURES COMPLETED	

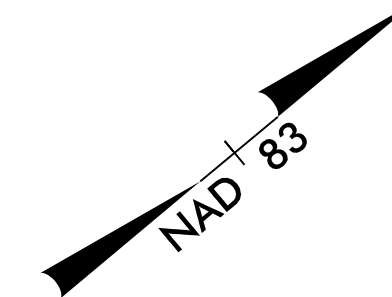

MATCHLINE -L- STA. 124 + 50 SEE SHEET PMP-11

MATCHLINE -L- STA. 138 + 50 SEE SHEET PMP-13

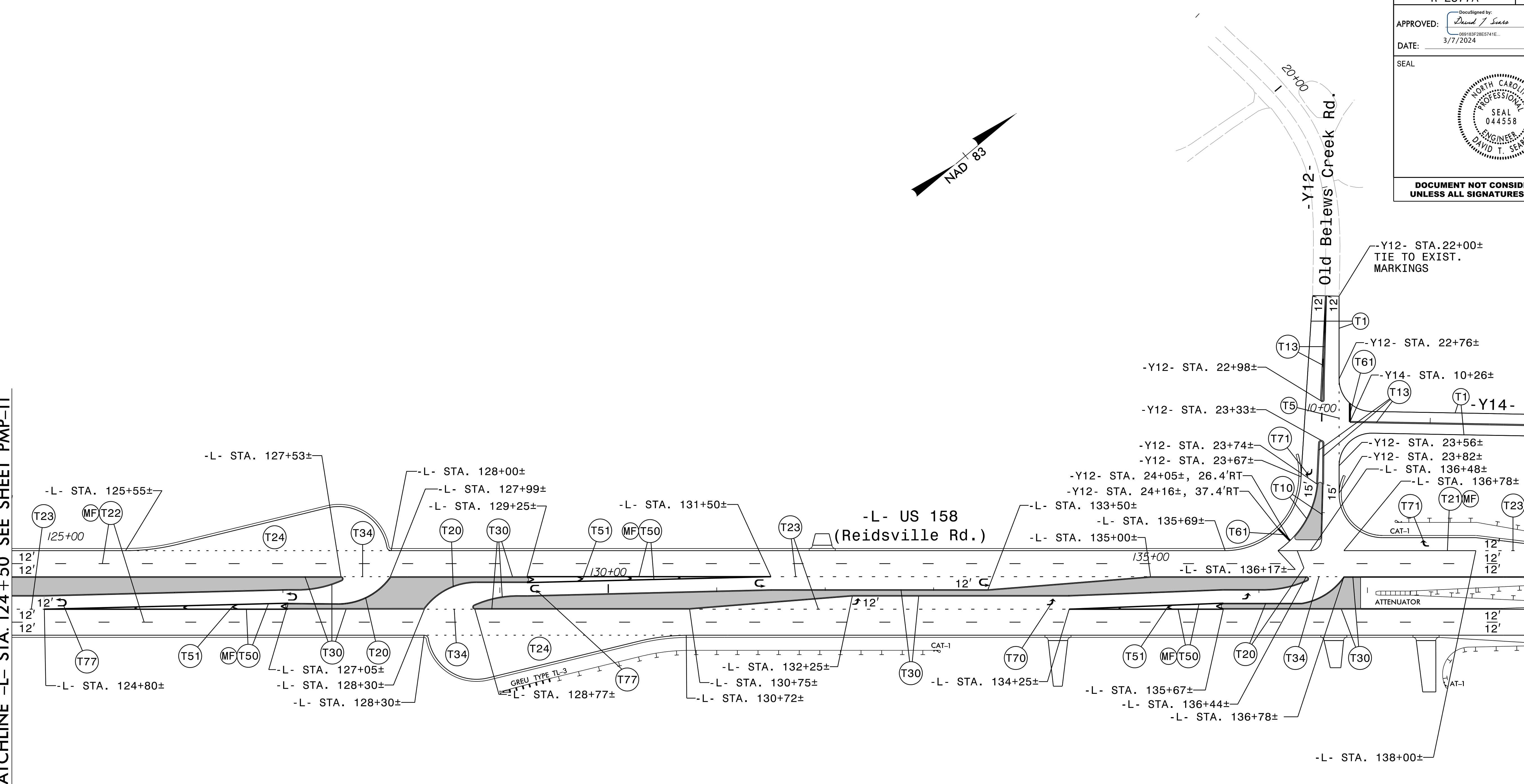

RKK
P: (919) 878-9550
6601 Six Forks Road, Forum 1, Suite 700
Raleigh, North Carolina 27615-3960
NC License No. F-0112
Engineers | Construction Managers | Planners | Scientists
www.rkk.com
Responsive People | Creative Solutions

PAVEMENT MARKING DETAIL

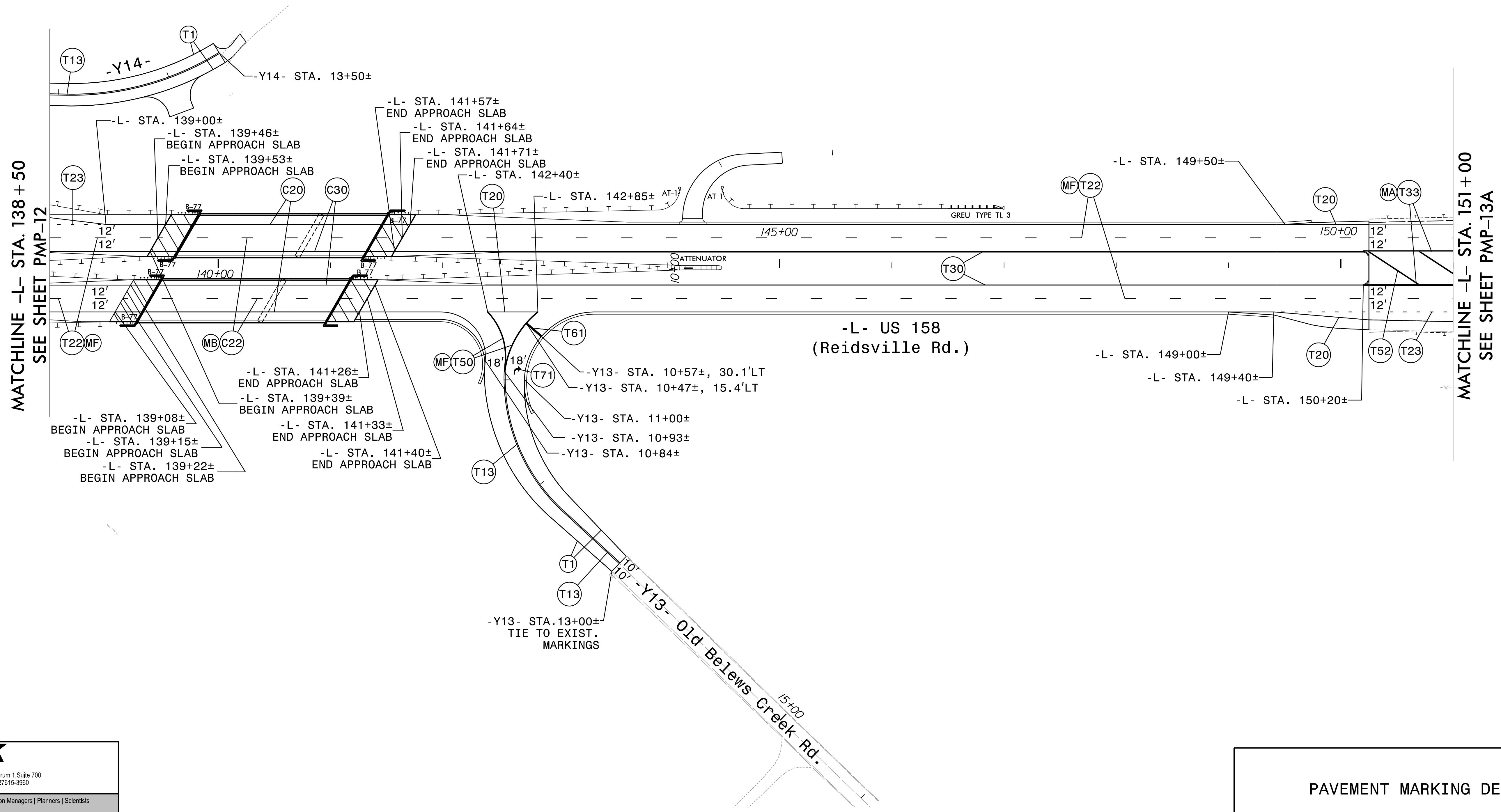
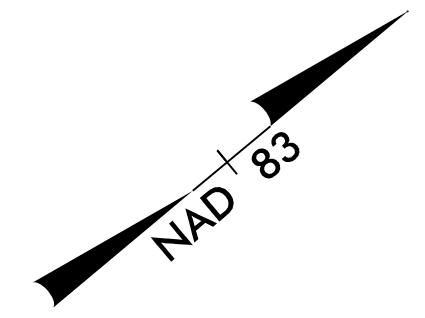

R:\2024\2577A_PMP-13.dgn

PROJECT REFERENCE NO. R-2577A	SHEET NO. PMP-13A
APPROVED: <i>David T. Sears</i> 089183F28E5741E 3/7/2024	
DATE: 3/7/2024	
SEAL	
	
DOCUMENT NOT CONSIDERED FINAL UNLESS ALL SIGNATURES COMPLETED	

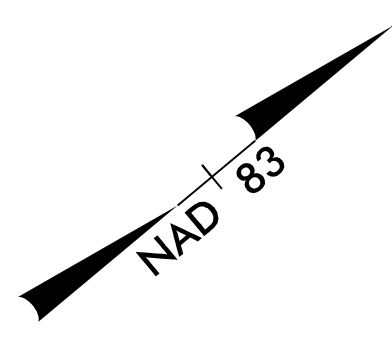

MATCHLINE -L- STA. 151+00
SEE SHEET PMP-13

MATCHLINE -L- STA. 164+00
SEE SHEET PMP-14

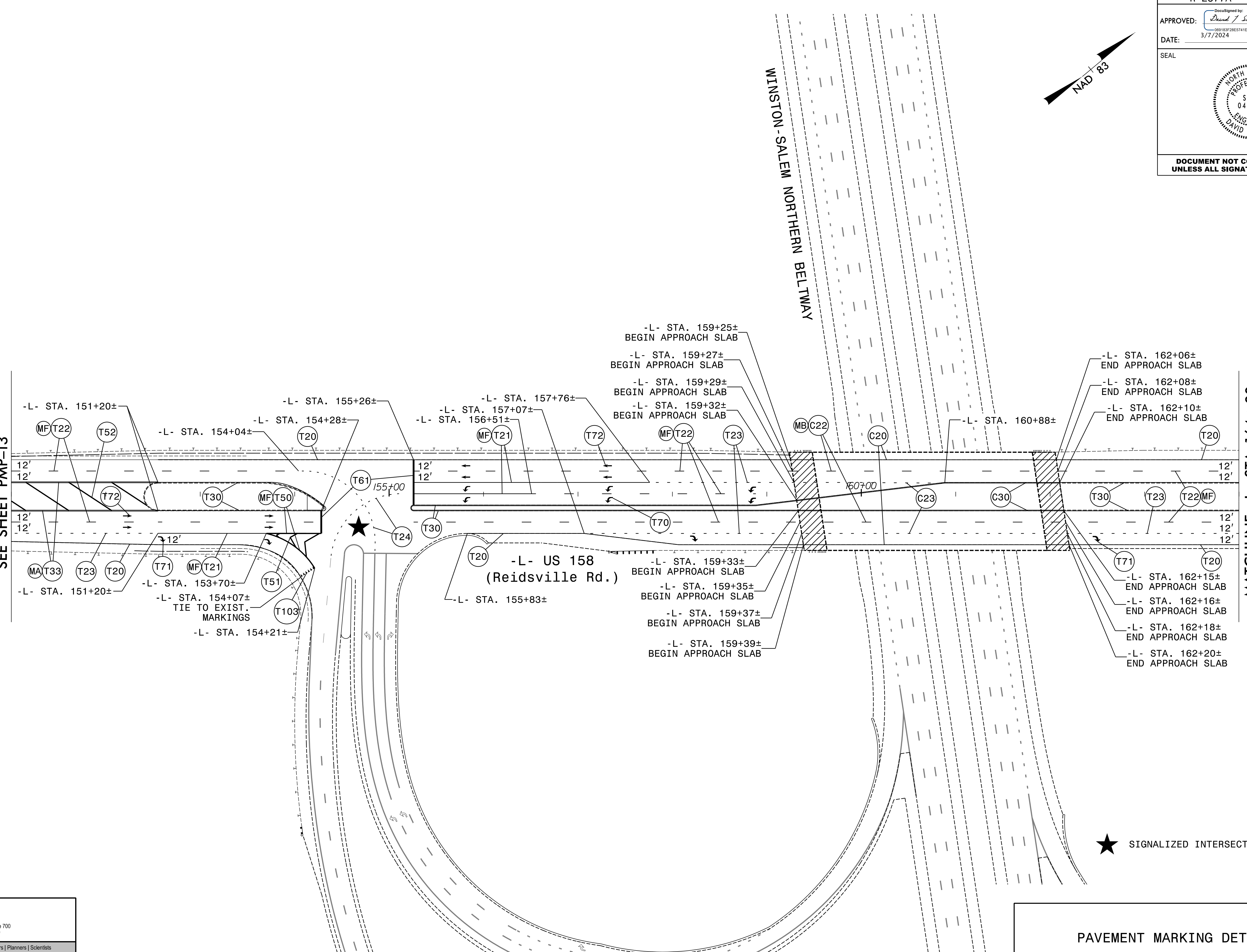

★ SIGNALIZED INTERSECTION

PAVEMENT MARKING DETAIL

RK&K
 P: (919) 878-9550
 8601 Six Forks Road, Forum 1, Suite 700
 Raleigh, North Carolina 27615-3960
 NC License No. F-0112
 Engineers | Construction Managers | Planners | Scientists
 www.rkk.com
 Responsive People | Creative Solutions

R:\2024\2577A_PMP-13A.dgn

PROJECT REFERENCE NO. R-2577A	SHEET NO. PMP - 14
APPROVED: <i>David T. Sears</i> 089183F28E5741E 3/7/2024	
DATE: 3/7/2024	
SEAL	
	
DOCUMENT NOT CONSIDERED FINAL UNLESS ALL SIGNATURES COMPLETED	

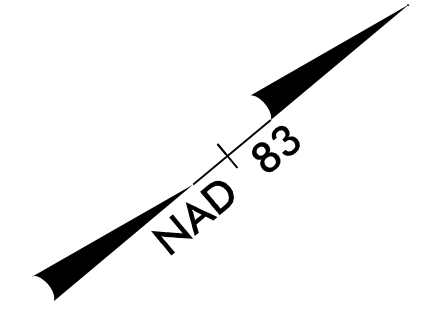

MATCHLINE -L- STA. 164 + 00
SEE SHEET PMP-13A

MATCHLINE -L- STA. 177 + 00
SEE SHEET PMP-15

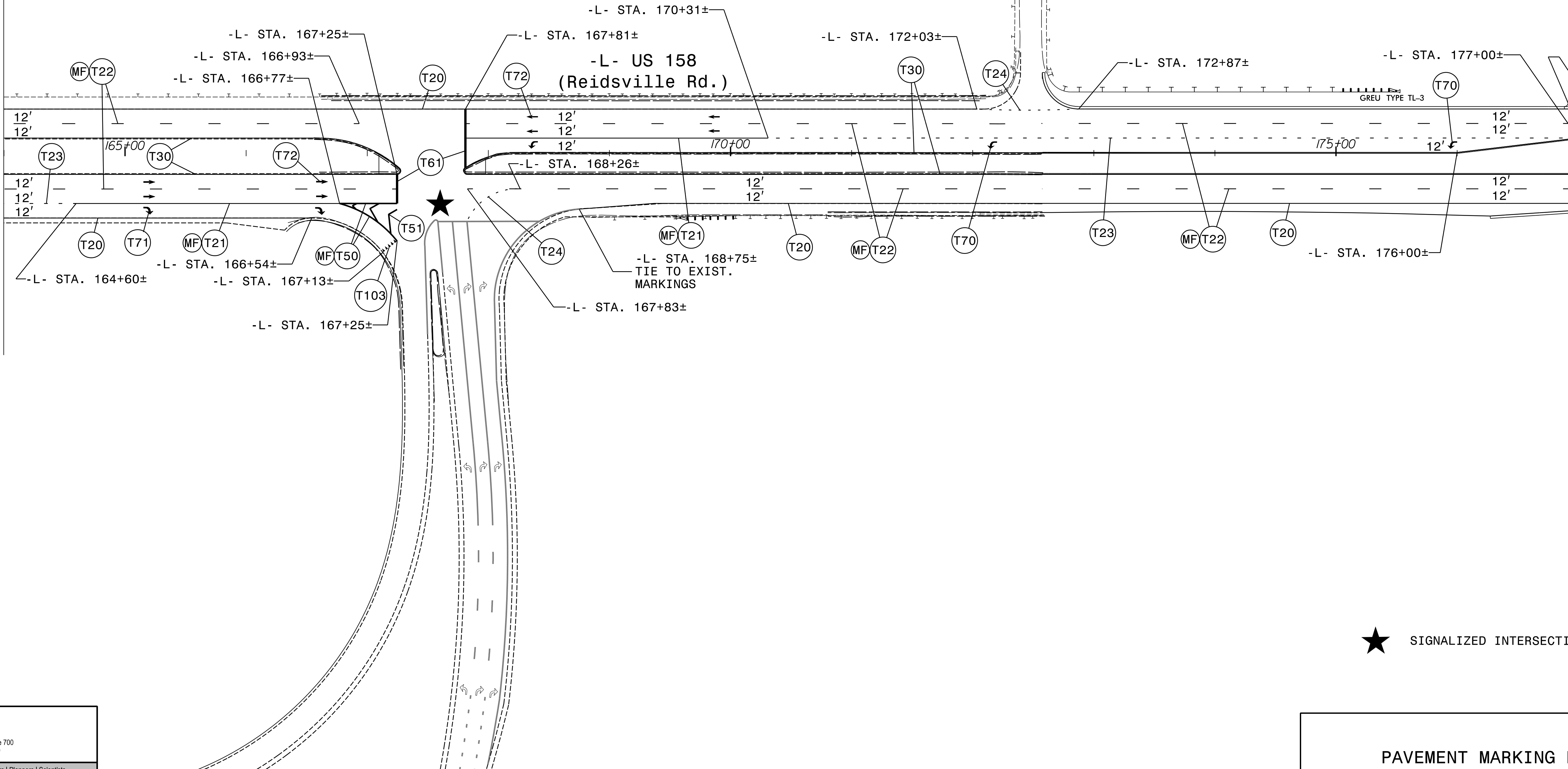

★ SIGNALIZED INTERSECTION

PAVEMENT MARKING DETAIL

RK&K
 P: (919) 878-9550
 8601 Six Forks Road, Forum 1, Suite 700
 Raleigh, North Carolina 27615-3960
 NC License No. F-0112
 Engineers | Construction Managers | Planners | Scientists
 www.rkk.com
 Responsive People | Creative Solutions

R:\2024\14_PMP-14.dgn
3/7/2024 10:41 AM
D:\2024\14_PMP-14.dgn

PROJECT REFERENCE NO. R-2577A	SHEET NO. PMP - 15
APPROVED: <i>David T. Sears</i> 089183F28E5741E DATE: 3/7/2024	
SEAL 	
DOCUMENT NOT CONSIDERED FINAL UNLESS ALL SIGNATURES COMPLETED	

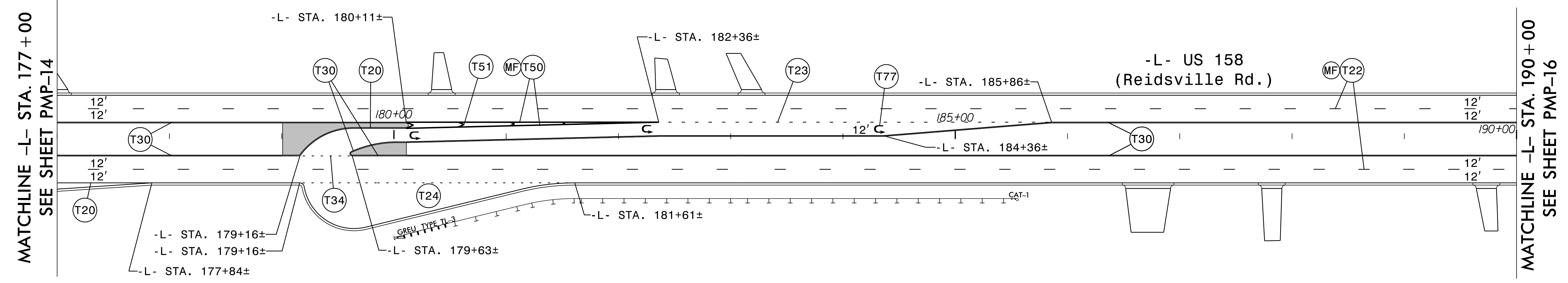
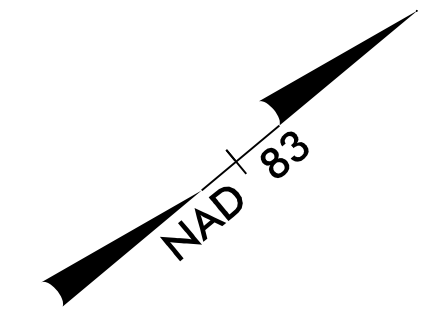

R:\2024\2577A_PMP - 15.dgn

RKK
P: (919) 878-9550
6601 Six Forks Road, Forum 1, Suite 700
Raleigh, North Carolina 27615-3960
NC License No. F-0112

Engineers | Construction Managers | Planners | Scientists
www.rkk.com

Responsive People | Creative Solutions

PAVEMENT MARKING DETAIL

PROJECT REFERENCE NO. R-2577A	SHEET NO. PMP-16
APPROVED: <i>David T. Sears</i> 089183F28E5741E 3/7/2024	
DATE: 3/7/2024	
SEAL	
	
DOCUMENT NOT CONSIDERED FINAL UNLESS ALL SIGNATURES COMPLETED	

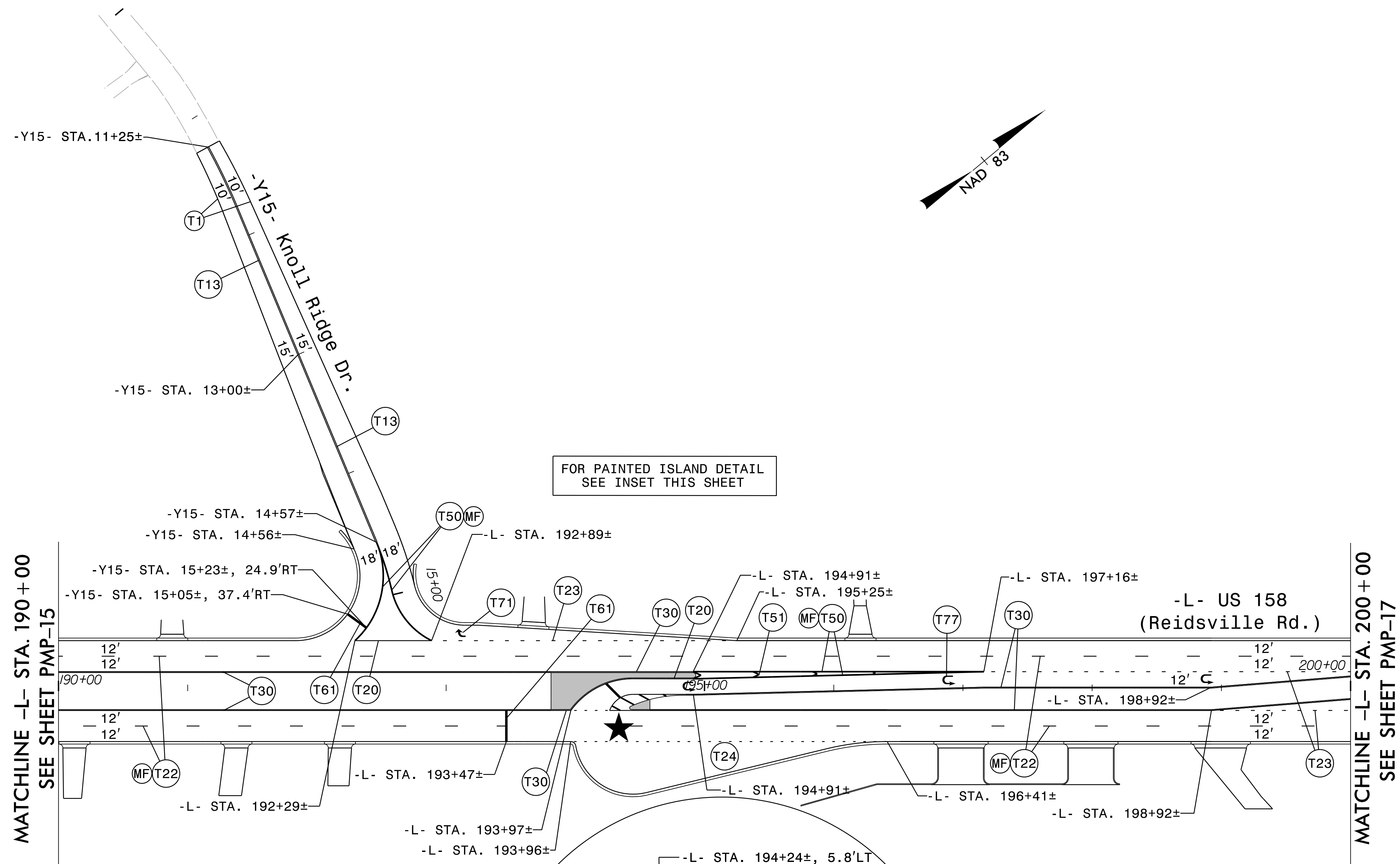

FOR PAINTED ISLAND DETAIL
SEE INSET THIS SHEET

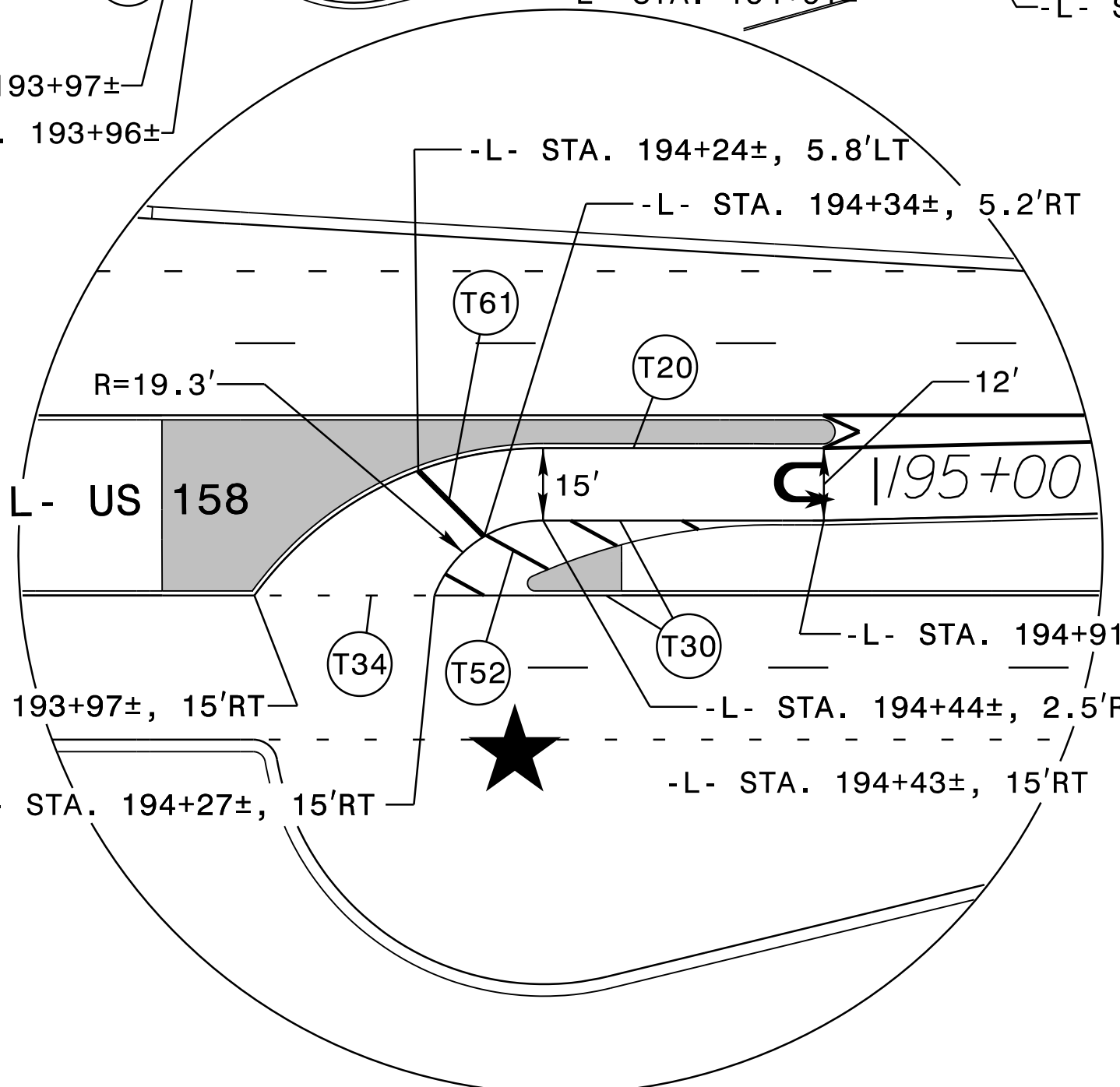

INSET

★ SIGNALIZED INTERSECTION

PAVEMENT MARKING DETAIL

RK&K
 P: (919) 878-9550
 6601 Six Forks Road, Forum 1, Suite 700
 Raleigh, North Carolina 27615-3960
 NC License No. F-0112
 Engineers | Construction Managers | Planners | Scientists
 www.rkk.com
 Responsive People | Creative Solutions

R:\2024\2577A_PMP - 16.dgn

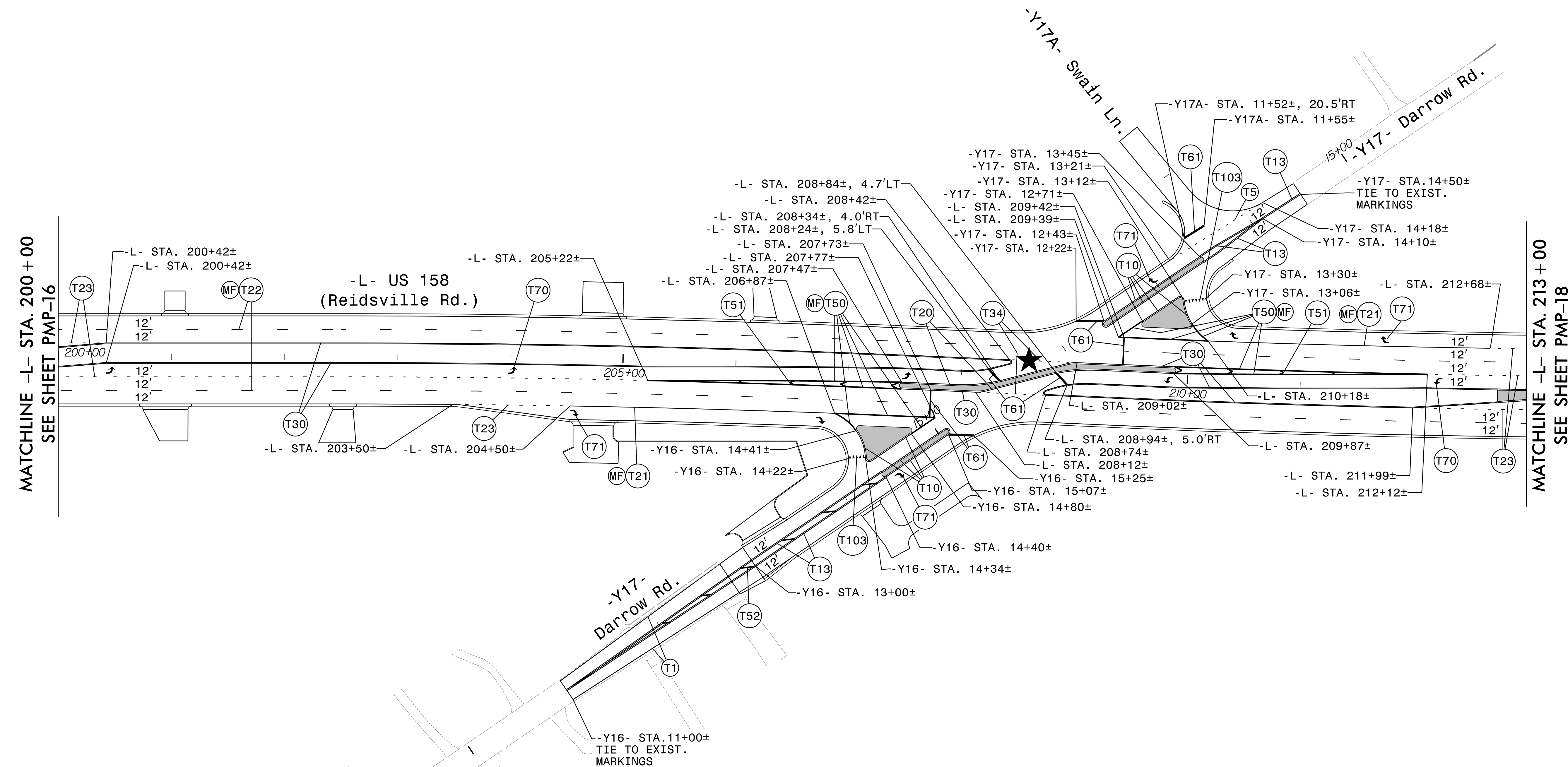
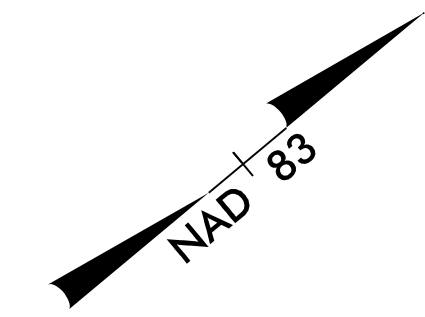

★ SIGNALIZED INTERSECTION

PAVEMENT MARKING DETAIL

PROJECT REFERENCE NO. R-2577A	SHEET NO. PMP-18
APPROVED: <i>David T. Sears</i> 089183F28E5741E..	
DATE: 3/7/2024	
SEAL	
	
DOCUMENT NOT CONSIDERED FINAL UNLESS ALL SIGNATURES COMPLETED	

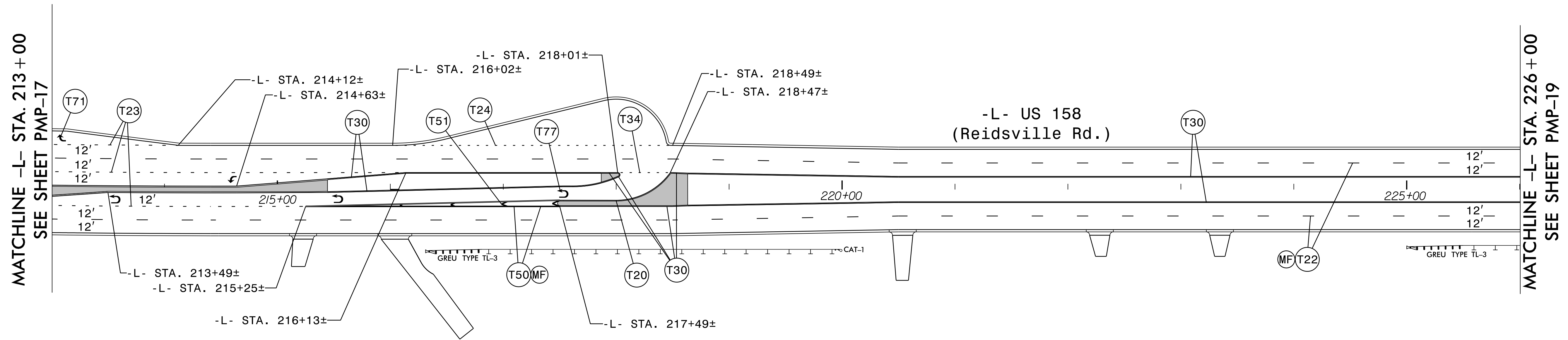
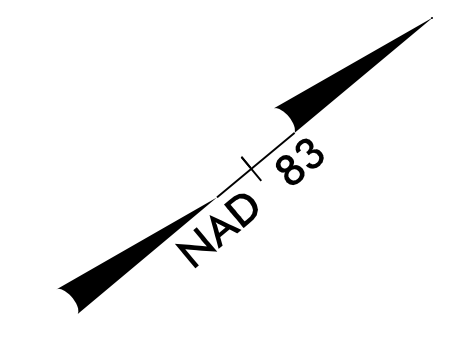

R:\2024\2577A_PMP-18.dgn

RKK
 P: (919) 878-9550
 6601 Six Forks Road, Forum 1, Suite 700
 Raleigh, North Carolina 27615-3960
 NC License No. F-0112

Engineers | Construction Managers | Planners | Scientists
www.rkk.com

Responsive People | Creative Solutions

PAVEMENT MARKING DETAIL

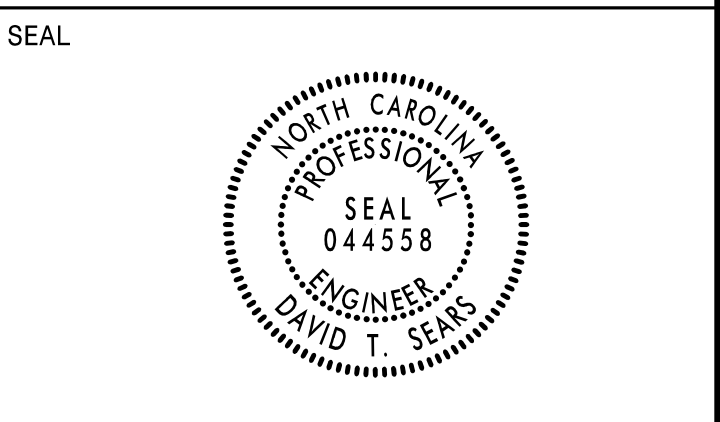

**DOCUMENT NOT CONSIDERED FINAL
 UNLESS ALL SIGNATURES COMPLETED**

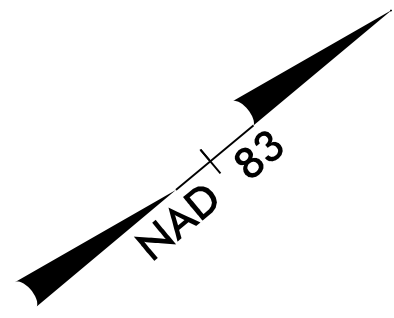

MATCHLINE -L- STA. 226 + 00
SEE SHEET PMP-18

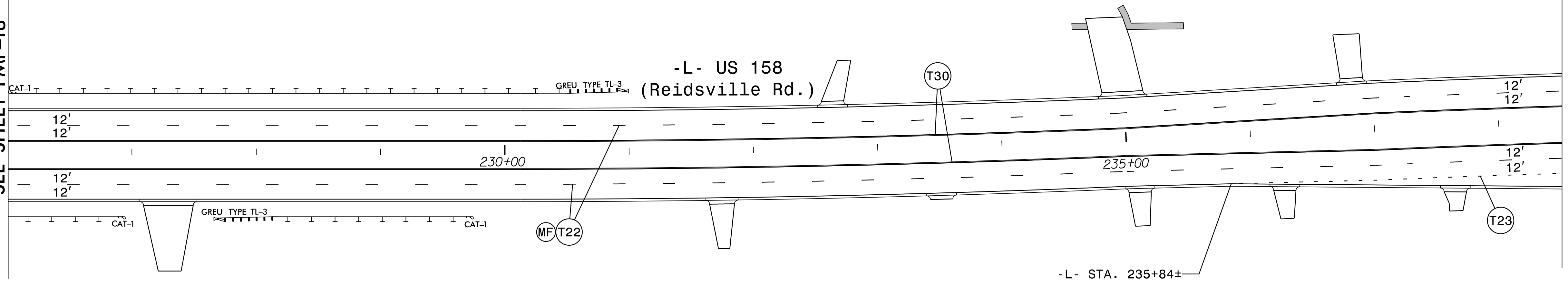

MATCHLINE -L- STA. 238 + 50
SEE SHEET PMP-20

R:\2024\2577A_PMP - 19.dgn



RKK
 P: (919) 878-9550
 6601 Six Forks Road, Forum 1, Suite 700
 Raleigh, North Carolina 27615-3960
 NC License No. F-0112

Engineers | Construction Managers | Planners | Scientists
 www.rkk.com

Responsive People | Creative Solutions

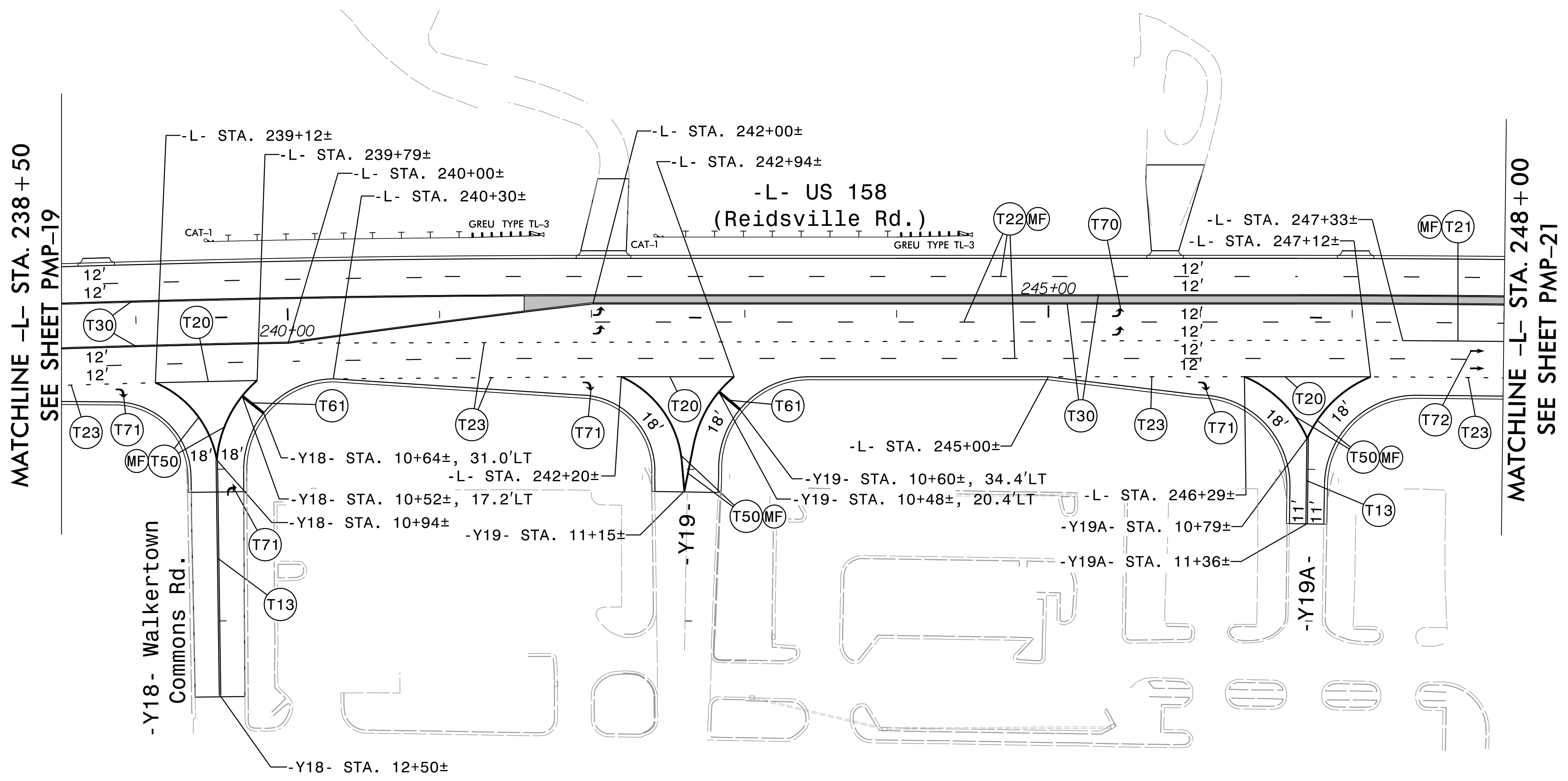
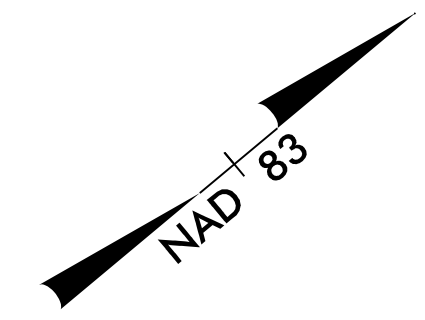
PAVEMENT MARKING DETAIL

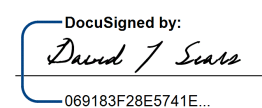

PROJECT REFERENCE NO. R-2577A	SHEET NO. PMP-21
APPROVED:  088183F28E5741E. 3/7/2024	
DATE: 3/7/2024	
SEAL 	
DOCUMENT NOT CONSIDERED FINAL UNLESS ALL SIGNATURES COMPLETED	

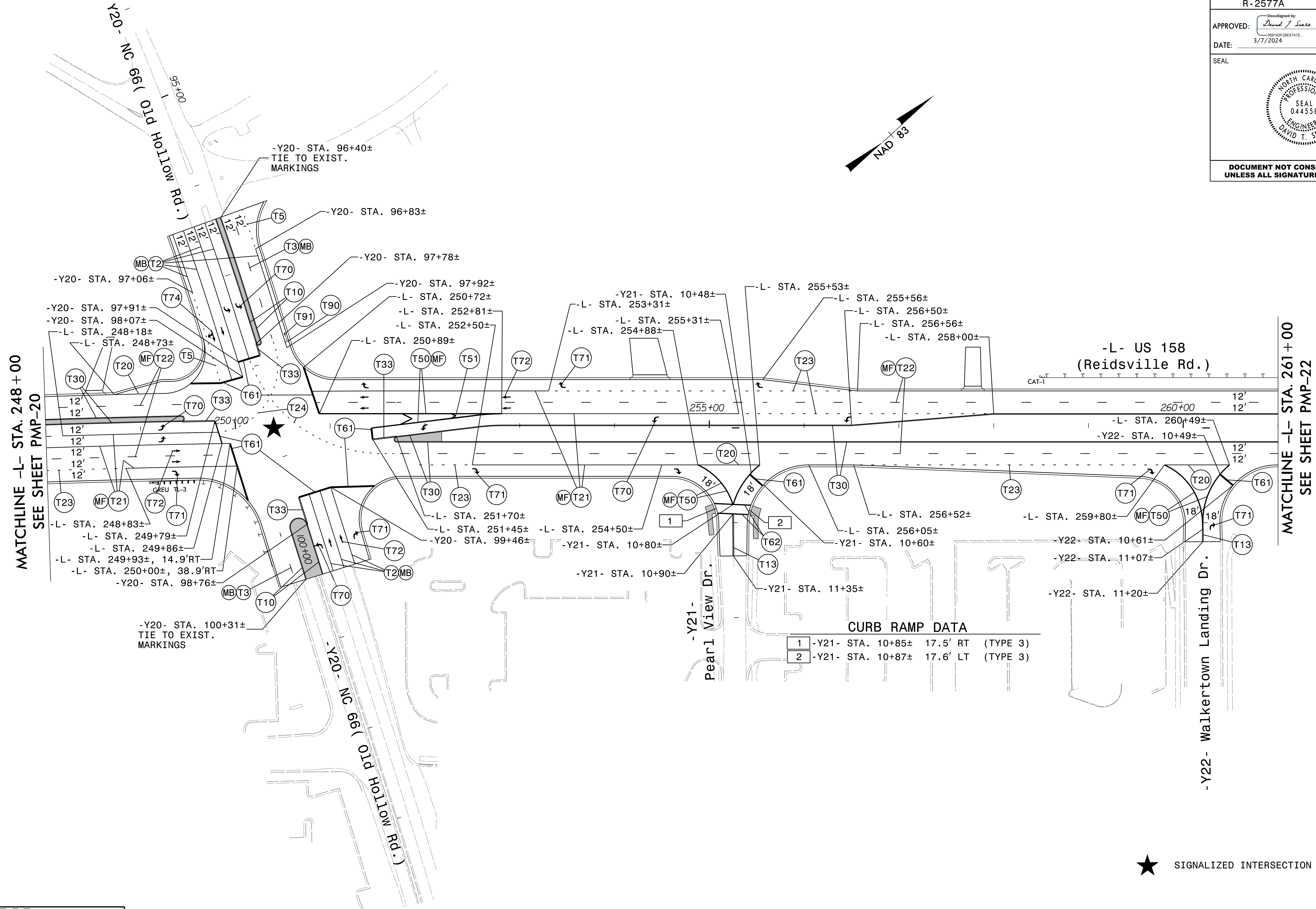

MATCHLINE -L- STA. 248+00
SEE SHEET PMP-20

MATCHLINE -L- STA. 261+00
SEE SHEET PMP-22

CURB RAMP DATA

1	-Y21- STA. 10+85±	17.5' RT	(TYPE 3)
2	-Y21- STA. 10+87±	17.6' LT	(TYPE 3)

-Y20- STA. 100+31±
TIE TO EXIST.
MARKINGS

-Y20- STA. 96+40±
TIE TO EXIST.
MARKINGS

★ SIGNALIZED INTERSECTION

PAVEMENT MARKING DETAIL

RKK
P: (919) 878-8550
6601 Six Forks Road, Forum 1, Suite 700
Raleigh, North Carolina 27615-3960
NC License No. F-0112
Engineers | Construction Managers | Planners | Scientists
www.rkk.com
Responsive People | Creative Solutions

PROJECT REFERENCE NO. R-2577A	SHEET NO. PMP-22
APPROVED: <i>David T. Sears</i> 069183F28E5741E...	
DATE: 3/7/2024	
SEAL	
	
DOCUMENT NOT CONSIDERED FINAL UNLESS ALL SIGNATURES COMPLETED	

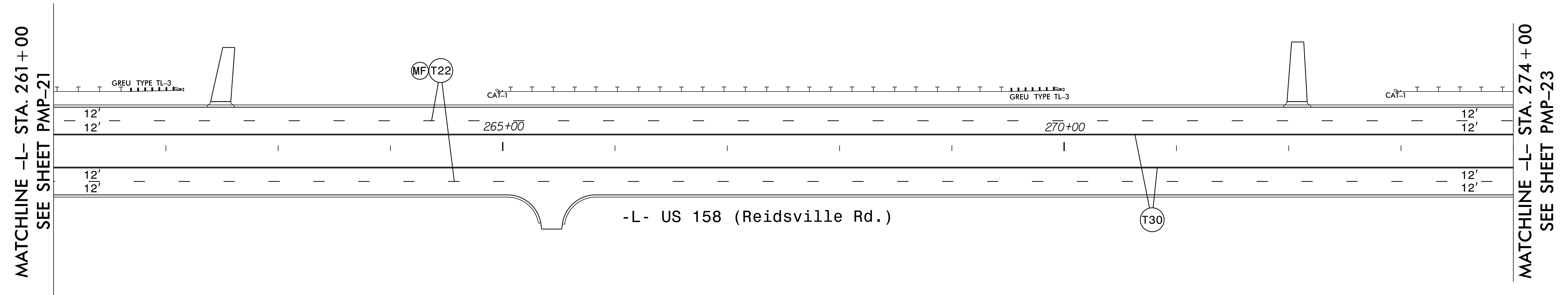
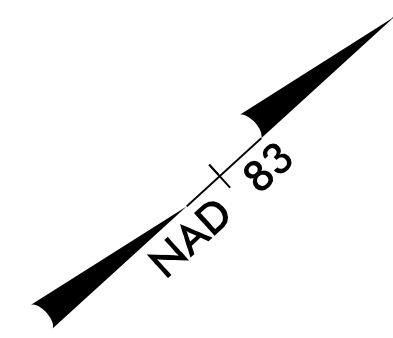

R:\2024\1_PMP-22.dgn

RKK
 P: (919) 878-9550
 6601 Six Forks Road, Forum 1, Suite 700
 Raleigh, North Carolina 27615-3960
 NC License No. F-0112

Engineers | Construction Managers | Planners | Scientists
www.rkk.com

Responsive People | Creative Solutions

PAVEMENT MARKING DETAIL

PROJECT REFERENCE NO. R-2577A	SHEET NO. PMP-23
APPROVED: <i>David T. Sears</i> 089183F28E5741E 3/7/2024	
DATE: 3/7/2024	
SEAL	
	
DOCUMENT NOT CONSIDERED FINAL UNLESS ALL SIGNATURES COMPLETED	

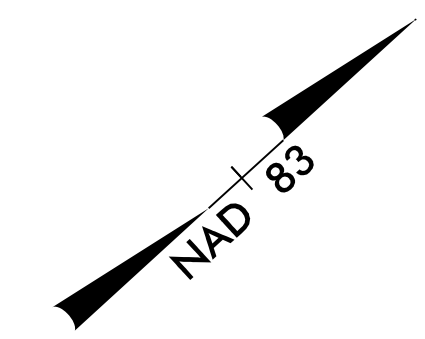

MATCHLINE -L- STA. 274 + 00
SEE SHEET PMP-22

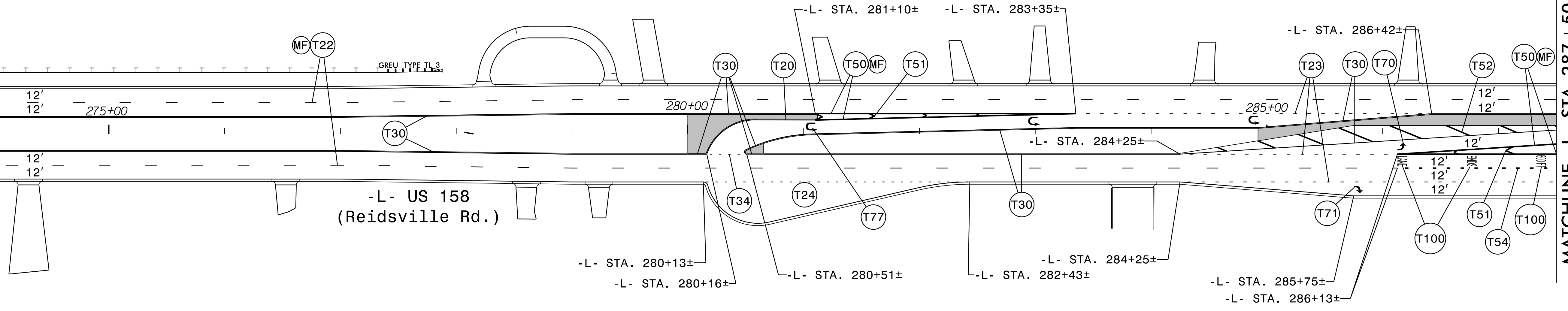

MATCHLINE -L- STA. 287 + 50
SEE SHEET PMP-24

R:\2024\2577A_PMP-23.dgn

RK&K
 P: (919) 878-9550
 6601 Six Forks Road, Forum 1, Suite 700
 Raleigh, North Carolina 27615-3960
 NC License No. F-0112
 Engineers | Construction Managers | Planners | Scientists
 www.rkk.com
 Responsive People | Creative Solutions

PAVEMENT MARKING DETAIL

APPROVED: *David J. Sears*
089183F28E5741E
 DATE: 3/7/2024

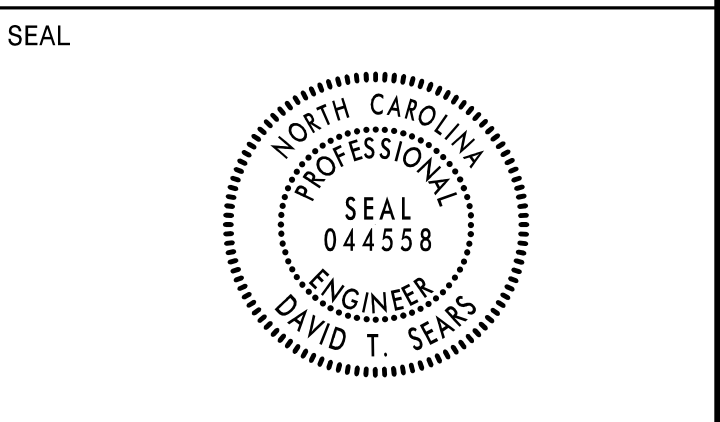

**DOCUMENT NOT CONSIDERED FINAL
UNLESS ALL SIGNATURES COMPLETED**

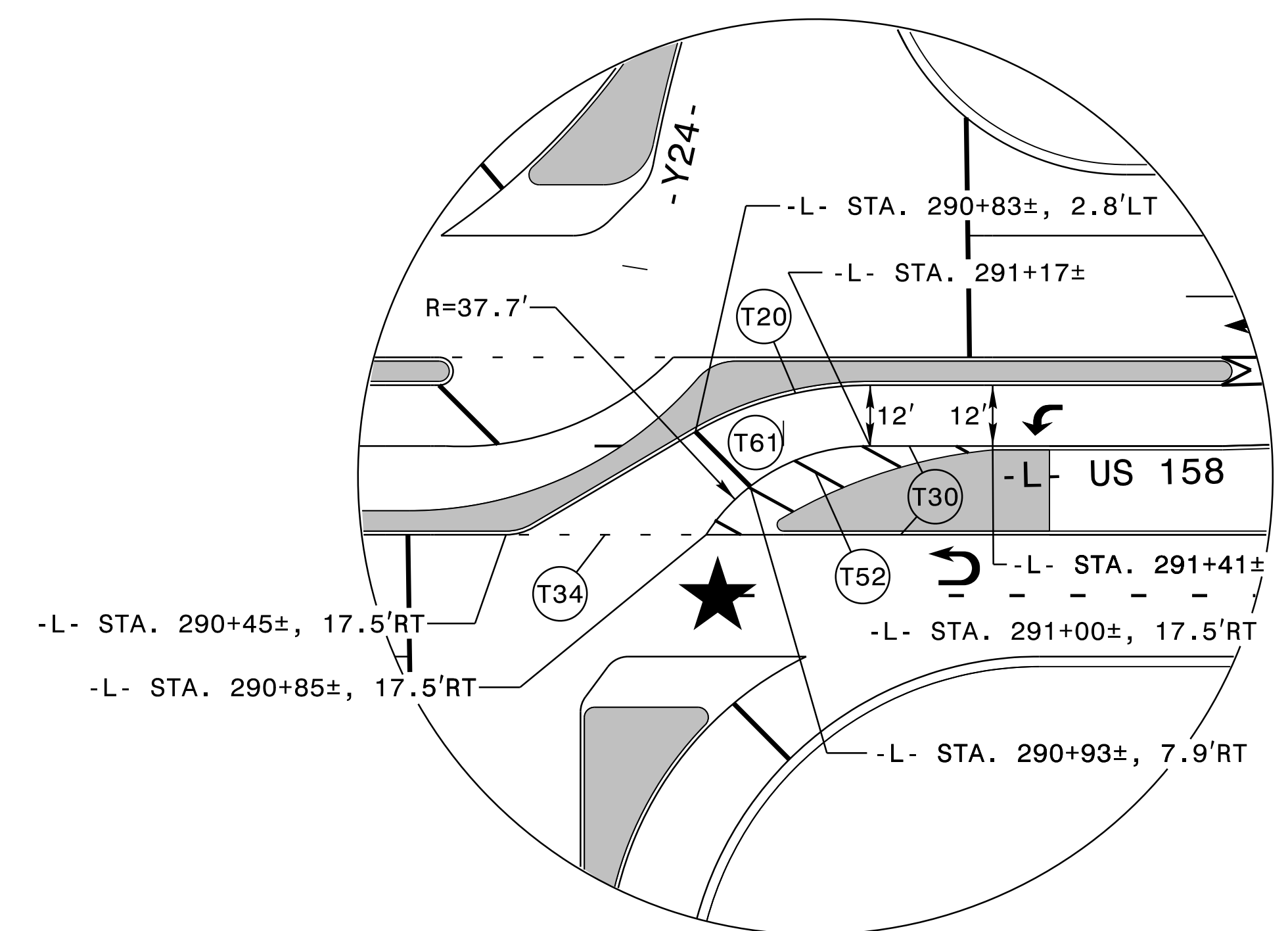
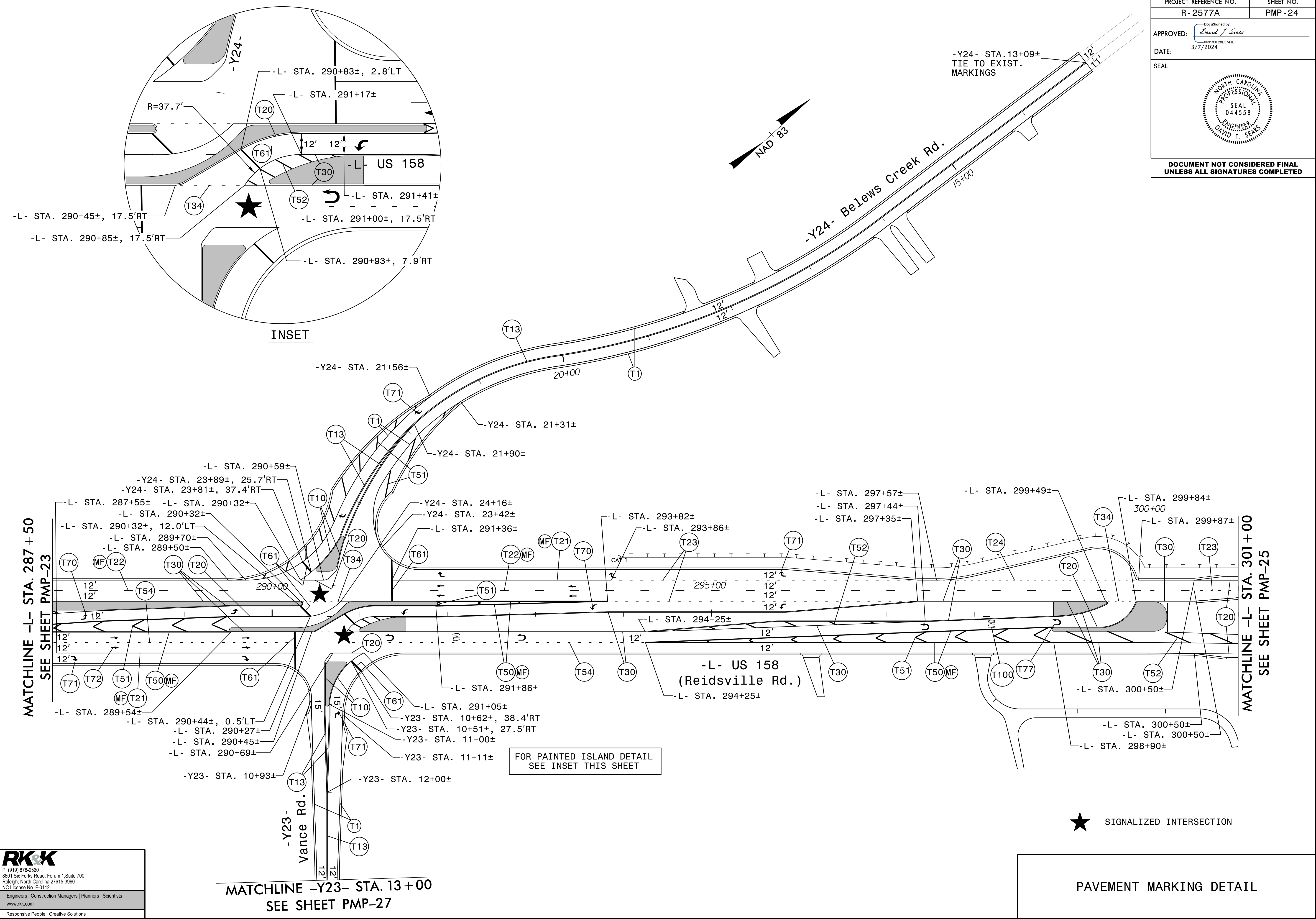

FOR PAINTED ISLAND DETAIL
SEE INSET THIS SHEET

★ SIGNALIZED INTERSECTION

PAVEMENT MARKING DETAIL

MATCHLINE -Y23- STA. 13+00
SEE SHEET PMP-27

MATCHLINE -L- STA. 287+50
SEE SHEET PMP-23

MATCHLINE -L- STA. 301+00
SEE SHEET PMP-25

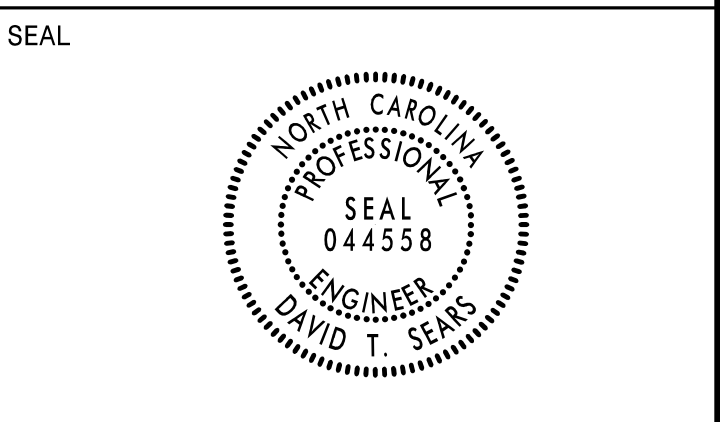

**DOCUMENT NOT CONSIDERED FINAL
 UNLESS ALL SIGNATURES COMPLETED**

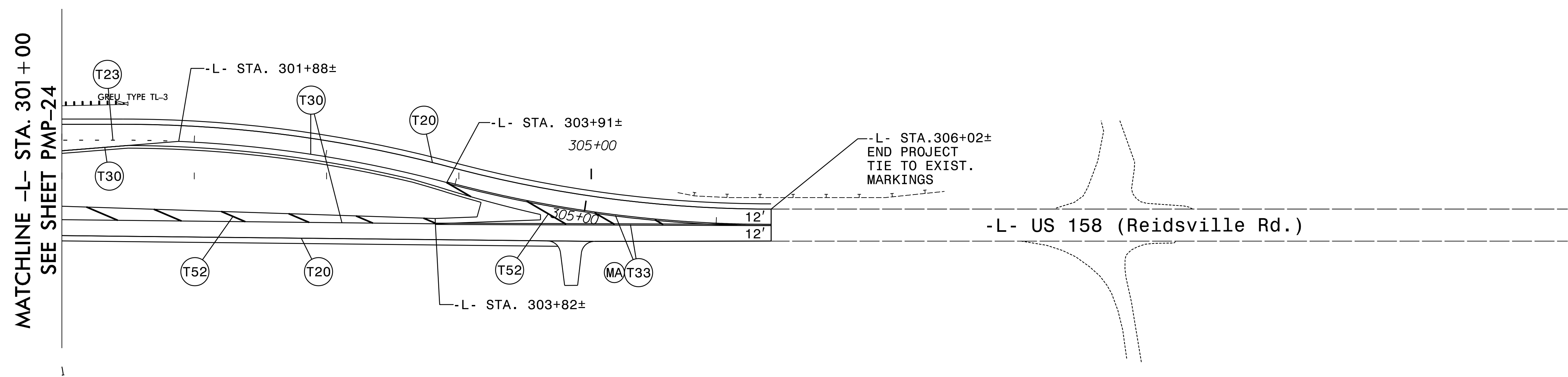
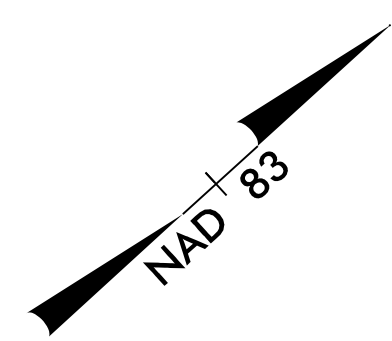

R:\2024\2577A_PMP-25.dgn

RKK
 P: (919) 878-9550
 6601 Six Forks Road, Forum 1, Suite 700
 Raleigh, North Carolina 27615-3960
 NC License No. F-0112

Engineers | Construction Managers | Planners | Scientists
www.rkk.com

Responsive People | Creative Solutions

PAVEMENT MARKING DETAIL

PROJECT REFERENCE NO. R-2577A	SHEET NO. PMP-26
APPROVED: <i>David T. Sears</i> 089183F28E5741E DATE: 3/7/2024	
SEAL	
	
DOCUMENT NOT CONSIDERED FINAL UNLESS ALL SIGNATURES COMPLETED	

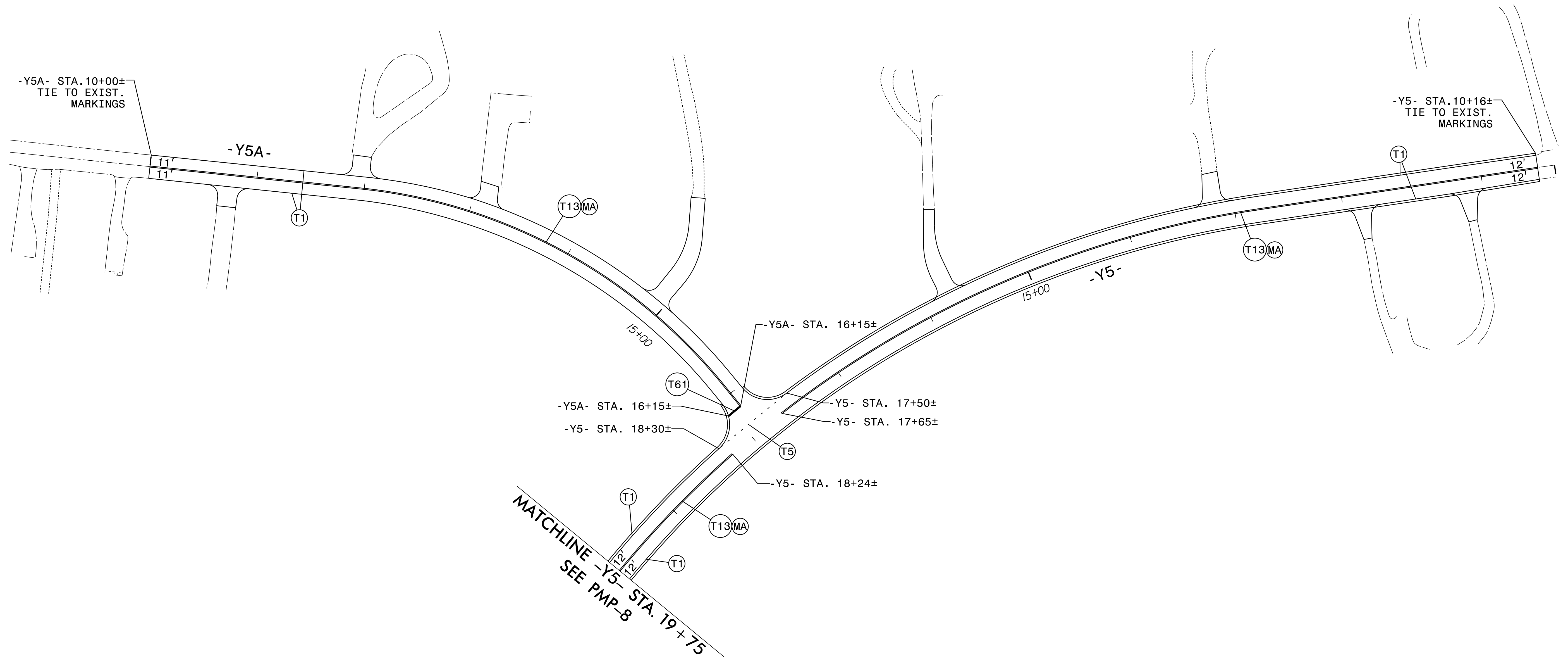

RK&K
 P: (919) 878-9550
 6601 Six Forks Road, Forum 1, Suite 700
 Raleigh, North Carolina 27615-3960
 NC License No. F-0112
 Engineers | Construction Managers | Planners | Scientists
 www.rkk.com
 Responsive People | Creative Solutions

PAVEMENT MARKING DETAIL

R:\2024\2577A_PMP-26.dgn

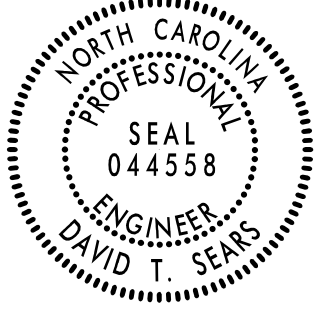
PROJECT REFERENCE NO.	SHEET NO.
R-2577A	PMP-27
APPROVED: <i>David T. Sears</i>	
DATE: 3/7/2024	
SEAL	
	
DOCUMENT NOT CONSIDERED FINAL UNLESS ALL SIGNATURES COMPLETED	

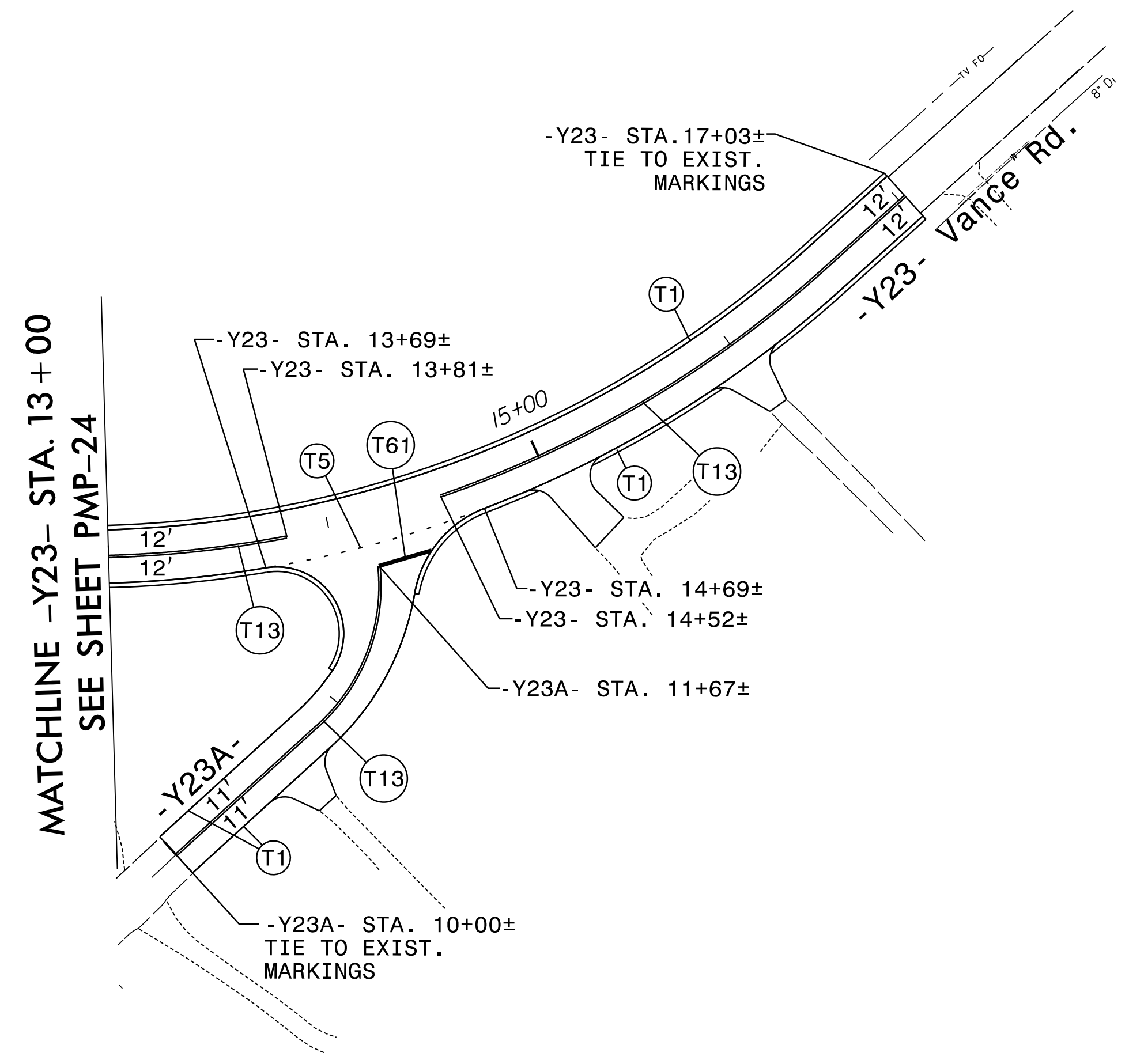
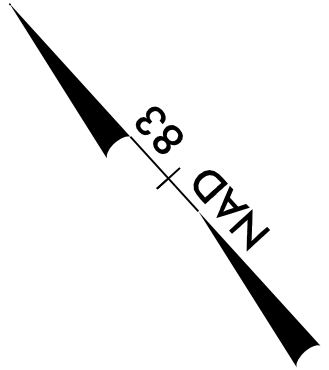

R:\2577A_PMP-27.dgn

RKK
 P: (919) 878-9550
 6601 Six Forks Road, Forum 1, Suite 700
 Raleigh, North Carolina 27615-3960
 NC License No. F-0112

Engineers | Construction Managers | Planners | Scientists
www.rkk.com

Responsive People | Creative Solutions

PAVEMENT MARKING DETAIL