

UTILITY CONSTRUCTION
DOCUMENT NOT CONSIDERED FINAL
UNLESS ALL SIGNATURES COMPLETED

PROJECT TYPICAL DETAILS

Polymer Concrete Meter Box for 1 1/2" and 2" Meters

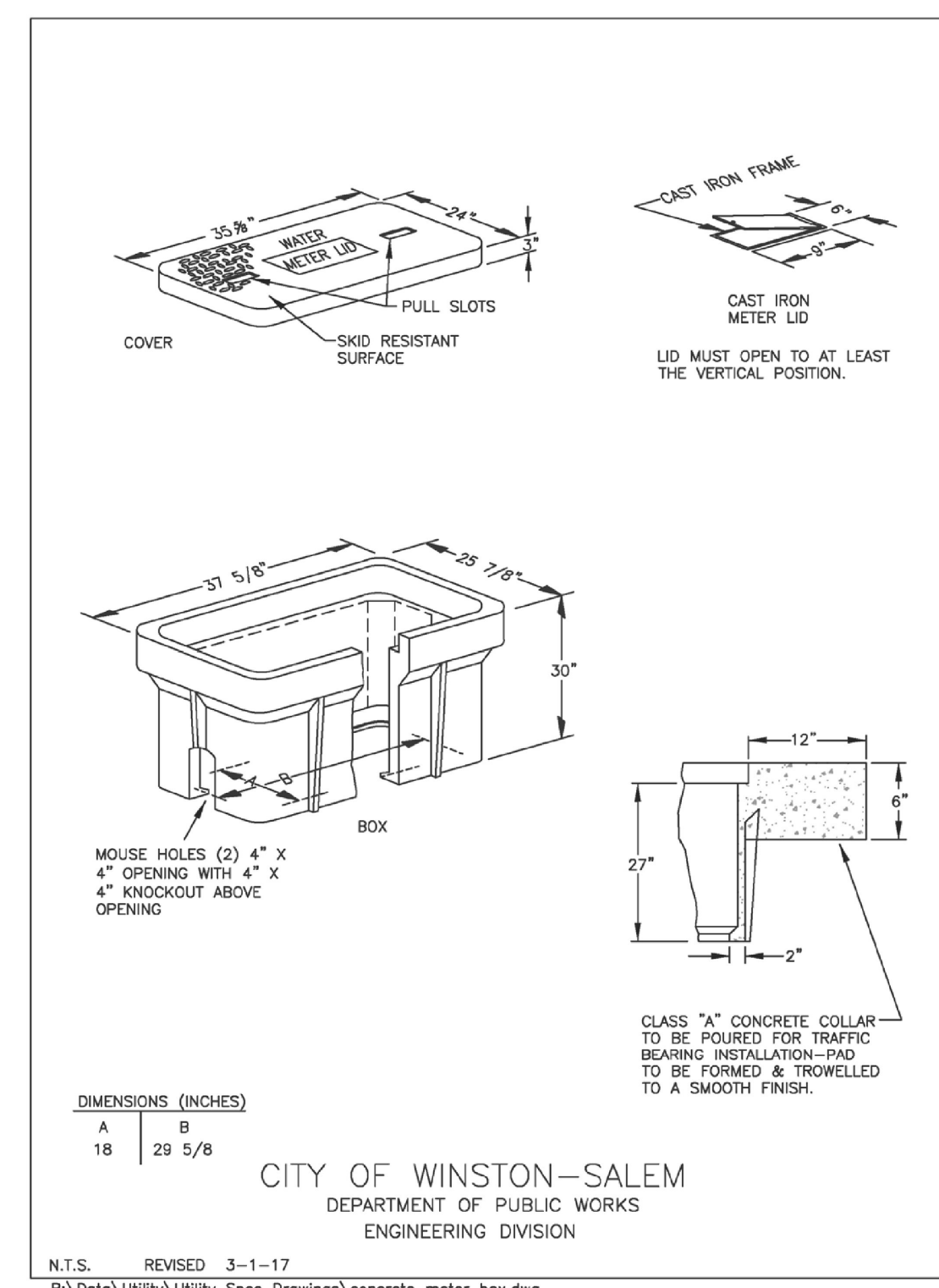

C-50

Air Release Valve (Section View)

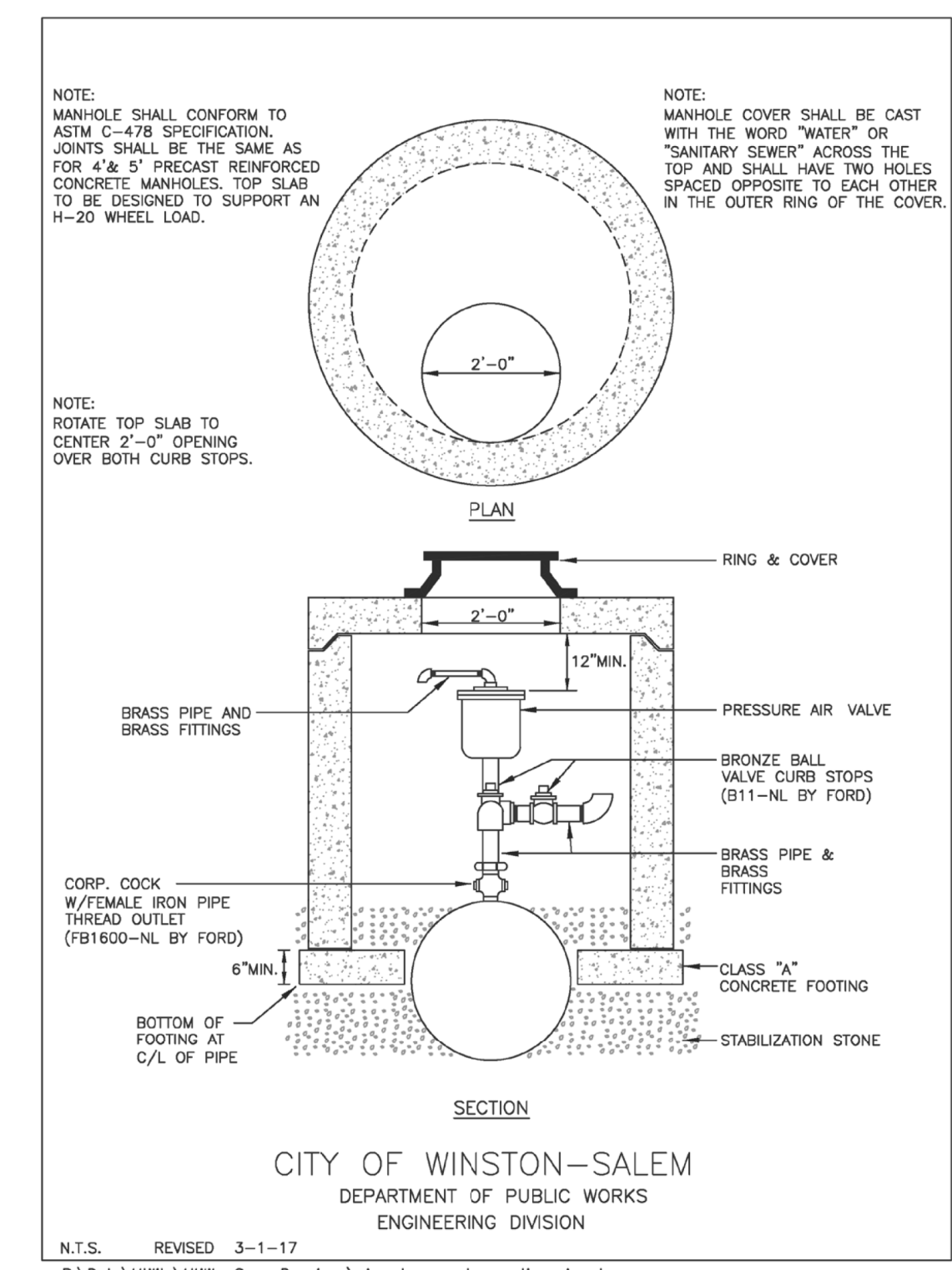

C-52

Air Release Valve (Profile View)

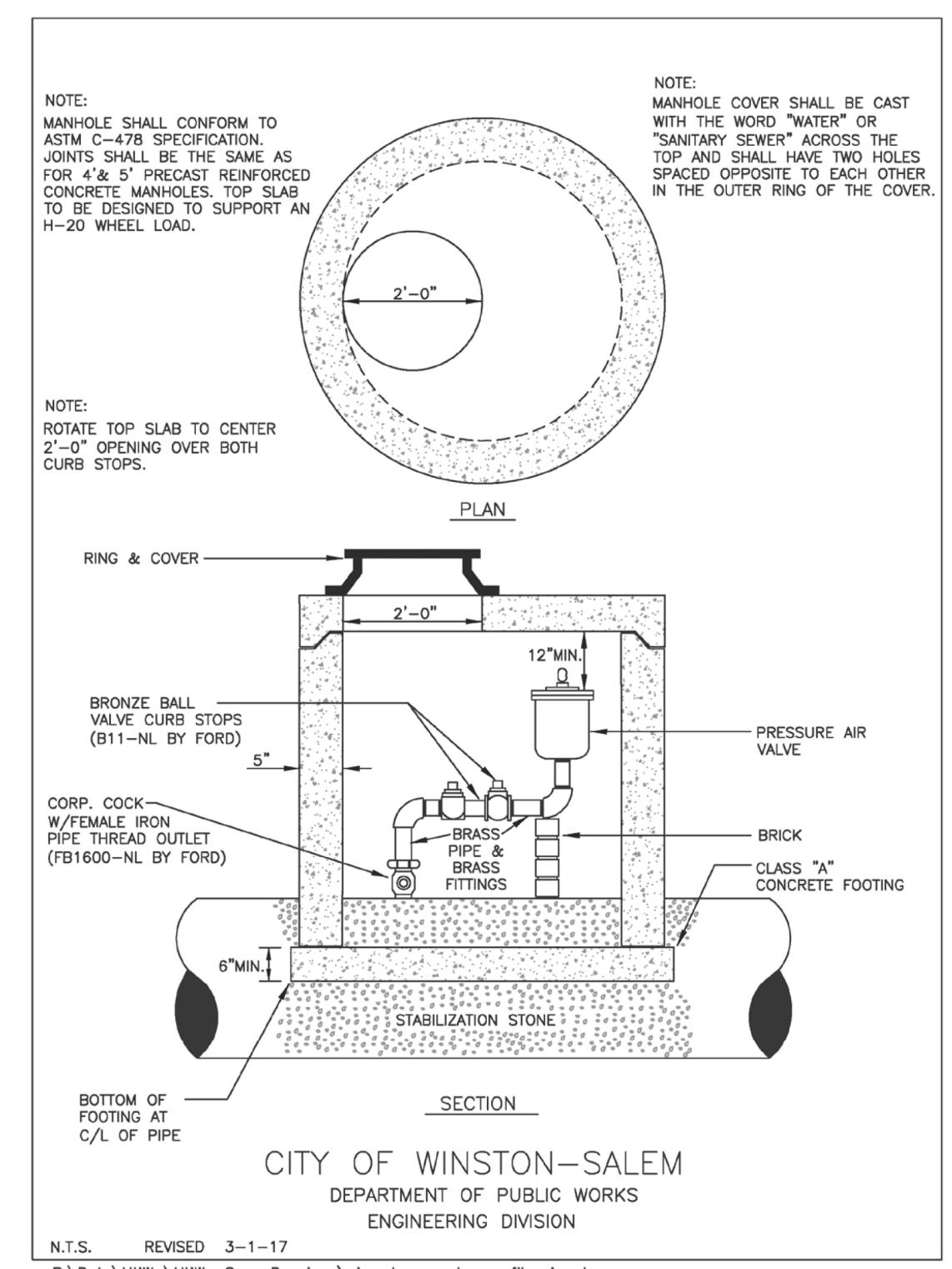

C-53

THRUST HARNESS FOR EXISTING PIPE

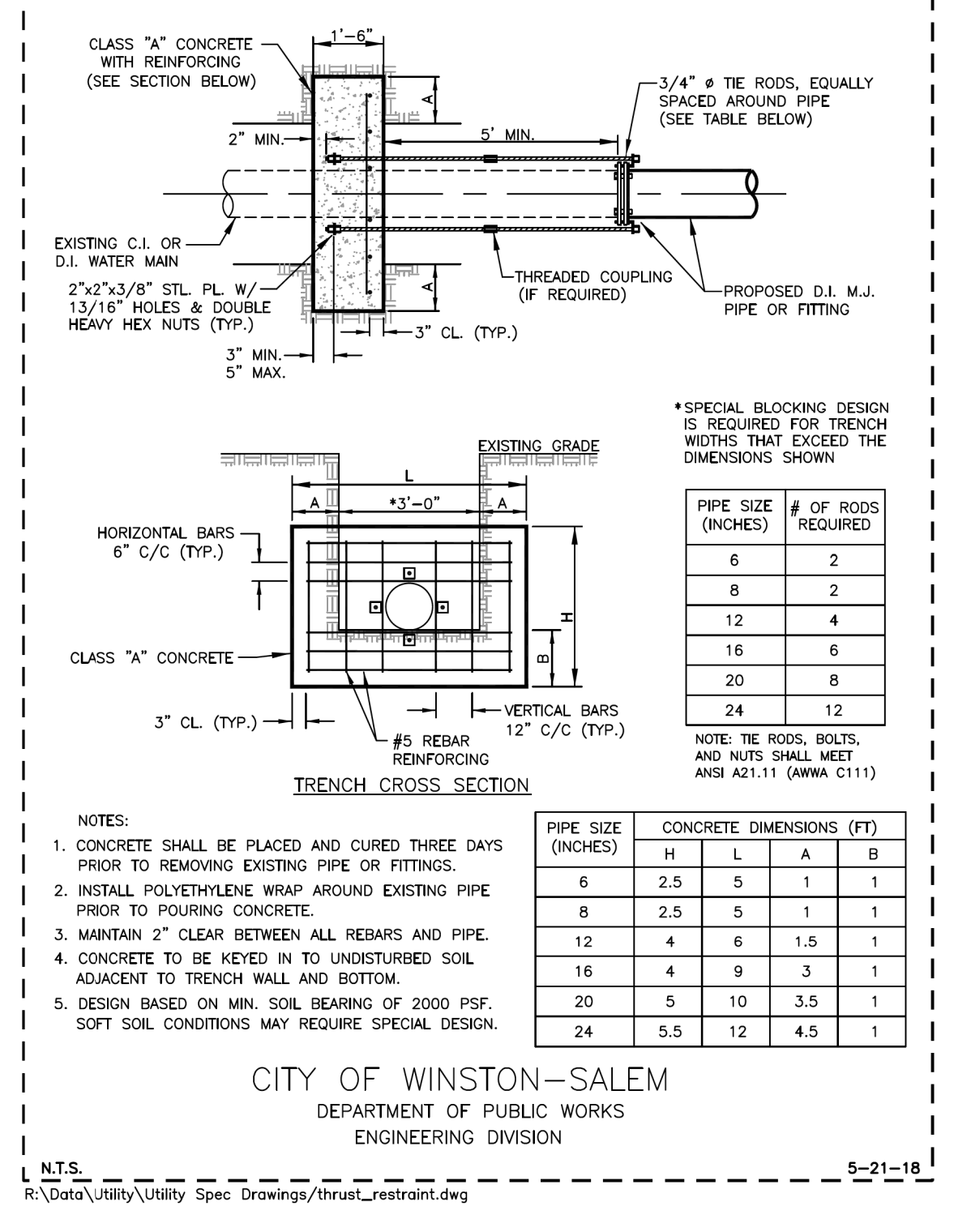

5-21-18

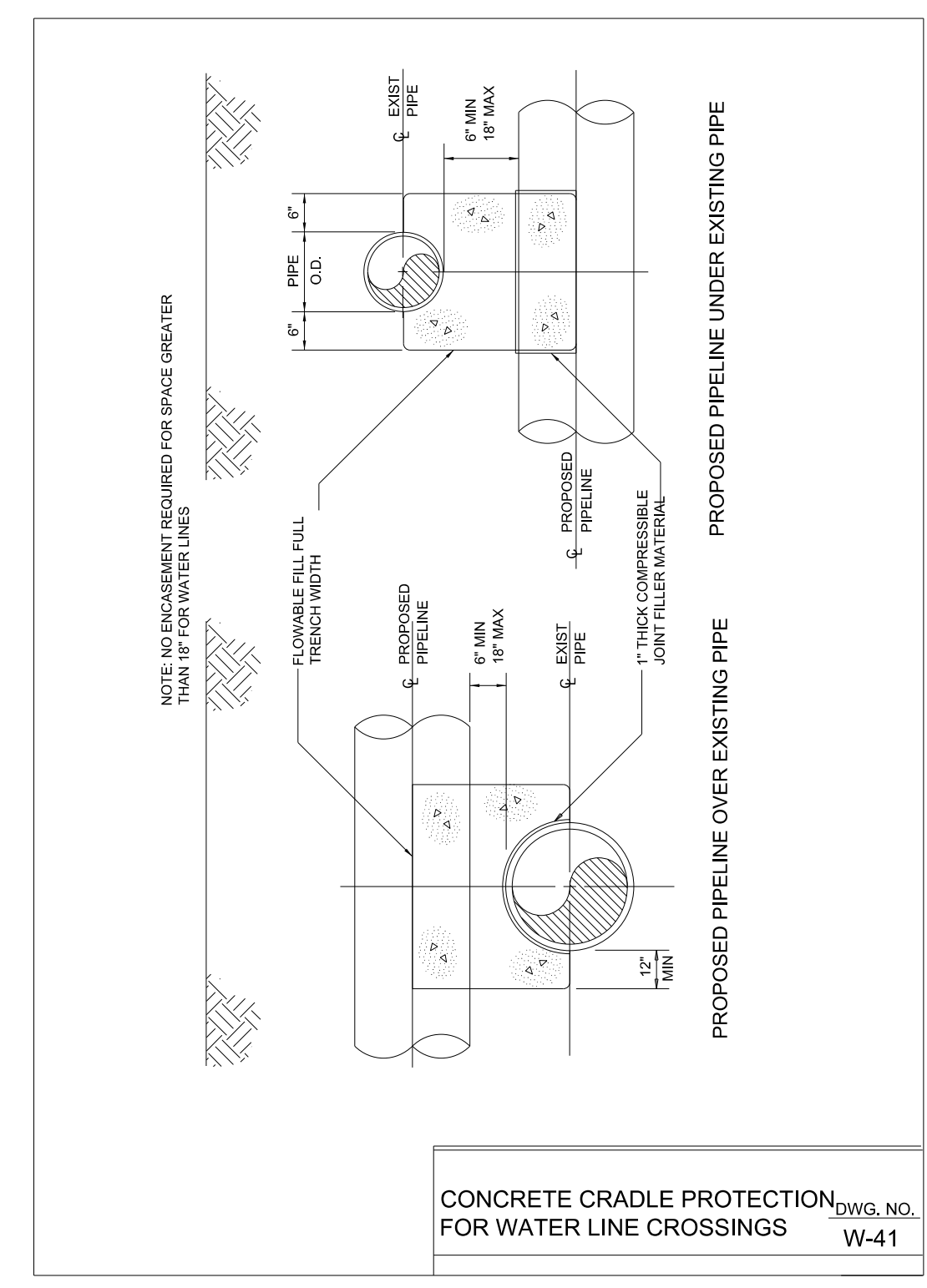

R:\Data\Utility\Utility Spec Drawings\UC\Proc\N-2577A_Utl.dtl.psh@30.dwg