

PROJECT TYPICAL DETAILS

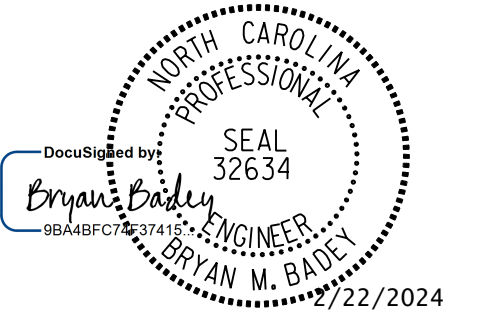

UTILITY CONSTRUCTION
DOCUMENT NOT CONSIDERED FINAL
UNLESS ALL SIGNATURES COMPLETED

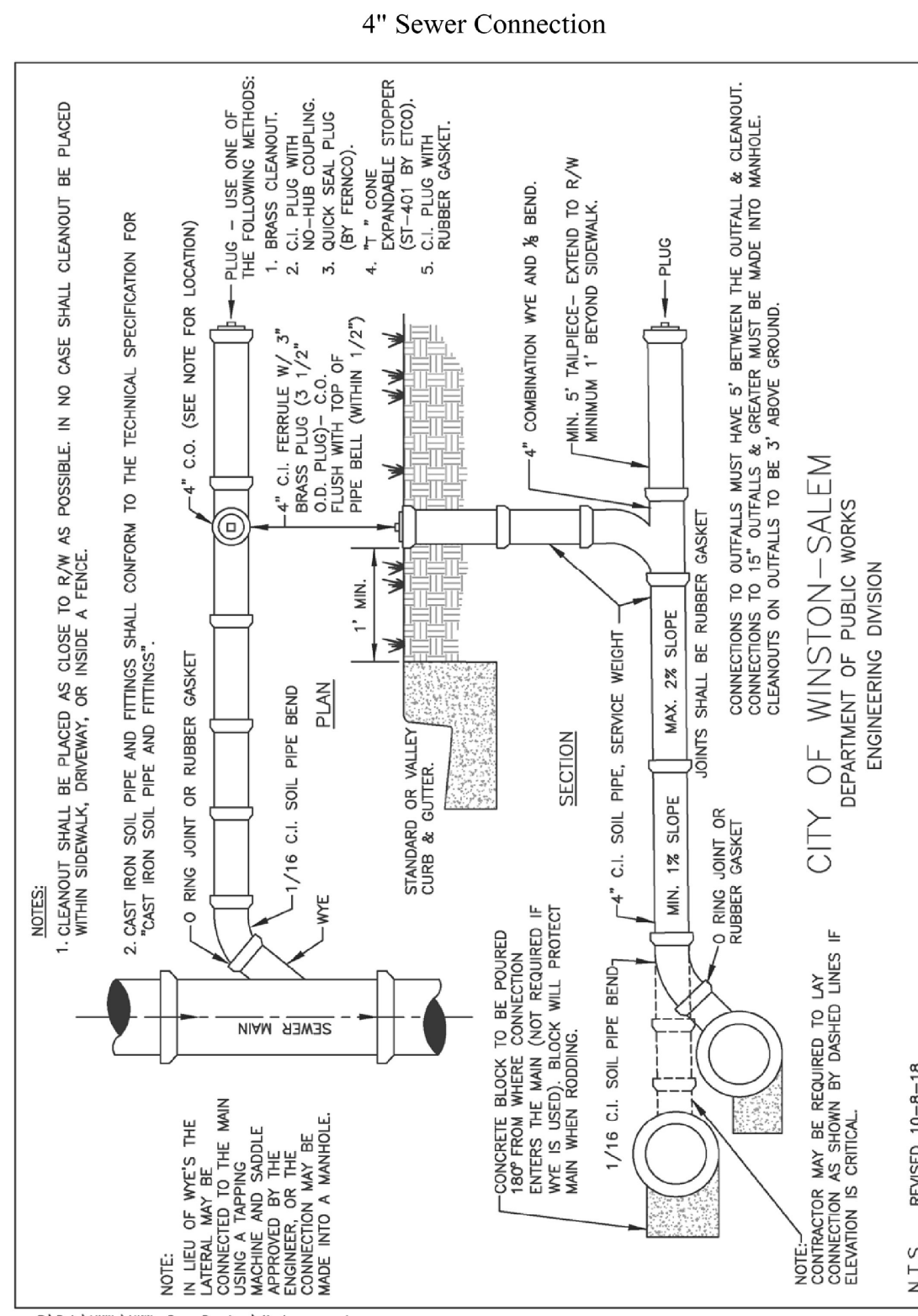

C-22

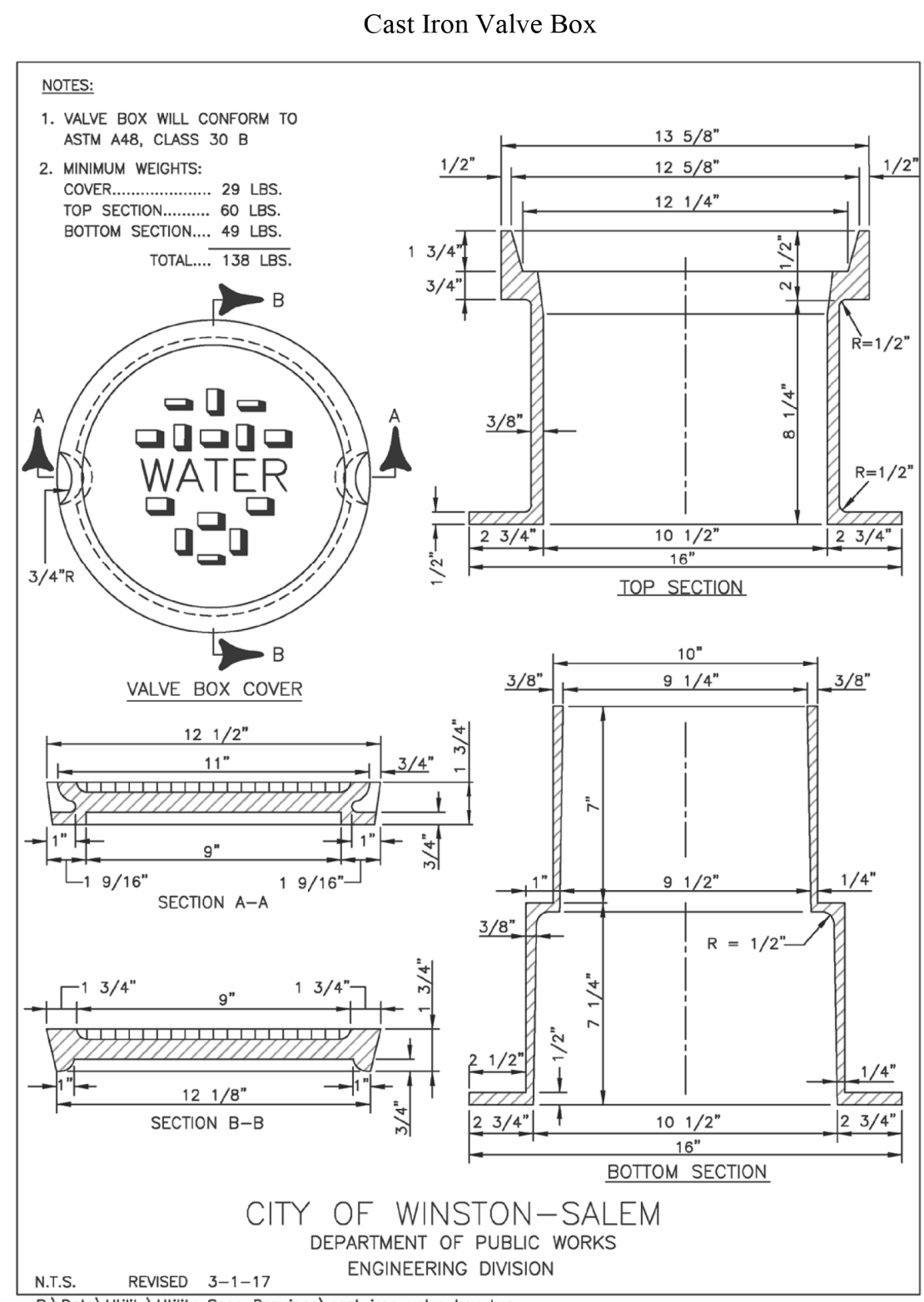

C-39

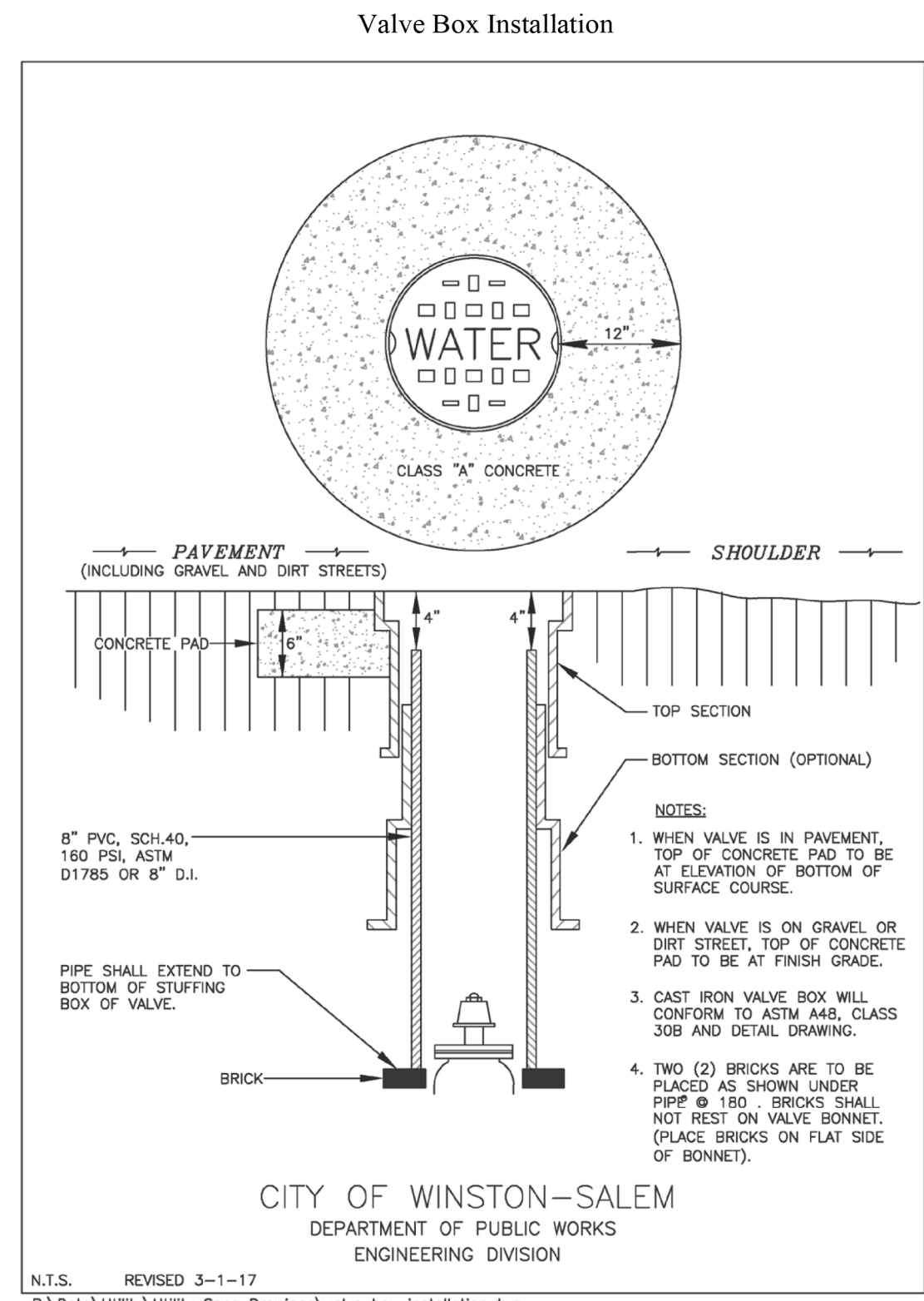

C-40

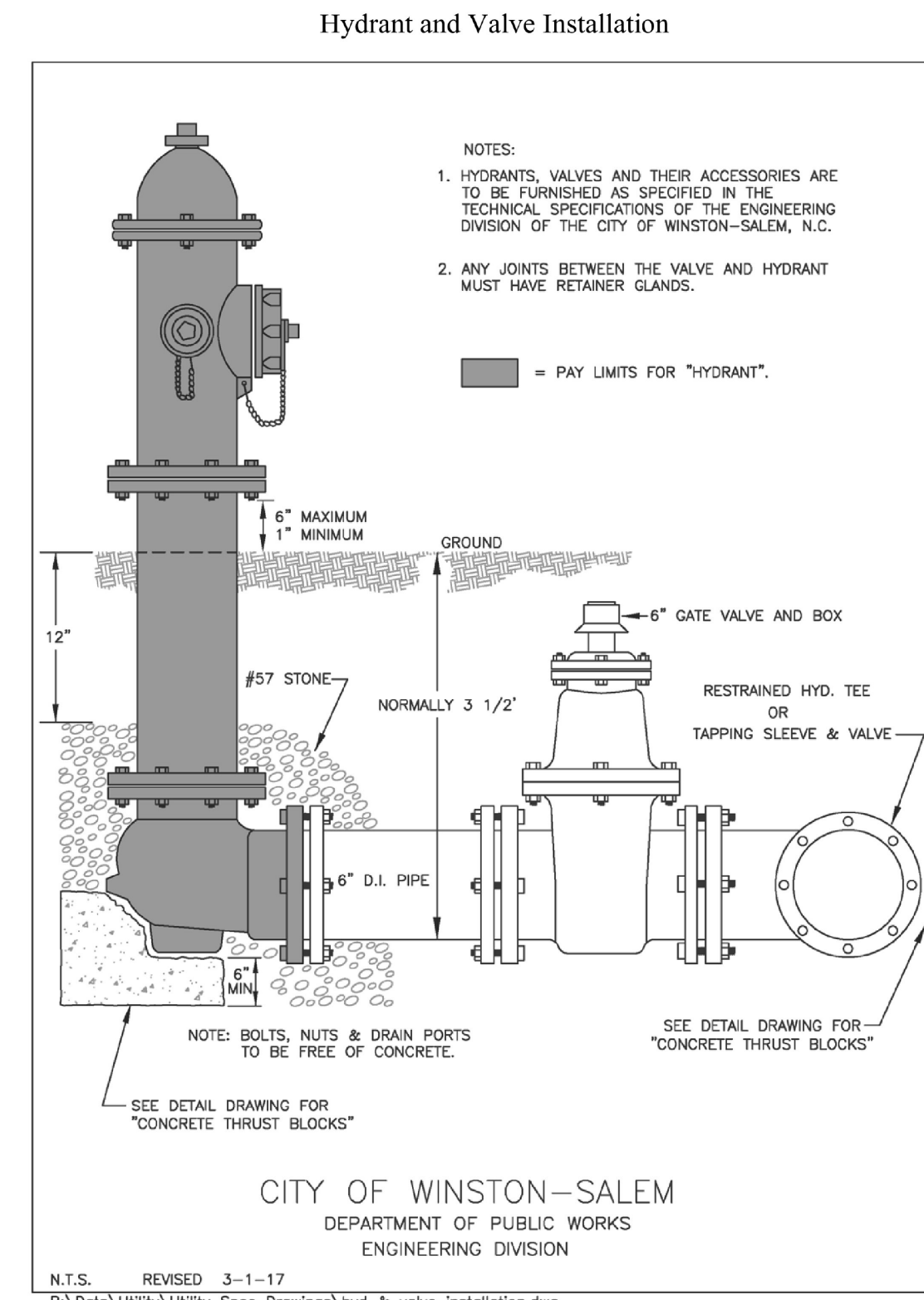

C-41

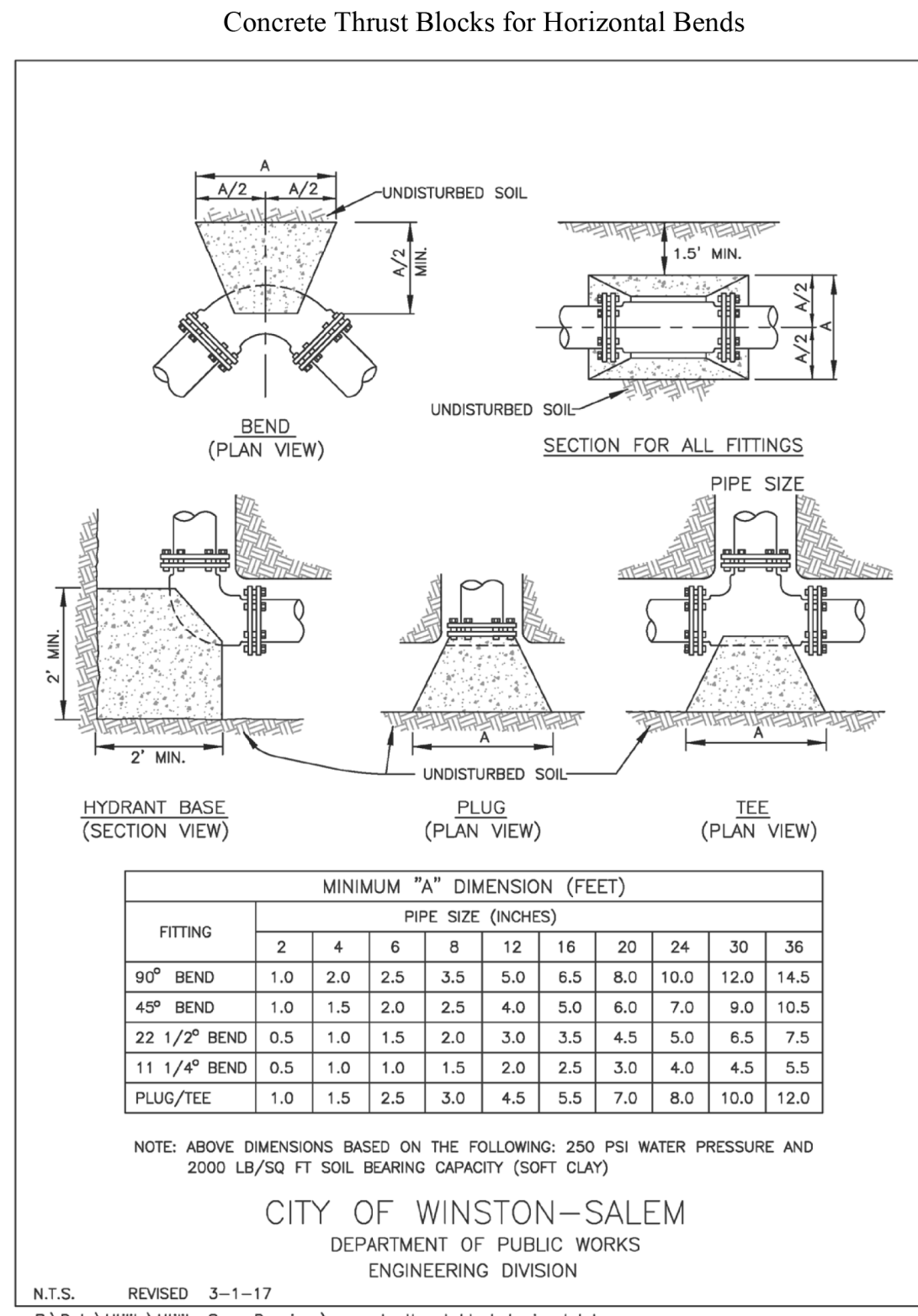

C-43

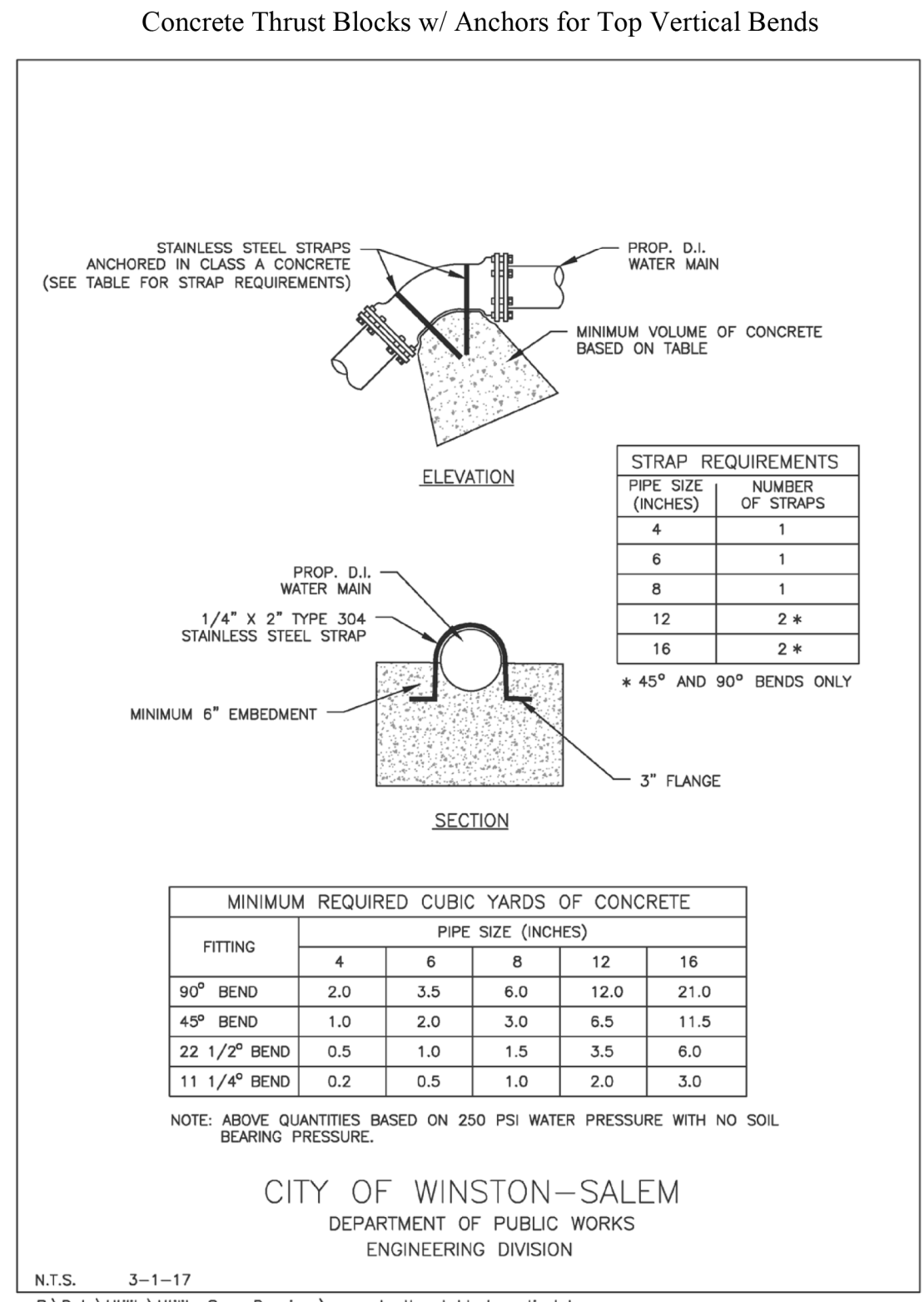

C-44

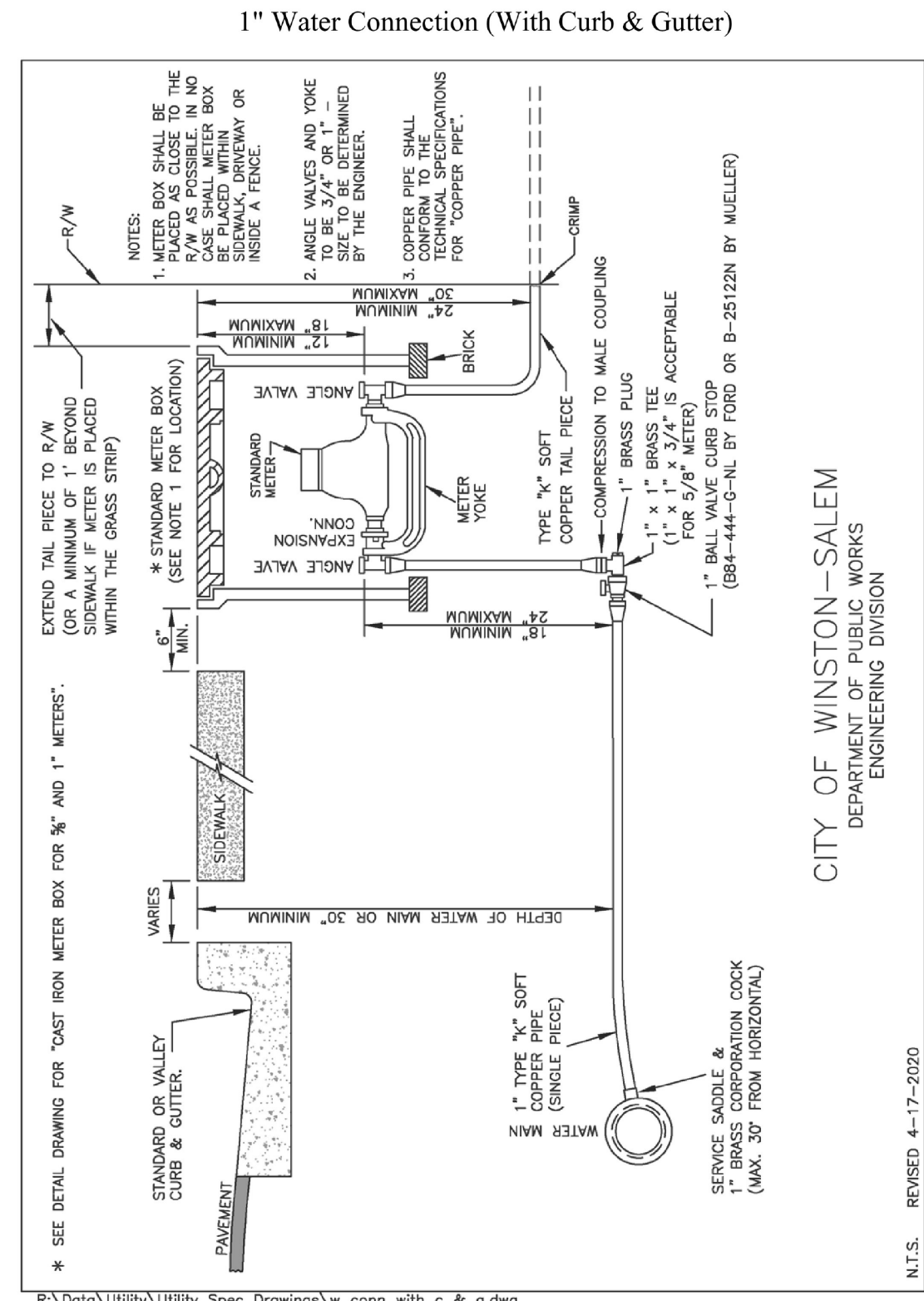

C-46

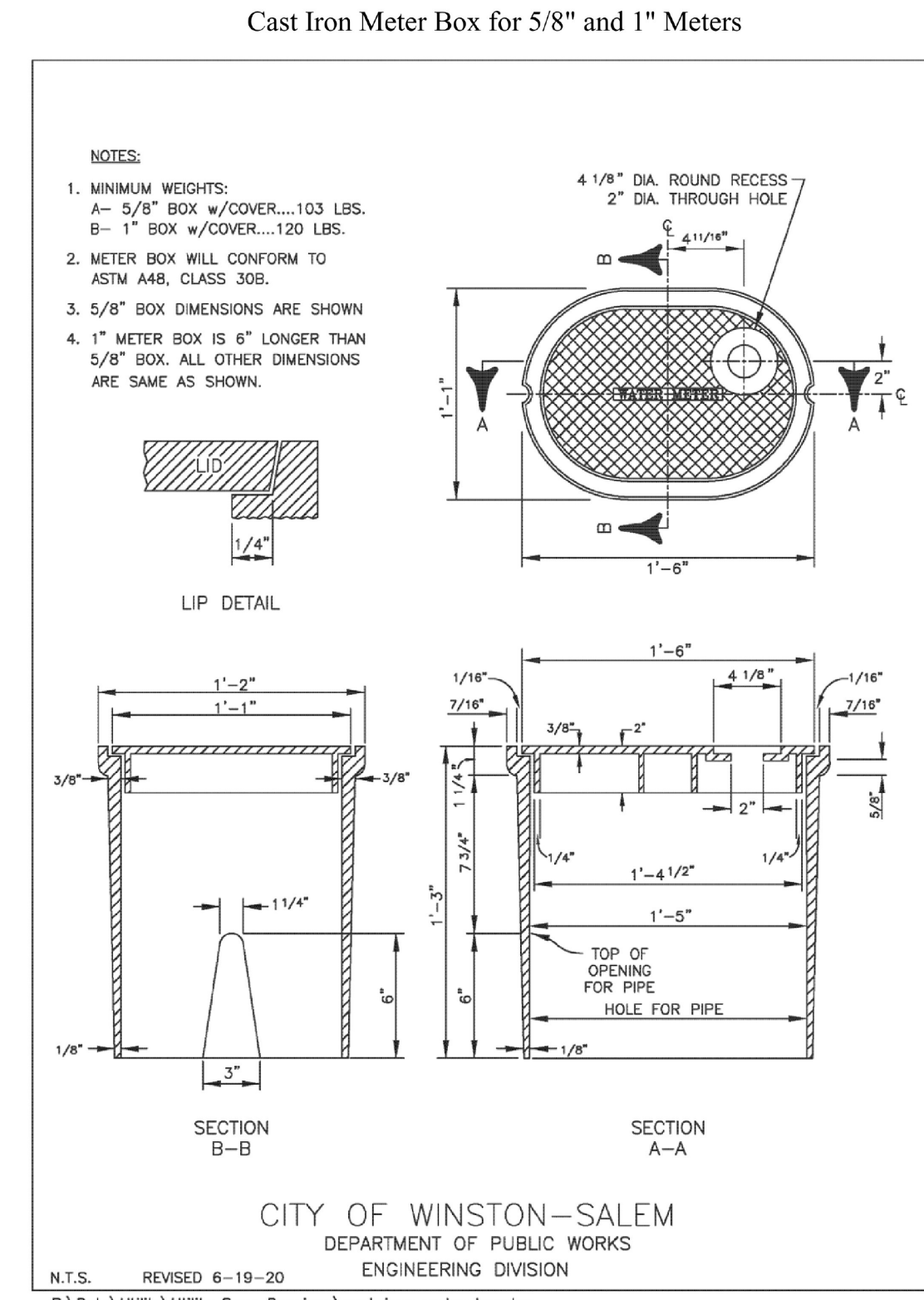

C-49

