

**18 CHANNEL IP CONFLICT MONITOR PROGRAMMING DETAIL**

(remove jumpers and set switches as shown)

REMOVE DIODE JUMPERS 1-5, 1-6, 1-9, 1-11, 2-5, 2-6, 2-9, 2-11, 3-7, 3-8, 3-10, 3-12, 4-7, 4-8, 4-10, 4-12, 5-9, 5-11, 6-9, 6-11, 7-10, 7-12, 8-10, 8-12, 9-11 and 10-12.

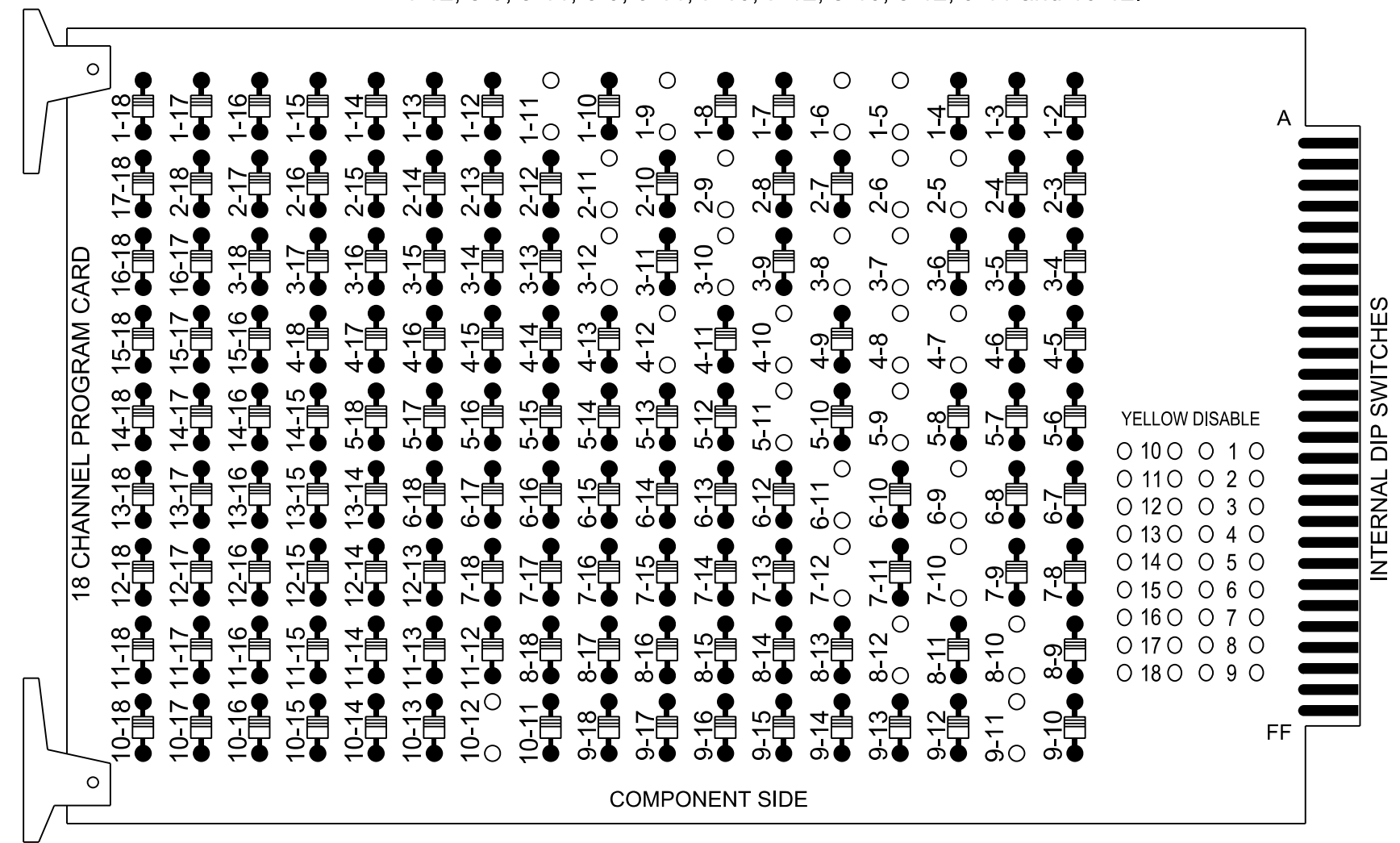

REMOVE JUMPERS AS SHOWN

**NOTES:**

1. Card is provided with all diode jumpers in place. Removal of any jumper allows its channels to run concurrently.
2. Ensure jumpers SEL2-SEL5 and SEL9 are present on the monitor board.
3. Ensure that the Red Enable is active at all times during normal operation.
4. Connect serial cable from conflict monitor to comm. port 1 of 2070 controller. Ensure conflict monitor communicates with 2070.

**NOTES**

1. To prevent "flash-conflict" problems, insert red flash program blocks for all unused vehicle load switches in the output file. The installer shall verify that signal heads flash in accordance with the signal plan.
2. Program phases 4 and 8 for Dual Entry.
3. Program controller to start up in phase 2 Green No Walk and 6 Green No Walk.
4. If this signal will be managed by an ATMS software, enable controller and detector logging for all detectors used at this location.

**EQUIPMENT INFORMATION**

Controller.....2070LX  
 Cabinet.....332 w/ Aux  
 Software.....Q-Free MAXTIME  
 Cabinet Mount.....Base  
 Output File Positions.....18 With Aux. Output File  
 Load Switches Used.....S1, S2, S4, S5, S7, S8, S10, S11, AUX S1, AUX S2, AUX S4, AUX S5  
 Phases Used.....1, 2, 3, 4, 5, 6, 7, 8  
 Overlap "1".....\*  
 Overlap "2".....\*  
 Overlap "3".....\*  
 Overlap "4".....\*

\*See overlap programming detail on sheet 2.

**SIGNAL HEAD HOOK-UP CHART**

LOAD SWITCH NO.	S1	S2	S3	S4	S5	S6	S7	S8	S9	S10	S11	S12	AUX S1	AUX S2	AUX S3	AUX S4	AUX S5	AUX S6
CMU CHANNEL NO.	1	2	13	3	4	14	5	6	15	7	8	16	9	10	17	11	12	18
PHASE	1	2	2 PED	3	4	4 PED	5	6	6 PED	7	8	8 PED	OL1	OL2	SPARE	OL3	OL4	SPARE
SIGNAL HEAD NO.	11*	82	21,22	22	31*	41,42,43	51*	61,62	62	71*	81,82	82	11*	31*	51*	71*	71*	NU
RED	*	128		*	101		134		*	107								
YELLOW		129			102		*	135		108								
GREEN		130			103		136			109								
RED ARROW													A121	A124		A114	A101	
YELLOW ARROW	126			117						123			A122	A125		A115	A102	
FLASHING YELLOW ARROW													A123	A126		A116	A103	
GREEN ARROW	127	127		118	118		133		124	124								

NU = Not Used  
 \* Denotes install load resistor. See load resistor installation detail this sheet.  
 \*See pictorial of head wiring in detail this sheet.

**INPUT FILE POSITION LAYOUT**

(front view)

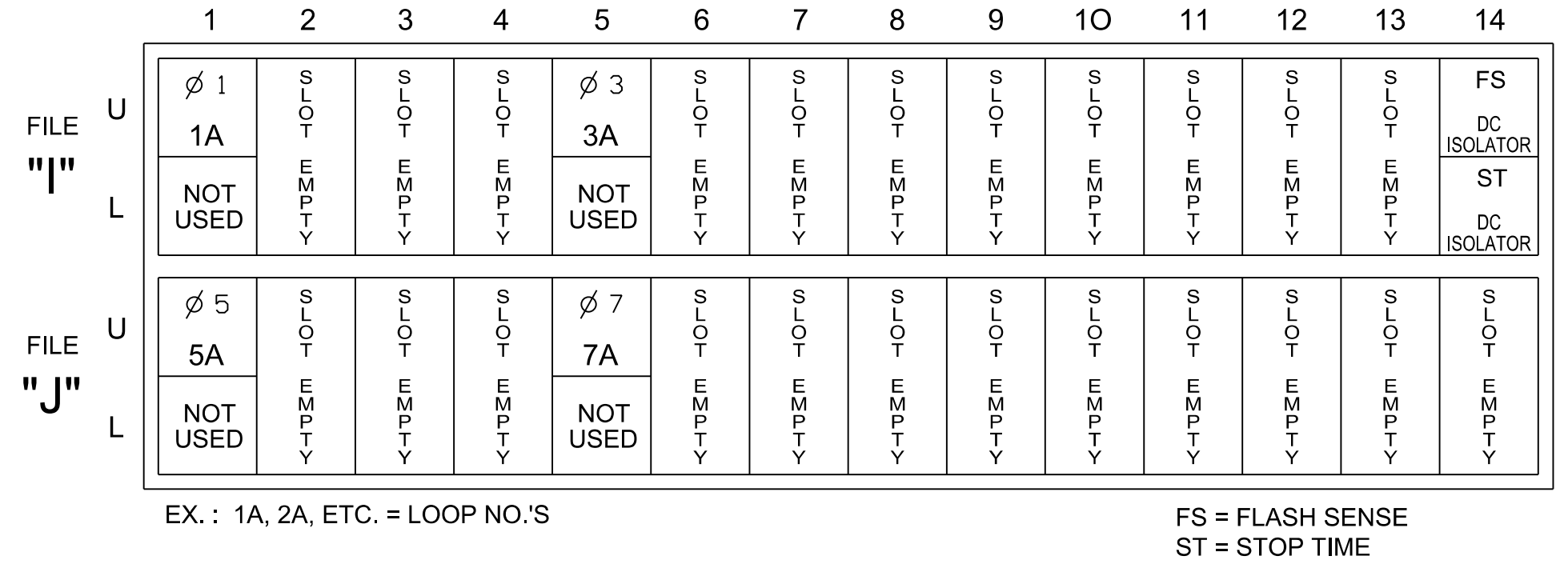

**INPUT FILE CONNECTION & PROGRAMMING CHART**

LOOP NO.	LOOP TERMINAL	INPUT FILE POS.	PIN NO.	INPUT POINT	DETECTOR NO.	CALL PHASE	DELAY TIME	EXTEND TIME	EXTEND	ADDED INITIAL	CALL	DELAY DURING GREEN
1A	TB2-1,2	I1U	56	18	1	★	15		X		X	
				-	29	★	3		X		X	X
3A	TB4-5,6	I5U	58	20	7	★	15		X		X	
				-	30	★	3		X		X	
5A	TB3-1,2	J1U	55	17	15	★	15		X		X	
				-	31	★	3		X		X	X
7A	TB5-5,6	J5U	57	19	21	★	15		X		X	
				-	32	★	3		X		X	

★ For the detector to work as shown on the signal design plan, see the vehicle detector setup programming detail for alternate phasing on sheet 2.

**INPUT FILE POSITION LEGEND: J2L**

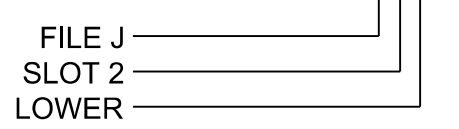

**FYA SIGNAL WIRING DETAIL**

(wire signal heads as shown)

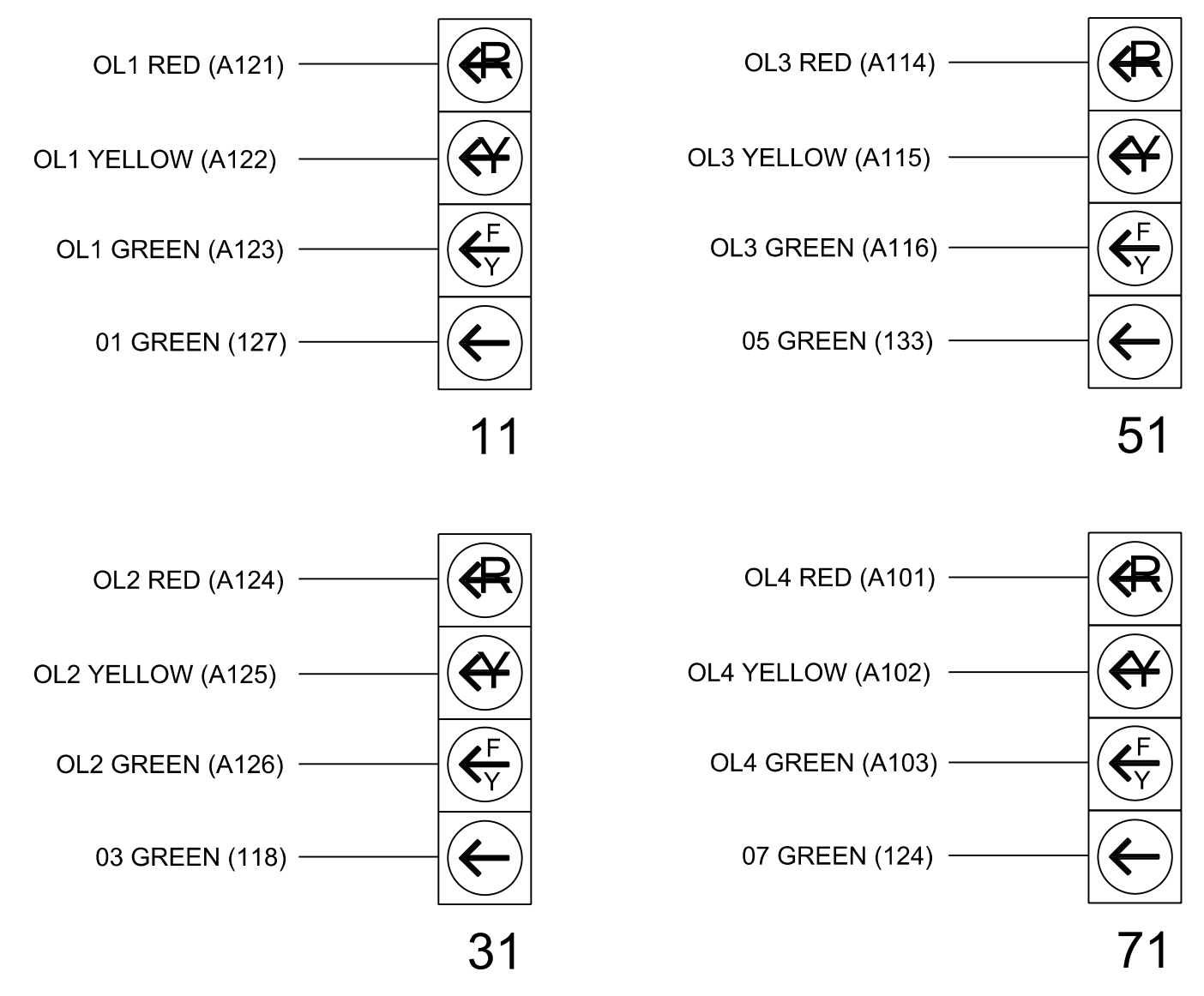

**LOAD RESISTOR INSTALLATION DETAIL**

(install resistors as shown)

Value (ohms)	Wattage
1.5K - 1.9K	25W (min)
2.0K - 3.0K	10W (min)

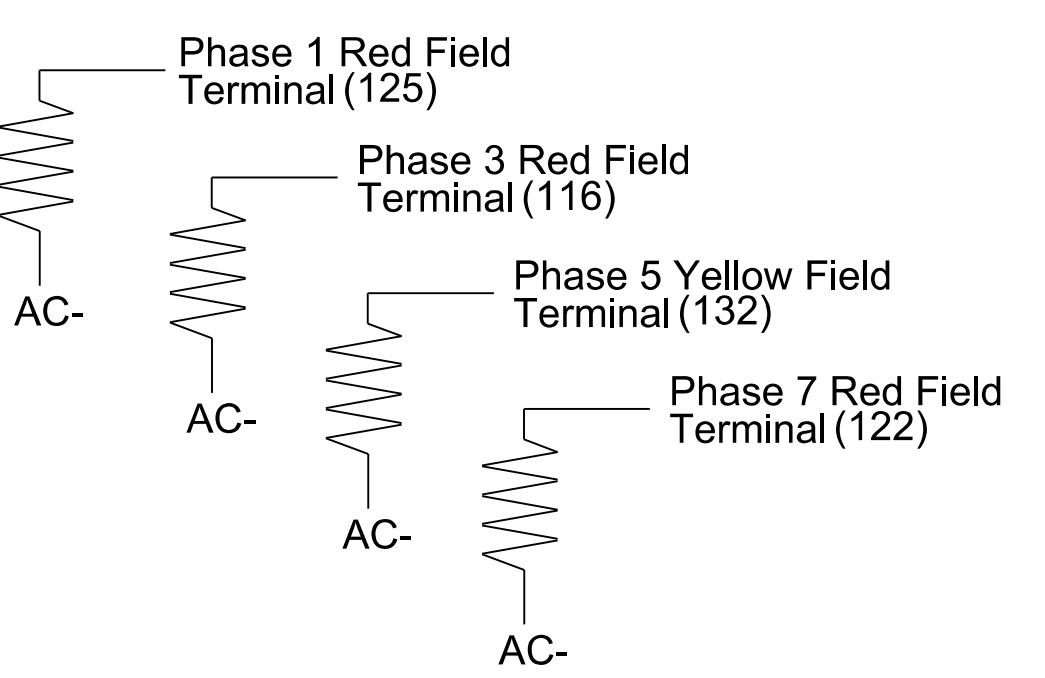

**SPECIAL DETECTOR NOTE**

Install a video detection system for vehicle detection for zones. 1A, 1B, 2A, 3A, 4A, 5A, 6A, 7A and 8A. Perform installation according to manufacturer's directions and NCDOT engineer-approved mounting locations to accomplish the detection schemes shown on the Signal Design Plans.

For detecton zones 1A, 3A, 5A, and 7A, detector card placement and slots are typical for a NCDOT installation. Inputs associated with these slots are compatible with time of day instructions located on sheet 2 of this electrical detail.

THIS ELECTRICAL DETAIL IS FOR THE SIGNAL DESIGN: 09-0264T2  
 DESIGNED: February 2024  
 SEALED: February 12, 2024  
 REVISED:

Signal Upgrade - Temporary Design 2 (TMP Phase II) - Electrical Detail - Sheet 1 of 2

Electrical and Programming Details For: US 158 (Reidsville Rd.) at NC 66 (Old Hollow Rd.)

Prepared for the Offices of: [Seal of the State of North Carolina]

Division 9 Forsyth County Walkertown  
 PLAN DATE: February 2024 REVIEWED BY: DT Sears  
 PREPARED BY: WP Erickson-Jones REVIEWED BY:

REVISIONS: [Table with columns for REVISIONS, INIT., DATE]

750 N. Greenfield Pkwy, Garner, NC 27529  
 (919) 878-9560  
 8801 Six Forks Road Suite 700 | Raleigh, North Carolina 27615-2965  
 NC License No. F-0112  
 www.rk.com  
 Responsive People | Creative Solutions

DOCUMENT NOT CONSIDERED FINAL UNLESS ALL SIGNATURES COMPLETED

SEAL NORTH CAROLINA PROFESSIONAL ENGINEER PORTER JONES

Porter Jones 2/12/2024

SIG. INVENTORY NO. 09-0264T2