

18 CHANNEL CONFLICT MONITOR PROGRAMMING DETAIL

(remove jumpers and set switches as shown)

REMOVE DIODE JUMPERS 1-3, 1-9, 1-10, 3-9, 3-10, 6-9, 6-10 AND 9-10

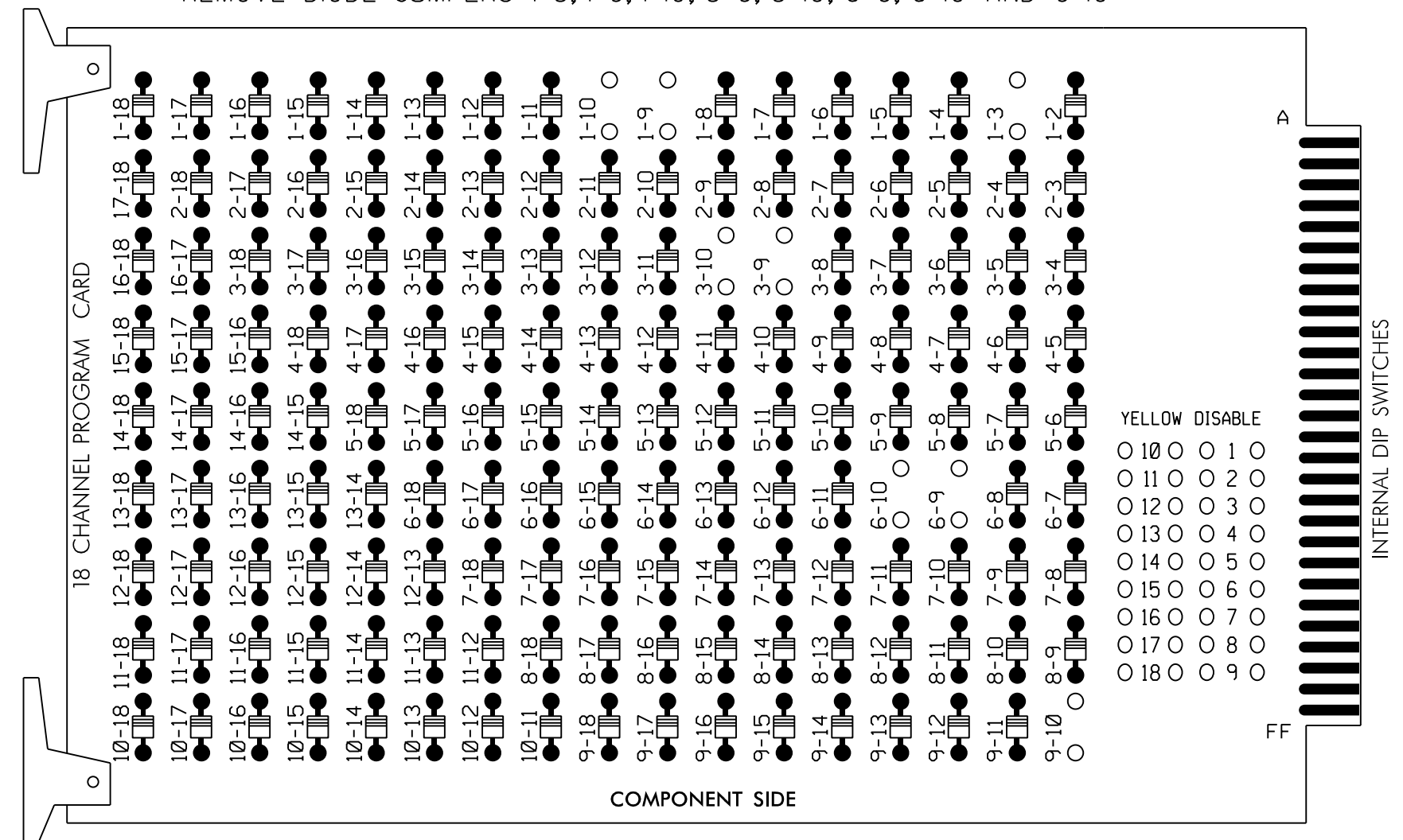

REMOVE JUMPERS AS SHOWN

NOTES:

1. Card is provided with all diode jumpers in place. Removal of any jumper allows its channels to run concurrently.
2. Ensure jumpers SEL2-SEL5 and SEL9 are present on the monitor board.
3. Ensure that Red Enable is active at all times during normal operation.
4. Integrate monitor with Ethernet network in cabinet.

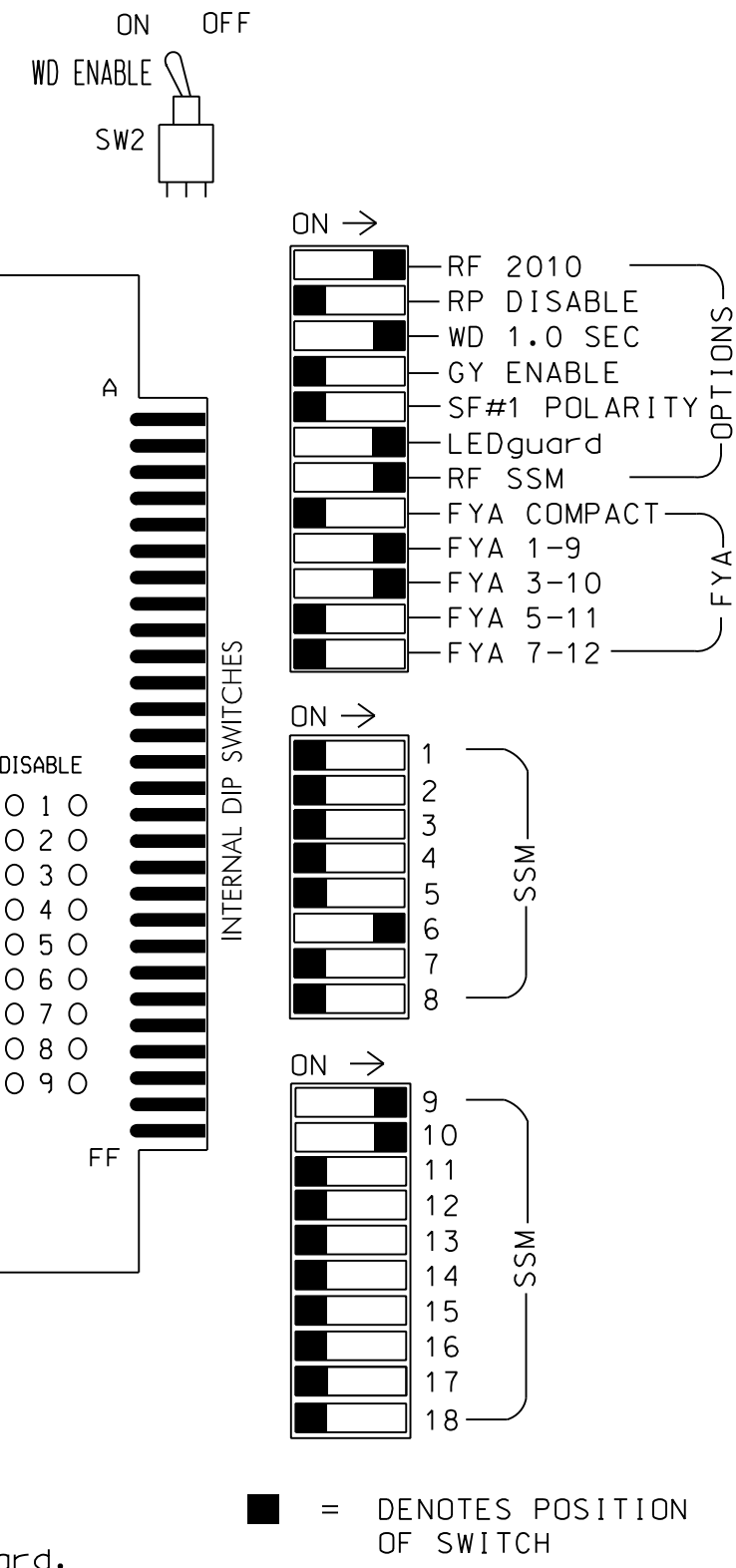

NOTES

1. To prevent "flash-conflict" problems, insert red flash program blocks for all unused vehicle load switches in the output file. The installer shall verify that signal heads flash in accordance with the Signal Plans.
2. Enable Simultaneous Gap-Out for all Phases.
3. Program phase 6 for Variable Initial and Gap Reduction.
4. Program phase 6 for Startup In Green.
5. Program phase 6 for Yellow Flash.
6. The cabinet and controller are part of the Winston-Salem Signal System.

EQUIPMENT INFORMATION

CONTROLLER.....2070
 CABINET.....332 w/ AUX
 SOFTWARE.....ECONOLITE OASIS
 CABINET MOUNT.....BASE
 OUTPUT FILE POSITIONS...18 WITH AUX. OUTPUT FILE
 LOAD SWITCHES USED.....S1,S4,S8,AUX S1,AUX S2
 PHASES USED.....3,6
 OVERLAP "A".....3+6
 OVERLAP "B".....3+6
 OVERLAP "C".....NOT USED
 OVERLAP "D".....NOT USED
 OVERLAP "G".....3

SIGNAL HEAD HOOK-UP CHART

LOAD SWITCH NO.	S1	S2	S3	S4	S5	S6	S7	S8	S9	S10	S11	S12	AUX S1	AUX S2	AUX S3	AUX S4	AUX S5	AUX S6
CMU CHANNEL NO.	1	2	13	3	4	14	5	6	15	7	8	16	9	10	17	11	12	18
PHASE	OLG	2	2 PED	3	4	4 PED	5	6	6 PED	7	8	8 PED	OLA	OLB	SPARE	OLC	OLD	SPARE
SIGNAL HEAD NO.	32	NU	NU	31	NU	NU	NU	61,62	NU	NU	NU	NU	32	31	NU	NU	NU	NU
RED								134										
YELLOW	*			*				135										
GREEN																		
RED ARROW													A121	A124				
YELLOW ARROW													A122	A125				
FLASHING YELLOW ARROW													A123	A126				
GREEN ARROW	127			118				136										

NU = Not Used

* Denotes install load resistor. See load resistor installation detail this sheet.

* See pictorial of head wiring in detail below.

INPUT FILE POSITION LAYOUT

(front view)

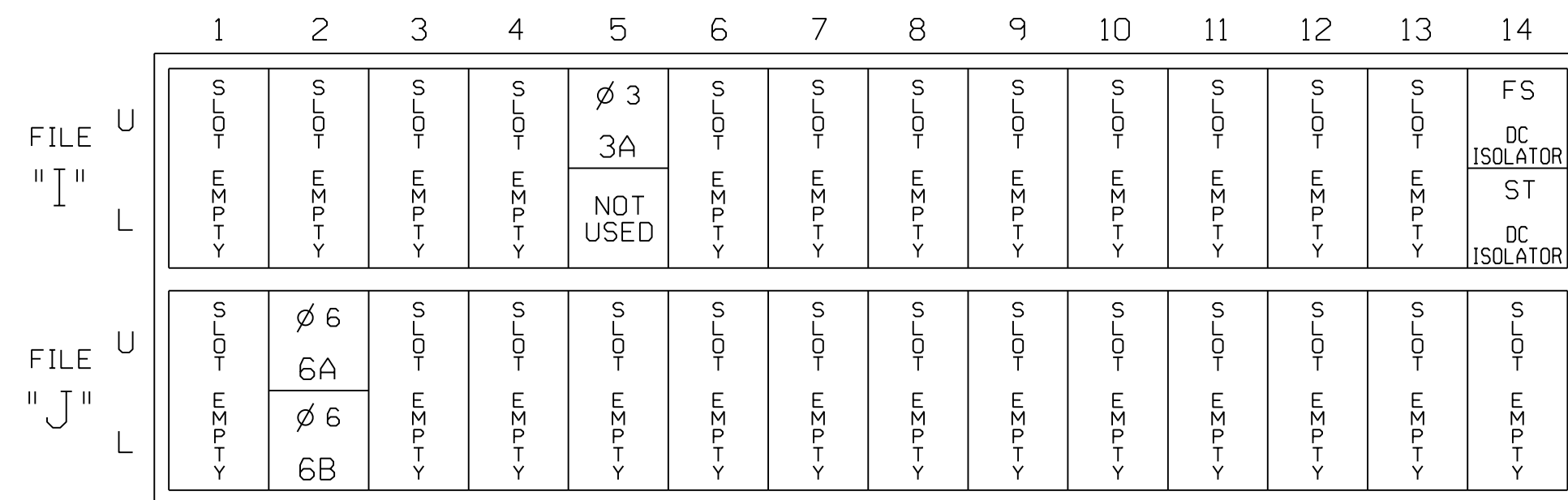

EX.: 1A, 2A, ETC. = LOOP NO.'S

FS = FLASH SENSE
 ST = STOP TIME

INPUT FILE CONNECTION & PROGRAMMING CHART

LOOP NO.	LOOP TERMINAL	INPUT FILE POS.	PIN NO.	INPUT ASSIGNMENT NO.	DETECTOR NO.	NEMA PHASE	CALL	EXTEND	FULL TIME DELAY	STRETCH TIME	DELAY TIME
3A	TB4-5,6	I5U	58	20	3	3	Y	Y			15
6A	TB3-5,6	J2U	40	2	6	6	Y	Y			
6B	TB3-7,8	J2L	44	6	16	6	Y	Y			

* See Input Assignment Programming Details for Alternate Phasing on sheet 4.

INPUT FILE POSITION LEGEND: J2L

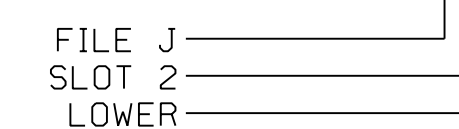

FYA SIGNAL WIRING DETAIL

(wire signal heads as shown)

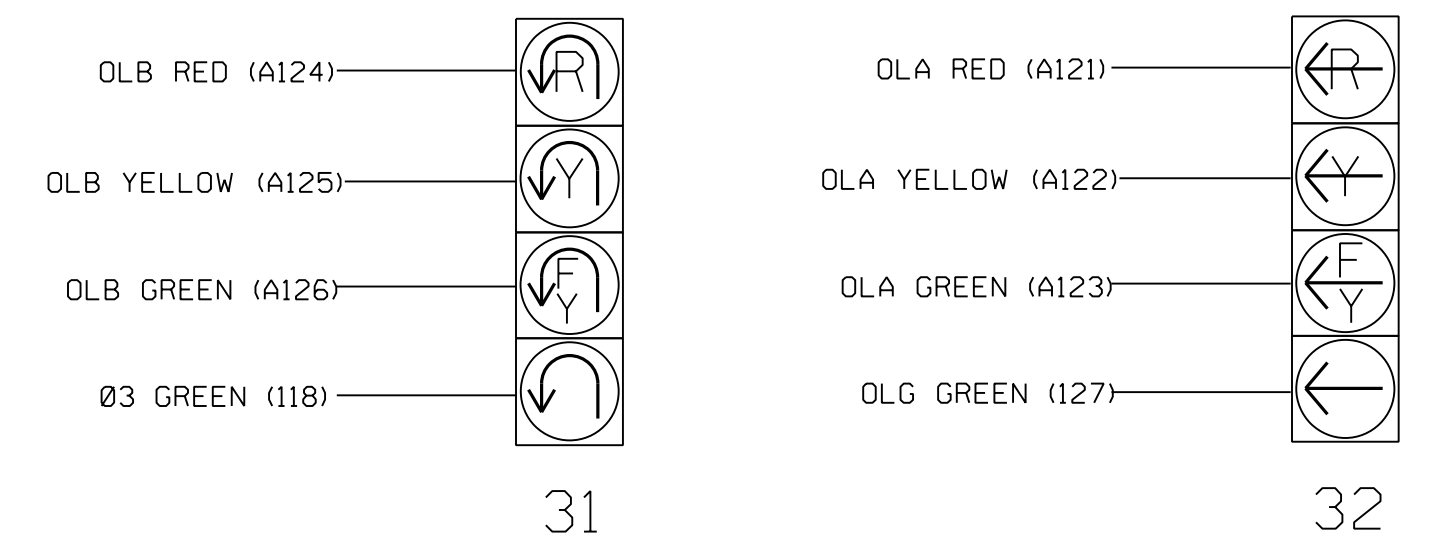

NOTE

The sequence display for these signals require special logic programming. See sheet 2 for programming instructions.

LOAD RESISTOR INSTALLATION DETAIL

VALUE (ohms)	WATTAGE
1.5K - 1.9K	25W (min)
2.0K - 3.0K	10W (min)

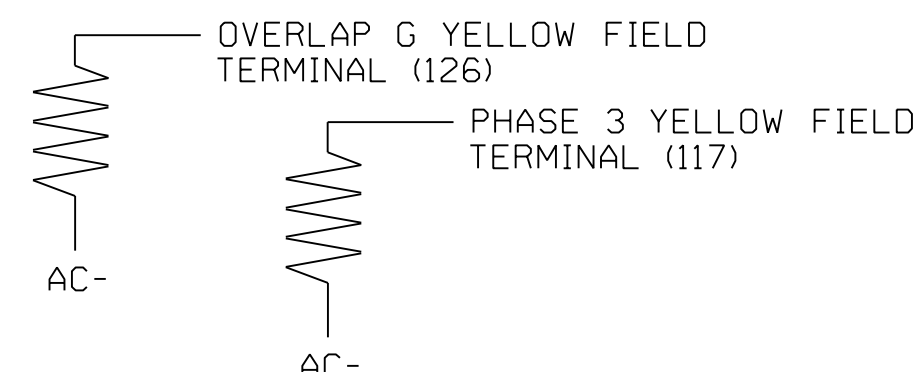

THIS ELECTRICAL DETAIL IS FOR THE SIGNAL DESIGN: 09-0982
 DESIGNED: February 2024
 SEALED: February 12, 2024
 REVISED:

RK&K
 P: (919) 878-8560
 8801 Six Forks Road Suite 700 | Raleigh, North Carolina 27615-2965
 NC License No. F-0112
 www.rk.com
 Engineers | Construction Managers | Planners | Scientists
 Responsive People | Creative Solutions

Signal Upgrade - Final Design
 Electrical Detail - Sheet 1 of 5

US 158 WB (Reidsville Rd.)
 at
 U-Turn East of
 SR 2662 (Old Greensboro Rd.)

Division 9 Forsyth County Winston-Salem
 PLAN DATE: February 2024 REVIEWED BY: DT Sears
 PREPARED BY: WP Erickson-Jones REVIEWED BY:

REVISIONS: INIT. DATE

DocuSign by
 Porter Jones
 2/12/2024
 SIGNATURE DATE
 SIG. INVENTORY NO. 09-0982

DOCUMENT NOT CONSIDERED FINAL UNLESS ALL SIGNATURES COMPLETED

SEAL
 NORTH CAROLINA PROFESSIONAL ENGINEER
 SEAL 056142
 W. PORTER JONES