

PROJECT REFERENCE NO. R-2577A	SHEET NO. PMP-18
APPROVED: <i>David T. Sears</i> 089183F28E5741E..	
DATE: 3/7/2024	
SEAL	
	
DOCUMENT NOT CONSIDERED FINAL UNLESS ALL SIGNATURES COMPLETED	

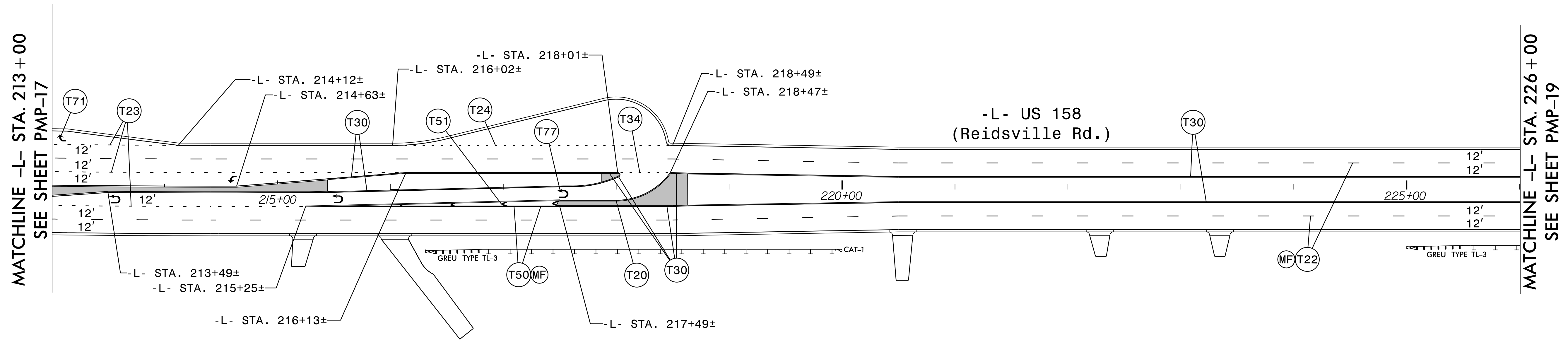
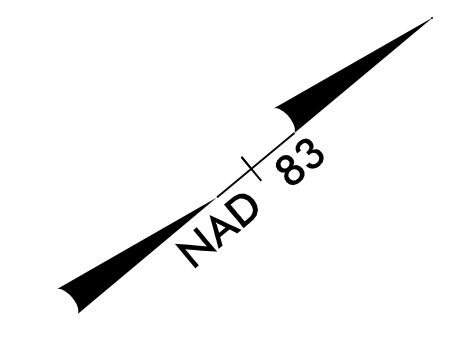

R:\2024\2577A_PMP-18.dgn

RKK
 P: (919) 878-9550
 6601 Six Forks Road, Forum 1, Suite 700
 Raleigh, North Carolina 27615-3960
 NC License No. F-0112

Engineers | Construction Managers | Planners | Scientists
www.rkk.com
 Responsive People | Creative Solutions

PAVEMENT MARKING DETAIL