

BAGGED STONE AND PIPE SHALL BE PLACED IMMEDIATELY AFTER COMPLETION OF END BENT EXCAVATION. PIPE MAY BE EITHER CONCRETE, CORRUGATED STEEL, CORRUGATED ALUMINUM ALLOY, OR CORRUGATED PLASTIC. PERFORATED PIPE WILL NOT BE ALLOWED.

BAGGED STONE SHALL REMAIN IN PLACE UNTIL THE ENGINEER DIRECTS THAT IT BE REMOVED. THE CONTRACTOR SHALL REMOVE AND DISPOSE OF SILT ACCUMULATIONS AT BAGGED STONE WHEN SO DIRECTED BY THE ENGINEER. BAGS SHALL BE REMOVED AND REPLACED WHENEVER THE ENGINEER DETERMINES THAT THEY HAVE DETERIORATED AND LOST THEIR EFFECTIVENESS.

NO SEPARATE PAYMENT WILL BE MADE FOR THIS WORK AND THE ENTIRE COST OF THIS WORK SHALL BE INCLUDED IN THE UNIT CONTRACT PRICE BID FOR THE SEVERAL PAY ITEMS.

TEMPORARY DRAINAGE AT END BENT

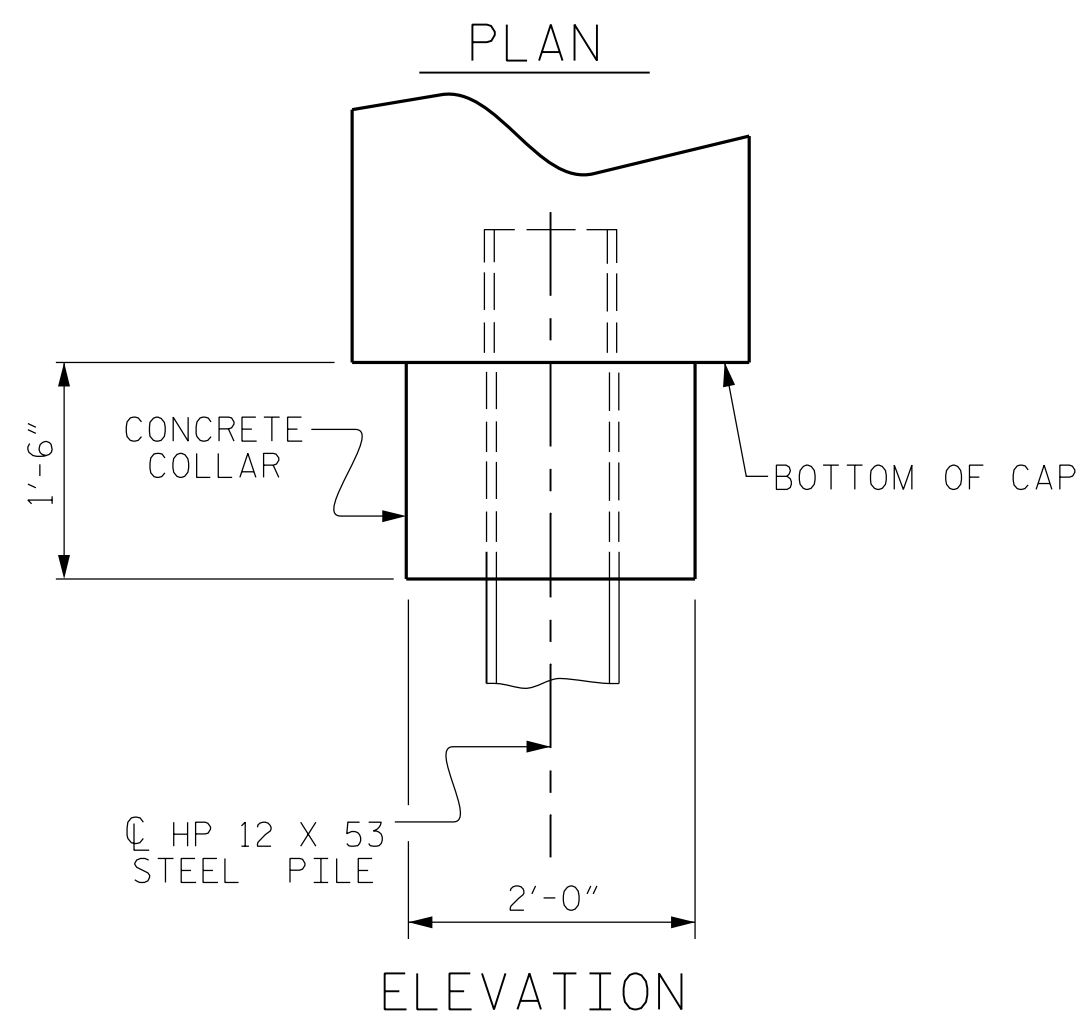
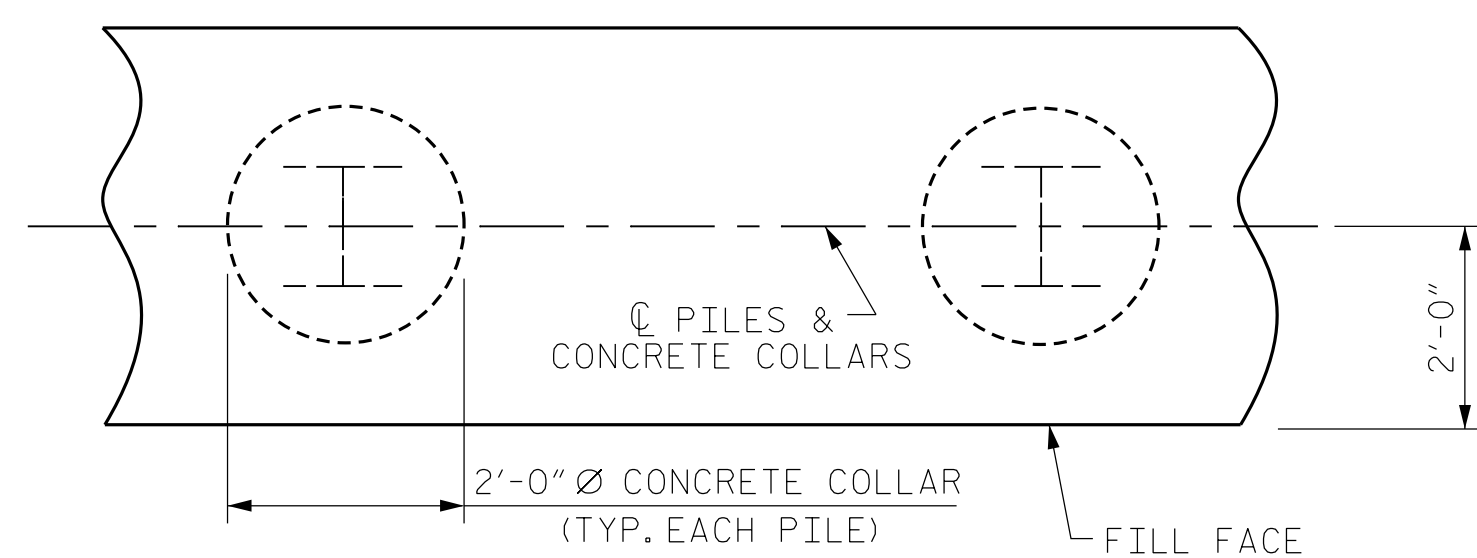

CORROSION PROTECTION FOR STEEL PILES DETAIL

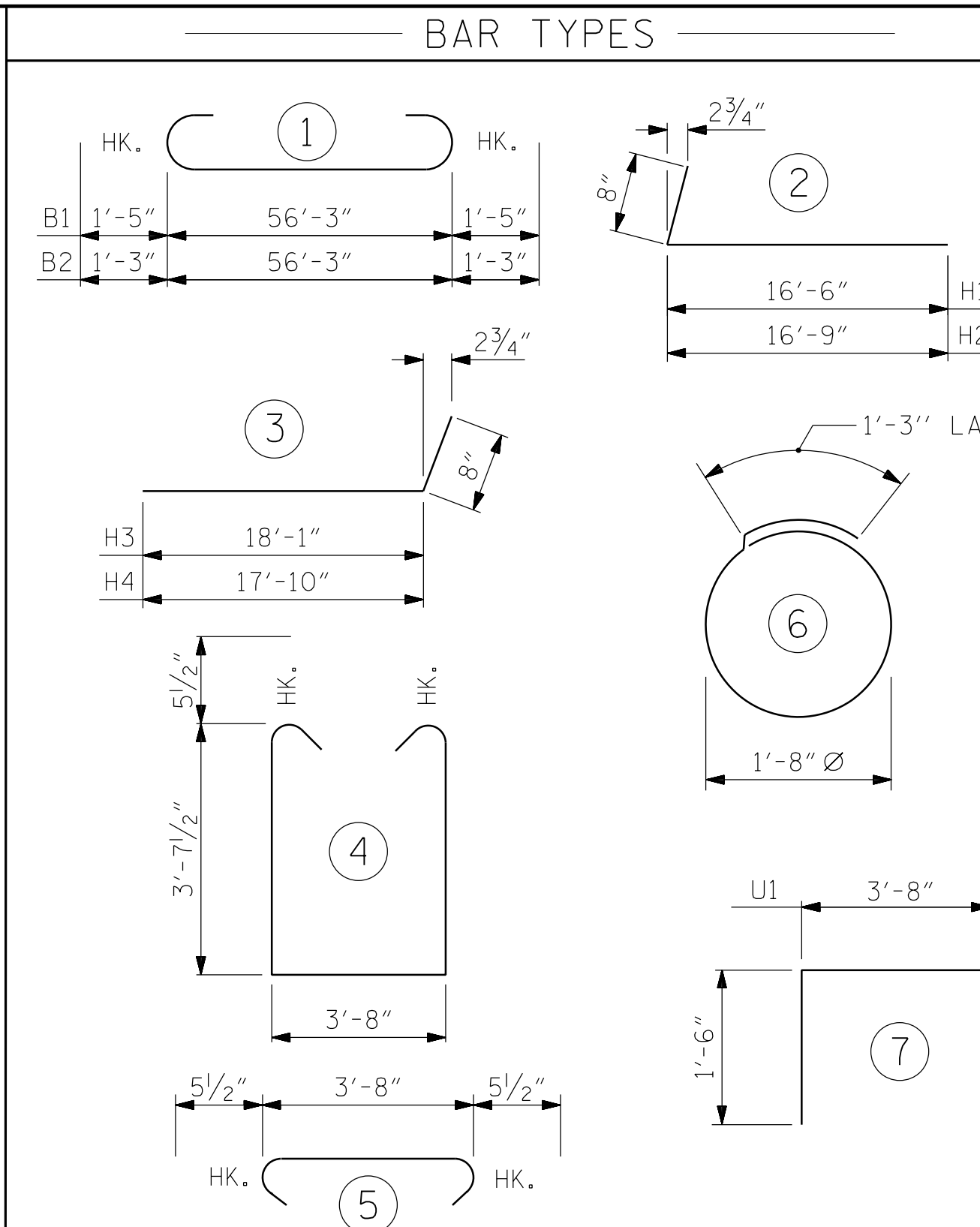

ALL BAR DIMENSIONS ARE OUT TO OUT.

BILL OF MATERIAL FOR END BENT #1					
BAR NO.	NO.	SIZE	TYPE	LENGTH	WEIGHT
B1	4	#10	1	59'-1"	1,017
B2	5	#9	1	58'-9"	999
B3	8	#5	STR	56'-5"	471
B4	8	#4	STR	29'-5"	157
B5	14	#4	STR	3'-8"	34
B6	5	#4	STR	9'-10"	33
B7	5	#4	STR	31'-10"	106
H1	8	#6	2	17'-2"	206
H2	8	#6	2	17'-5"	209
H3	9	#6	3	18'-9"	253
H4	9	#6	3	18'-6"	250
S1	68	#5	4	11'-10"	839
S2	68	#5	5	4'-7"	325
S3	36	#4	6	6'-6"	156
U1	29	#4	7	6'-8"	129
V1	88	#5	STR	6'-7"	604
V2	31	#5	STR	6'-2"	199
V3	33	#5	STR	6'-9"	232
REINFORCING STEEL (FOR END BENT #1)					6,219 LBS.
CLASS A CONCRETE BREAKDOWN (FOR END BENT #1)					
POUR #1 CAP, COLLARS & LOWER PART OF WINGS					42.4 C.Y.
TOTAL CLASS A CONCRETE					42.4 C.Y.
HP 12 X 53 STEEL PILES					NO: 9
					LIN. FT. = 210
PILE DRIVING EQUIPMENT SETUP FOR HP 12 X 53 STEEL PILES					NO: 9
STEEL PILE POINTS					NO: 9

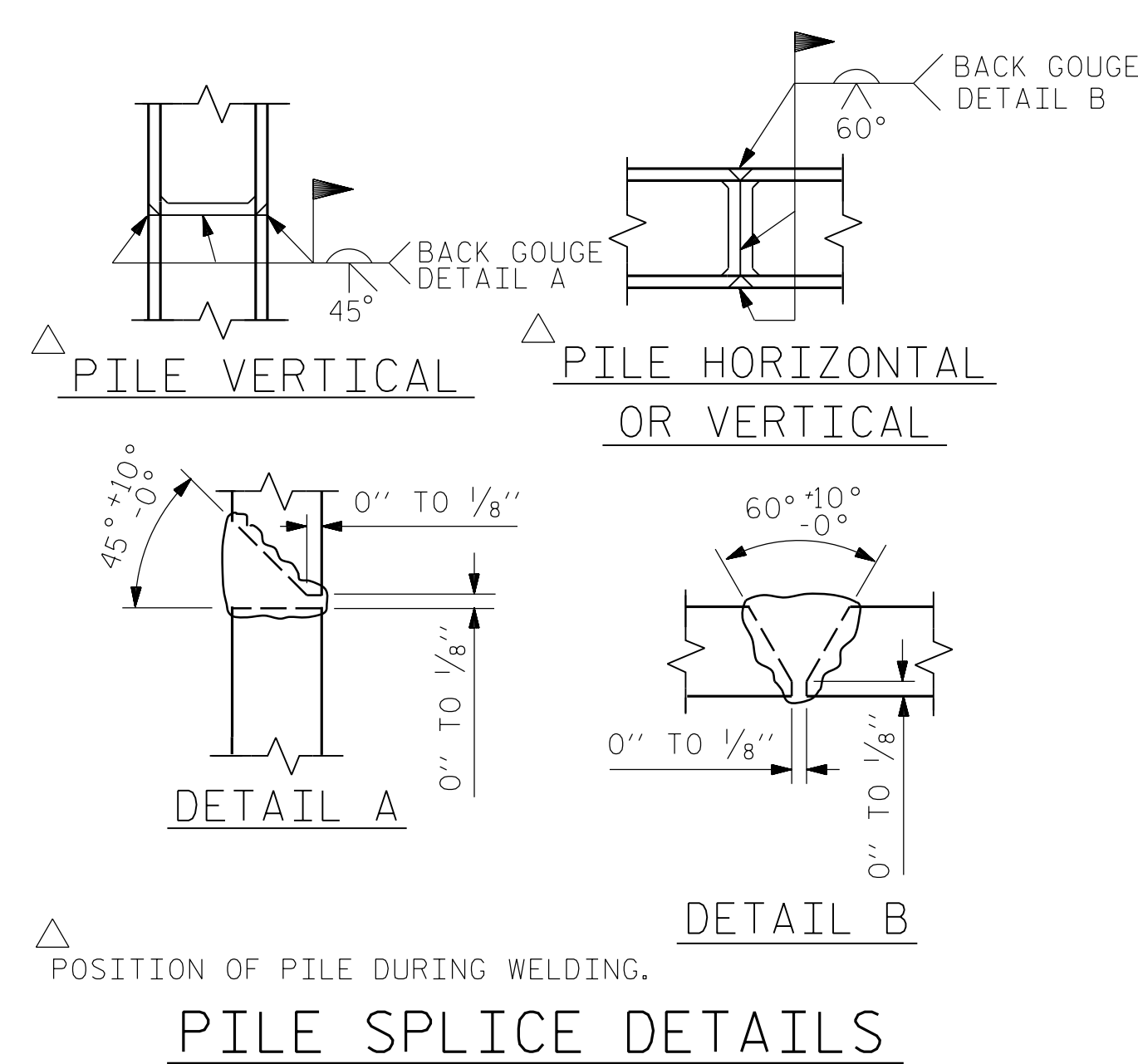
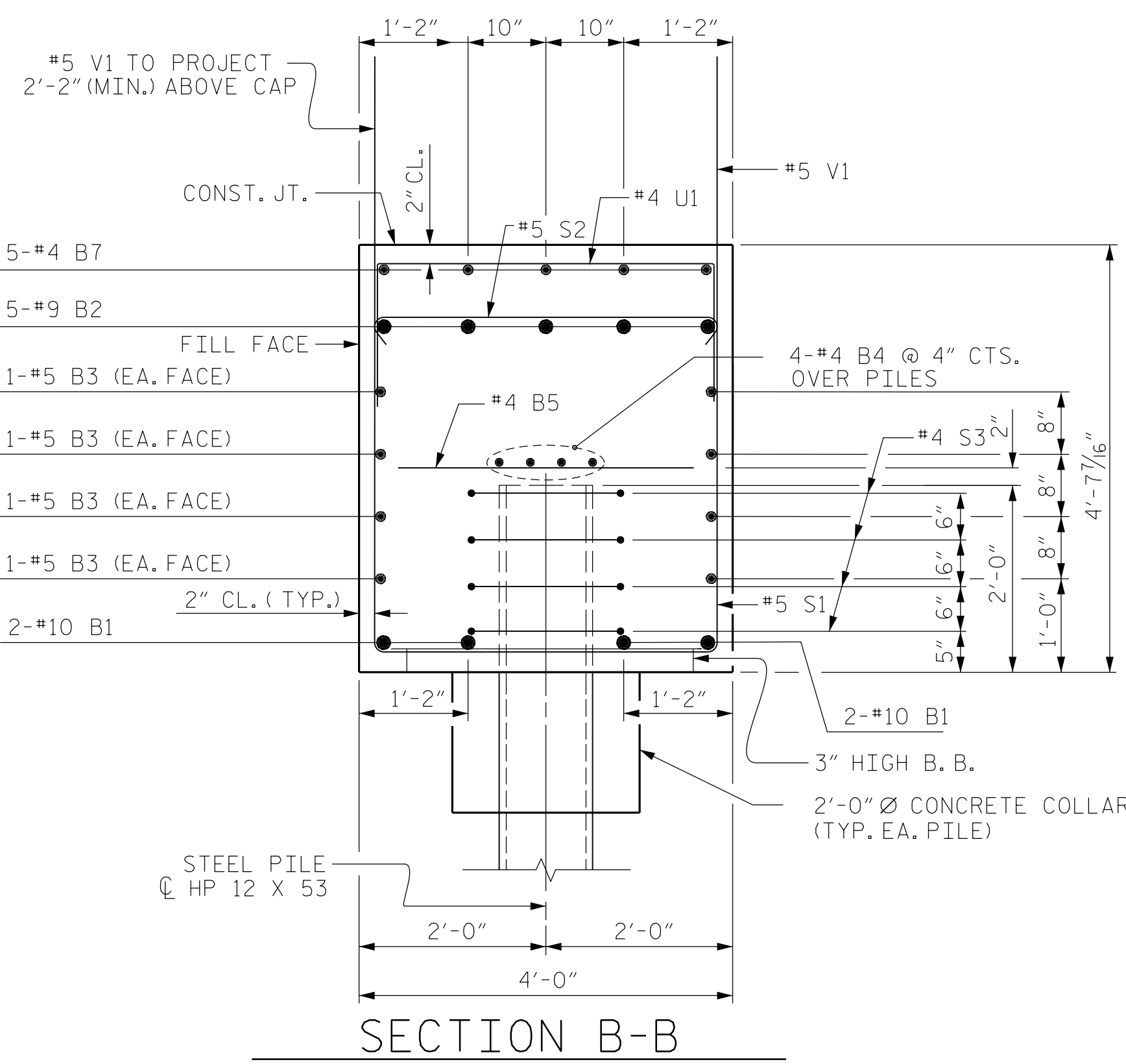
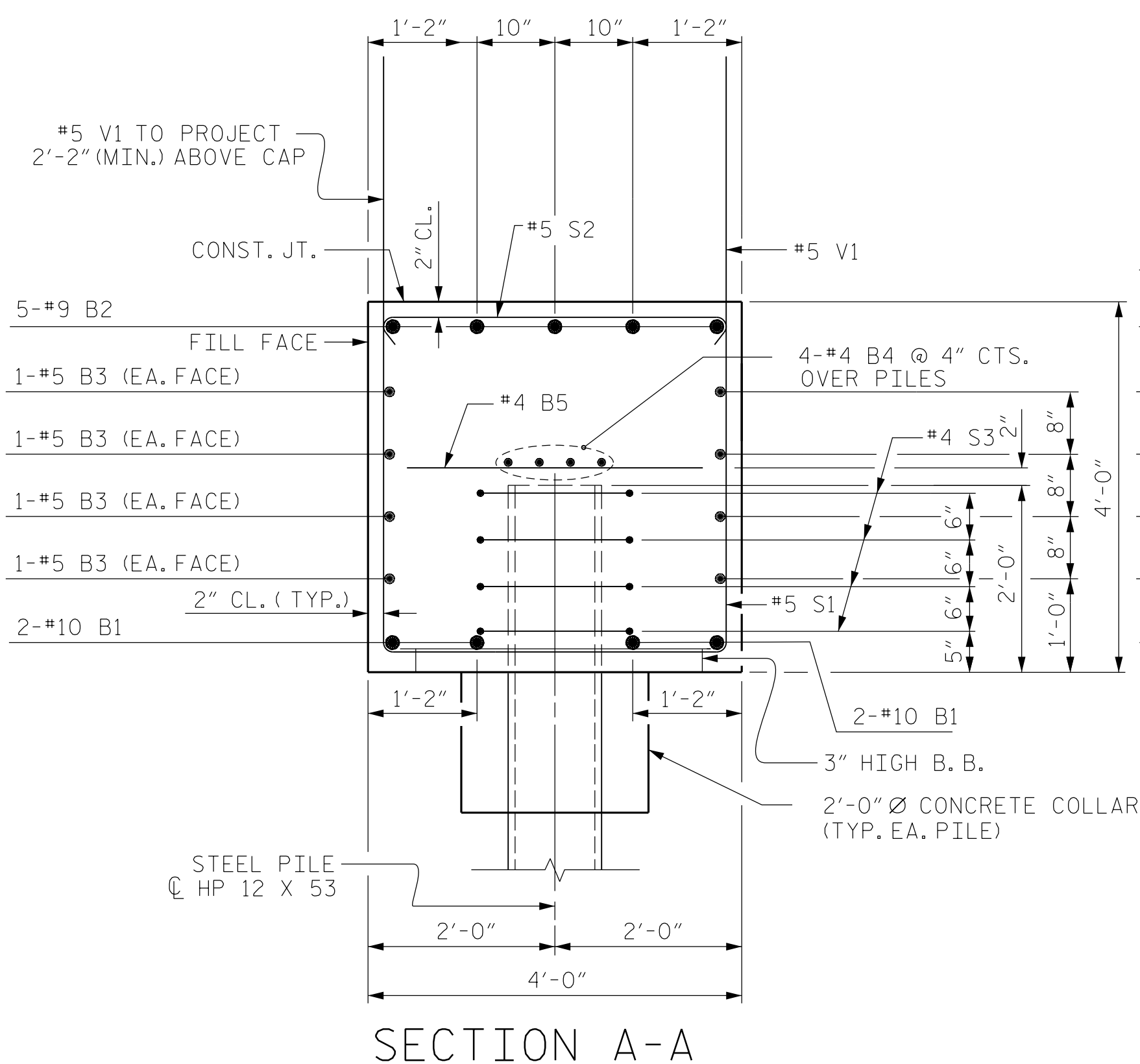

PROJECT NO. BR-0069

CASWELL COUNTY

STATION: 20+18.00 -L-

SHEET 3 OF 3

STATE OF NORTH CAROLINA
DEPARTMENT OF TRANSPORTATION
RALEIGH
SUBSTRUCTURE
INTEGRAL END BENT 1
DETAILS

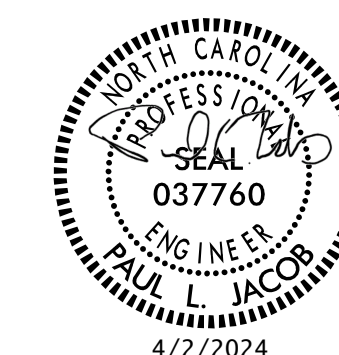

DRAWN BY : J. WEIGER DATE : 6-2023

CHECKED BY : J. LOFTUS DATE : 8-2023

DESIGN ENGINEER OF RECORD : J. LOFTUS DATE : 3-2024

moftatt & nichol
4700 FALLS OF NEUSE ROAD, SUITE 300
RALEIGH, NORTH CAROLINA 27609
(919) 781-4626 VOICE (919) 781-4869 FAX
NC License NO.: F-0105

DOCUMENT NOT CONSIDERED FINAL UNLESS ALL SIGNATURES COMPLETED

REVISIONS						SHEET NO.
NO.	BY:	DATE:	NO.	BY:	DATE:	
1			3			S-27
2			4			TOTAL SHEETS 38