

NOTES:

#5 S1 AND S2 BARS MAY BE SHIFTED SLIGHTLY TO MAINTAIN 2" CLEAR TO EXPANSION JOINT IN RAIL.

DIMENSIONS ARE MEASURED ALONG OUTSIDE EDGE OF BARRIER RAIL.

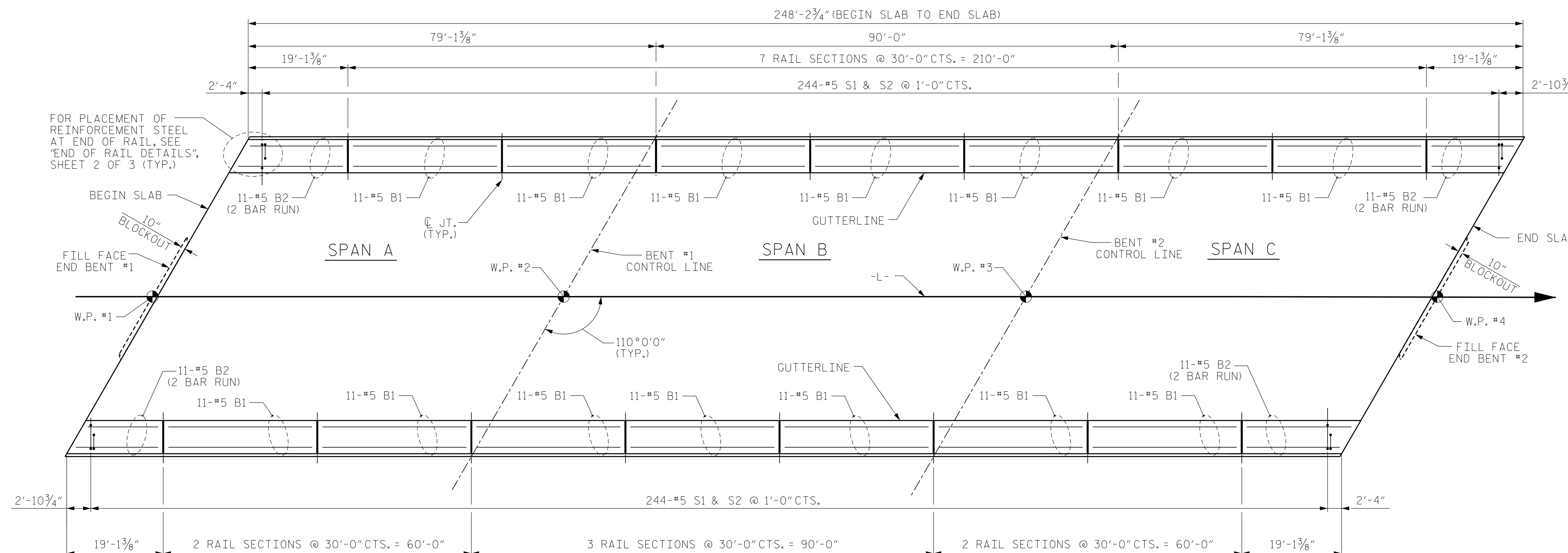

PLAN OF CONCRETE BARRIER RAIL

PROJECT NO. BR-0069

CASWELL COUNTY

STATION: 20+18.00 -L-

SHEET 1 OF 3

STATE OF NORTH CAROLINA
DEPARTMENT OF TRANSPORTATION
RALEIGH

CONCRETE BARRIER
RAIL PLAN

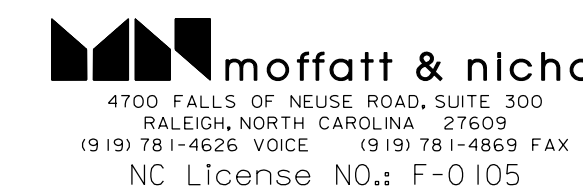
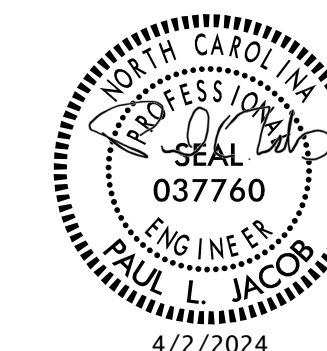

DOCUMENT NOT CONSIDERED
FINAL UNLESS ALL
SIGNATURES COMPLETED

DRAWN BY : J. WEIGER DATE : 1-2023
CHECKED BY : J. LOFTUS DATE : 8-2023
DESIGN ENGINEER OF RECORD: J. LOFTUS DATE : 3-2024

| REVISIONS | | | | | | SHEET NO. |
|-----------|-----|-------|-----|-----|-------|--------------|
| NO. | BY: | DATE: | NO. | BY: | DATE: | S-21 |
| 1 | | | 3 | | | TOTAL SHEETS |
| 2 | | | 4 | | | 38 |

3/20/2024 02:18:10 PM \\109\BRO-0069\Structures\01-CADD\02-FinalDrawings\01_041_BRO069_SML_BRO1_021_160001.dgn jloftus