

**NOTES**

PROVIDE 1/4" HIGH BEAM BOLSTERS UPPER AT 4'-0" CTS. ATOP THE METAL STAY-IN-PLACE FORMS TO SUPPORT THE BOTTOM MAT OF "A" BARS WHEN USING REMOVABLE FORMS. PROVIDE CONTINUOUS HIGH CHAIRS FOR METAL DECK (C.H.C.M.) @ 4'-0" CTS. WITH A HEIGHT TO SUPPORT THE BOTTOM MAT OF "A" BARS A CLEAR DISTANCE OF 2/2" ABOVE THE TOP OF THE REMOVABLE FORM.

LONGITUDINAL STEEL MAY BE SHIFTED SLIGHTLY, AS NECESSARY TO AVOID INTERFERENCE WITH STIRRUPS IN PRESTRESSED CONCRETE GIRDERS.

PREVIOUSLY CAST CONCRETE IN A CONTINUOUS UNIT SHALL HAVE ATTAINED A MINIMUM COMPRESSIVE STRENGTH OF 3,000 PSI. BEFORE ADDITIONAL CONCRETE IS CAST IN THE UNIT.

BARRIER RAIL IN A CONTINUOUS UNIT SHALL NOT BE CAST UNTIL ALL SLAB CONCRETE IN THE UNIT HAS BEEN CAST AND HAS REACHED A MINIMUM COMPRESSIVE STRENGTH OF 3,000 PSI.

NO WELDING OF FORMS OR FALSEWORK TO THE TOP OF THE GIRDER WILL BE PERMITTED IN THE LINK SLAB AREA. SEE "PLAN OF SPANS" SHEETS FOR LOCATIONS.

FOR INTERMEDIATE STEEL DIAPHRAGM DETAILS, SEE "INTERMEDIATE STEEL DIAPHRAGMS FOR TYPE IV PRESTRESSED CONCRETE GIRDERS" SHEET.

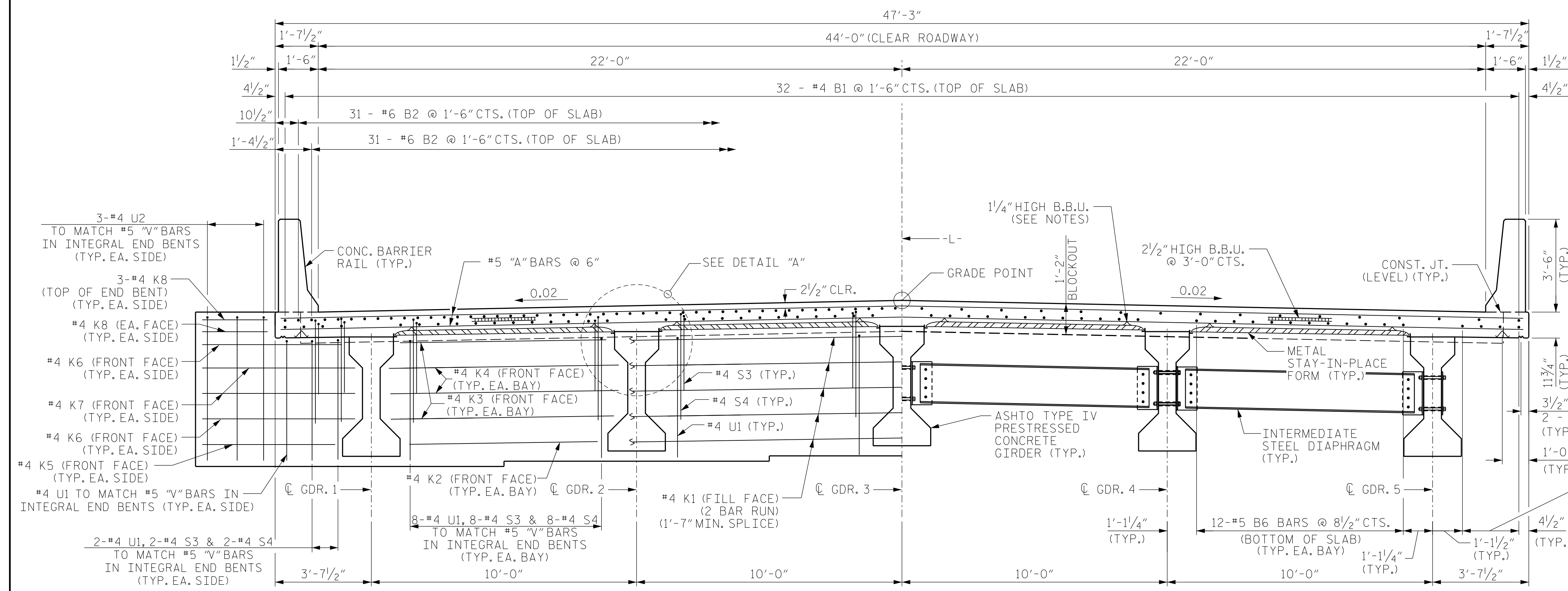

HALF SECTION AT INTEGRAL END BENT DIAPHRAGM      HALF SECTION AT INTERMEDIATE DIAPHRAGM  
**TYPICAL SECTION**

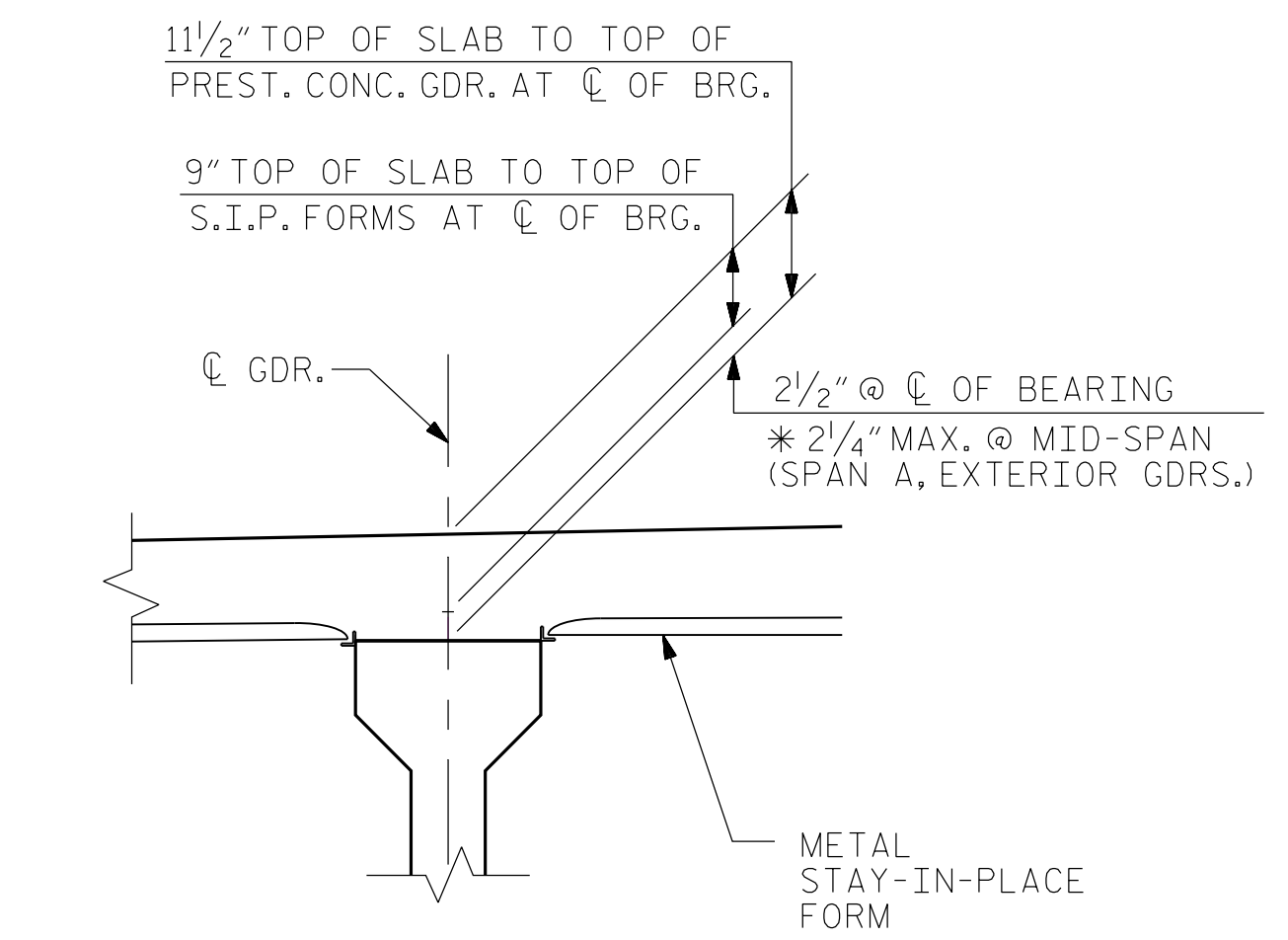

**DETAIL "A"**  
\* BASED ON PREDICTED FINAL CAMBER AND THEORETICAL GRADE LINE ELEVATIONS

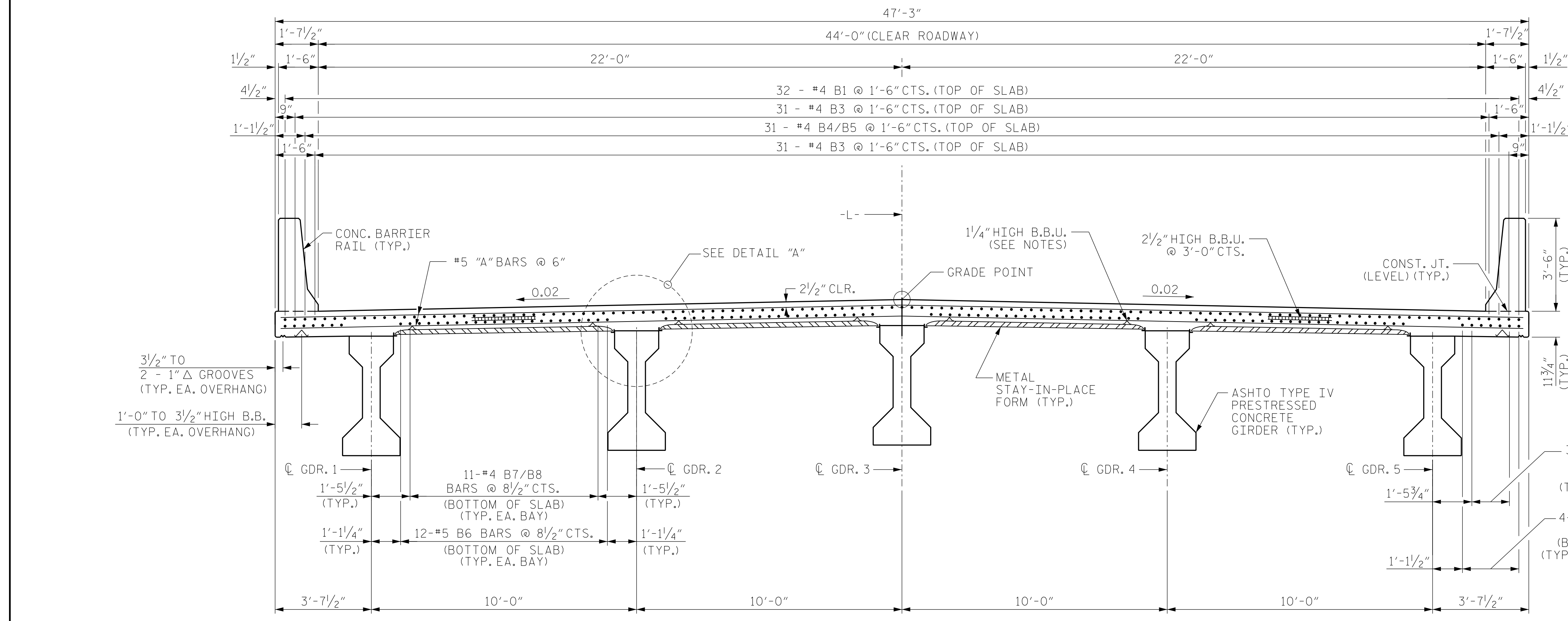

**TYPICAL SECTION THROUGH LINK SLAB**

PROJECT NO. BR-0069  
CASWELL COUNTY  
 STATION: 20+18.00 -L-  
 SHEET 1 OF 2

STATE OF NORTH CAROLINA  
 DEPARTMENT OF TRANSPORTATION  
 RALEIGH

**TYPICAL SECTION**

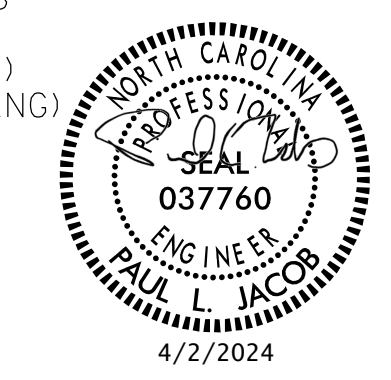

DRAWN BY : J. WEIGER      DATE : 5-2023  
 CHECKED BY : J. LOFTUS      DATE : 8-2023  
 DESIGN ENGINEER OF RECORD : J. LOFTUS      DATE : 3-2024

**moffatt & nichol**  
 4700 FALLS OF NEUSE ROAD, SUITE 300  
 RALEIGH, NORTH CAROLINA 27609  
 (919) 781-4626 VOICE    (919) 781-4869 FAX  
 NC License No.: F-0105

DOCUMENT NOT CONSIDERED  
 FINAL UNLESS ALL  
 SIGNATURES COMPLETED

REVISIONS						SHEET NO.
NO.	BY:	DATE:	NO.	BY:	DATE:	TOTAL SHEETS
1			3			38
2			4			

3/20/2024 02:14:01 101-109\BR-0069\Structures\01-CADD\02-FinalDrawings\01-011-BR0069\_SMLL\_T501\_006\_160001.dgn  
 JLF