

|   |           |
|---|-----------|
| PROJ. REFERENCE NO.   | SHEET NO. |
| U-6036  | TMP-9     |
|  TGS ENGINEERS<br>201 W. MARION ST. STE 200<br>SHELBY, NC 28150<br>PH: (704) 474-0003<br>CORP. LICENSE NO.: C-0275 |           |

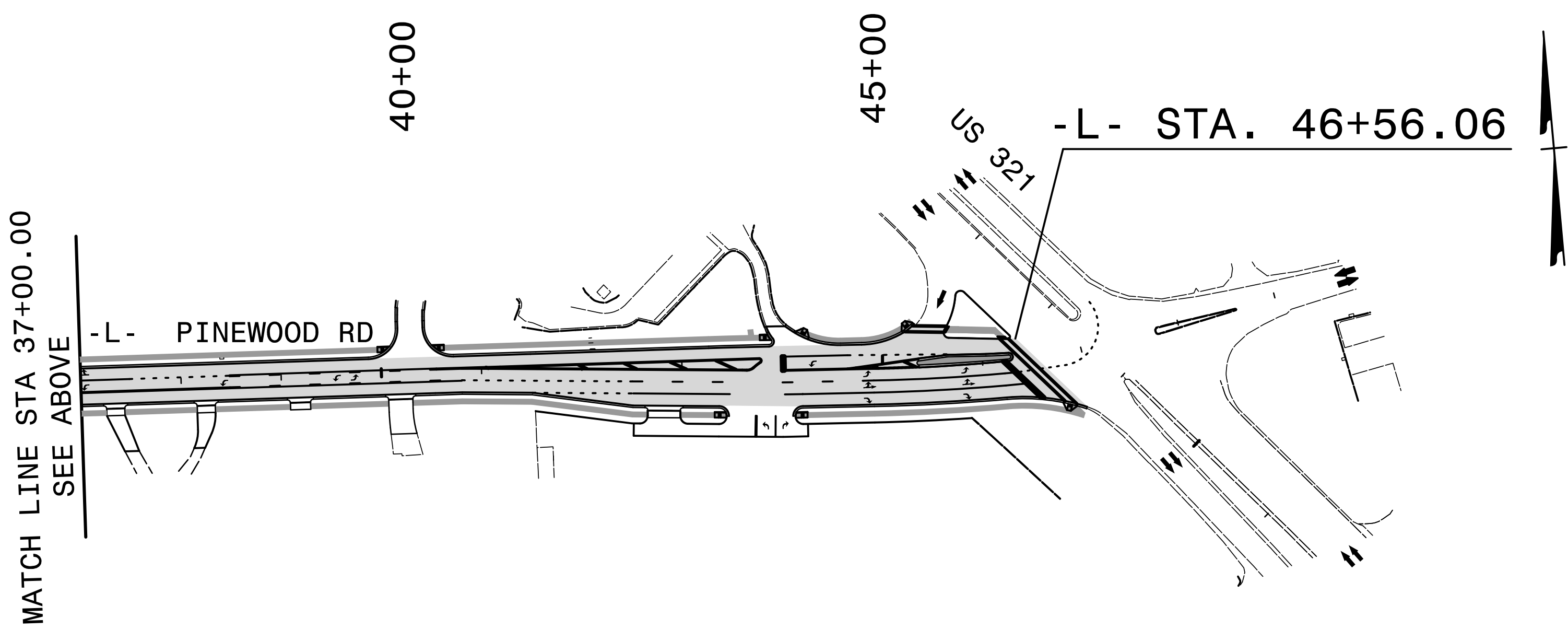
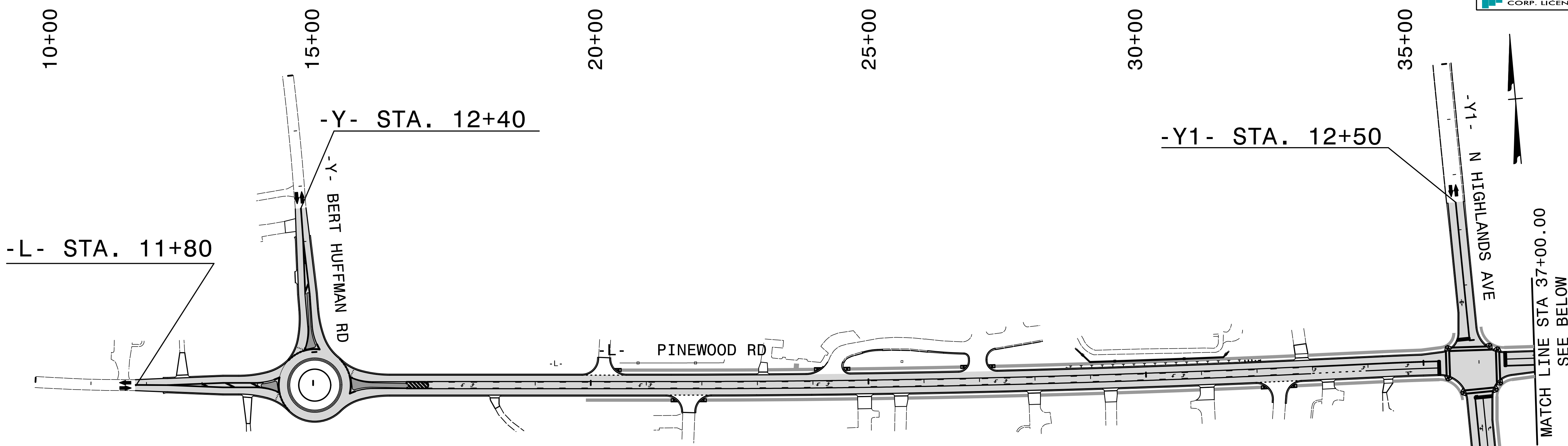
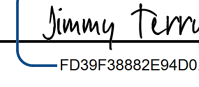

SEE PAVEMENT MARKING PLANS FOR FINAL PAVEMENT MARKING SCHEDULE AND LAYOUT.

APPROVED:   
DocuSigned by: Jimmy Terry  
FD39F3882E84D0

DATE: 1/11/2024

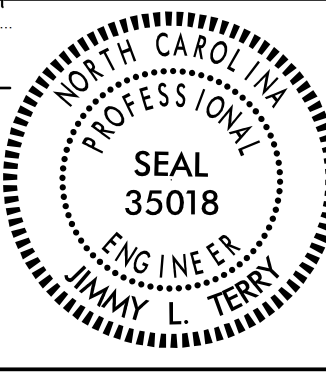
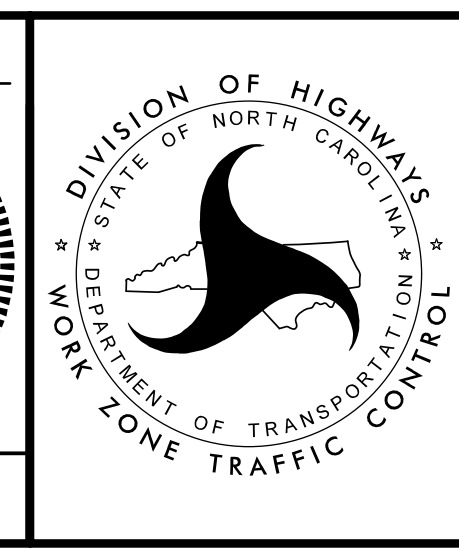
**PHASE II**

DOCUMENT NOT CONSIDERED FINAL  
UNLESS ALL SIGNATURES COMPLETED

1/11/2024  
 X:\NC024\U-6036\Traffic\TrafficControl\TCP\U-6036\_TC\_TMP\_09\PH2\_0V.dgn  
 User: jsmelvin