

PROJECT REFERENCE NO.	SHEET NO.
U-5112	UC-3A
DESIGNED BY: SJJ	
DRAWN BY: SCA	
CHECKED BY: MAS	
APPROVED BY:	
REVISED:	
NORTH CAROLINA DEPARTMENT OF TRANSPORTATION UTILITIES ENGINEERING SECTION PHONE: (919) 707-6690 FAX: (919) 250-4151	
UTILITY CONSTRUCTION PLANS ONLY	

UTILITY CONSTRUCTION

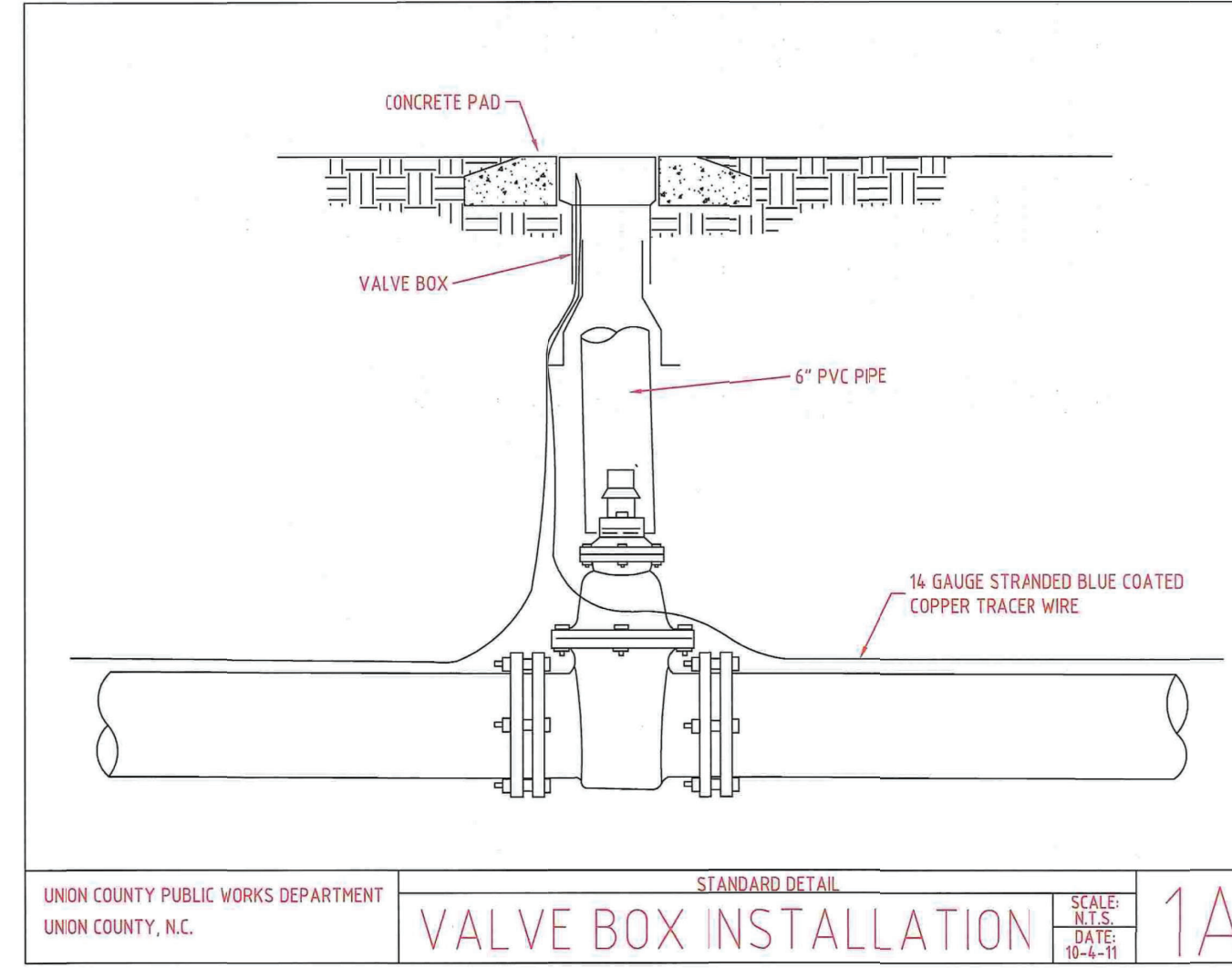

NOTE: FOR PIPE DEPTH GREATER THAN 5-FOOT, PROVIDE SWIVEL JOINT VALVE EXTENSION.

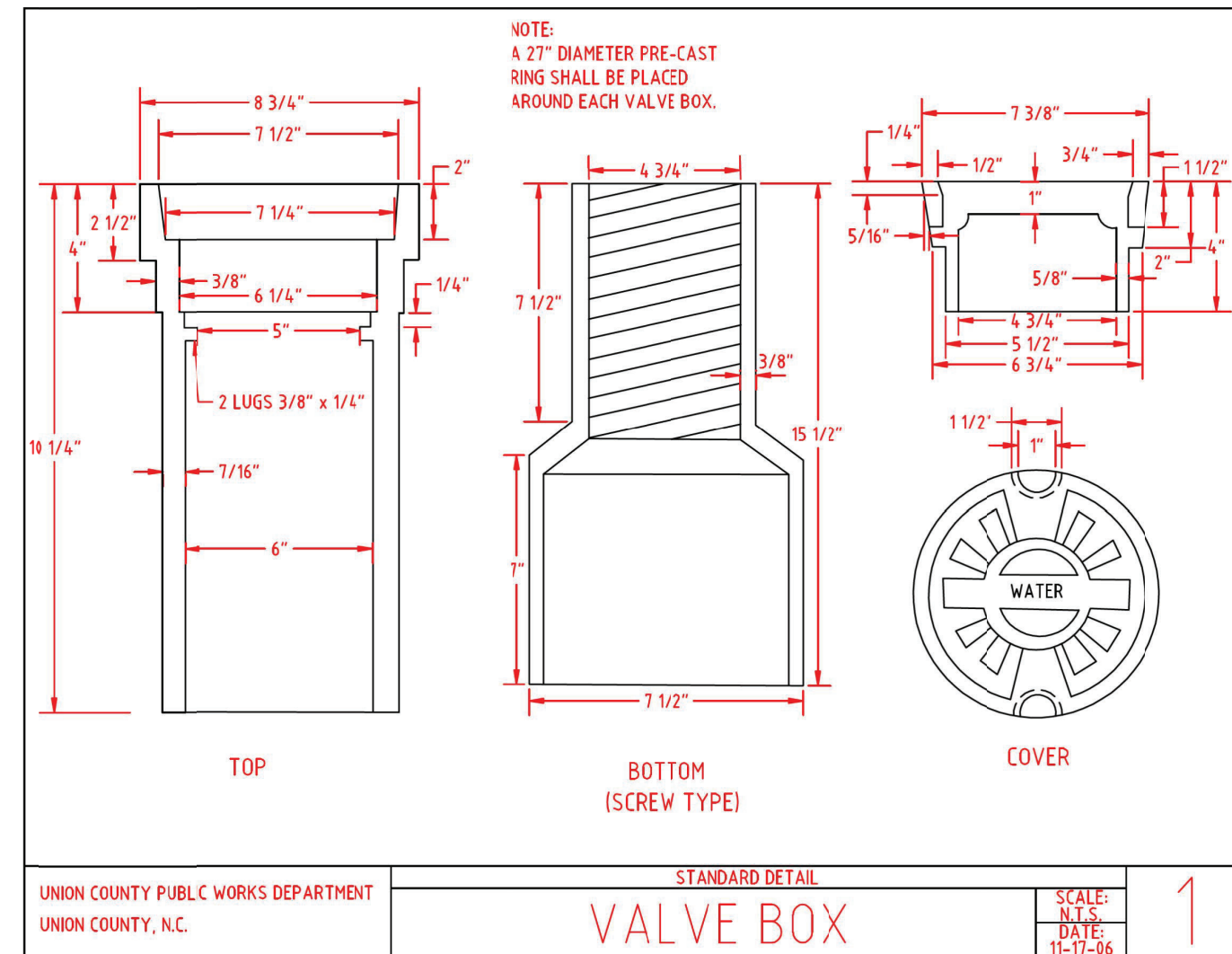
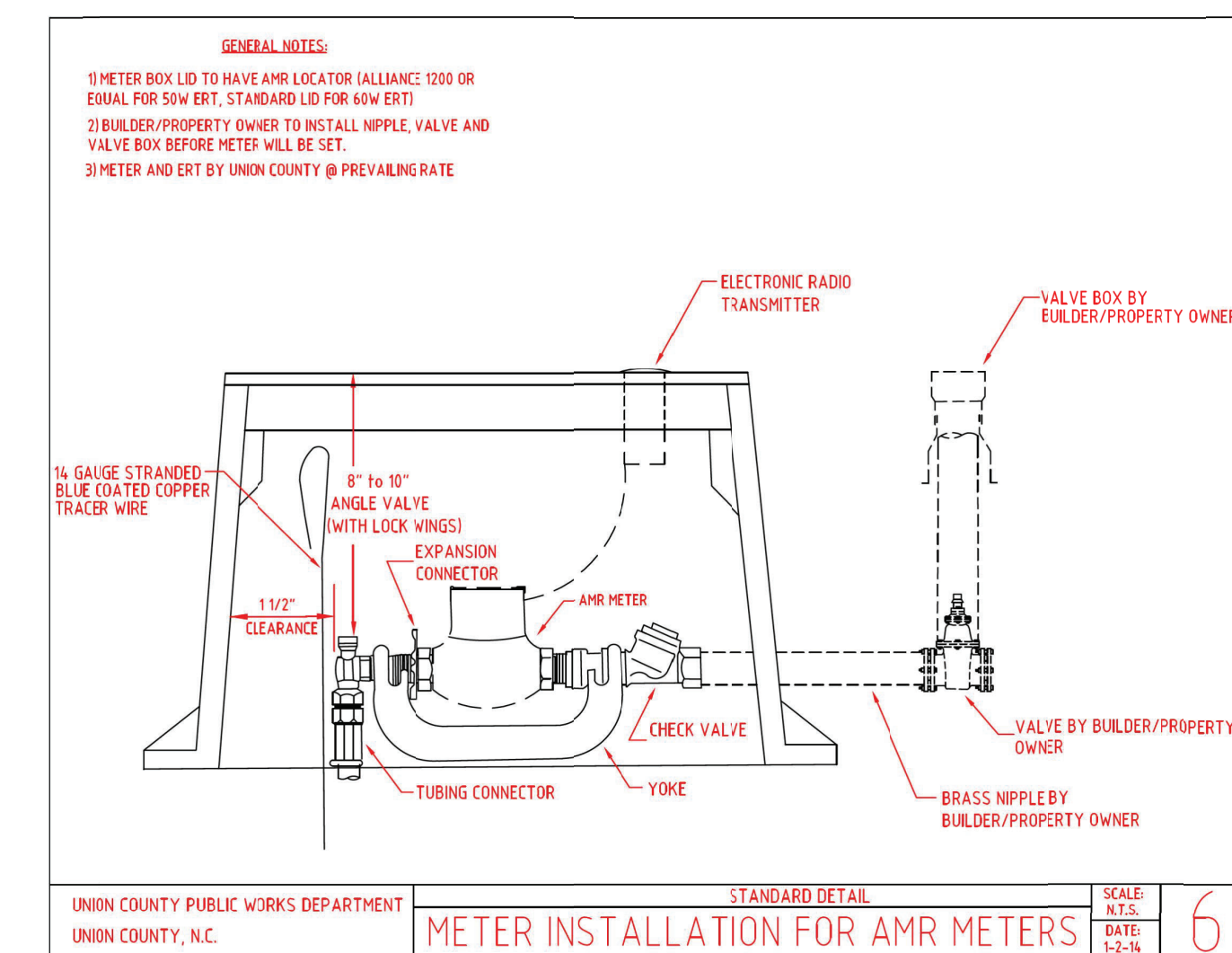
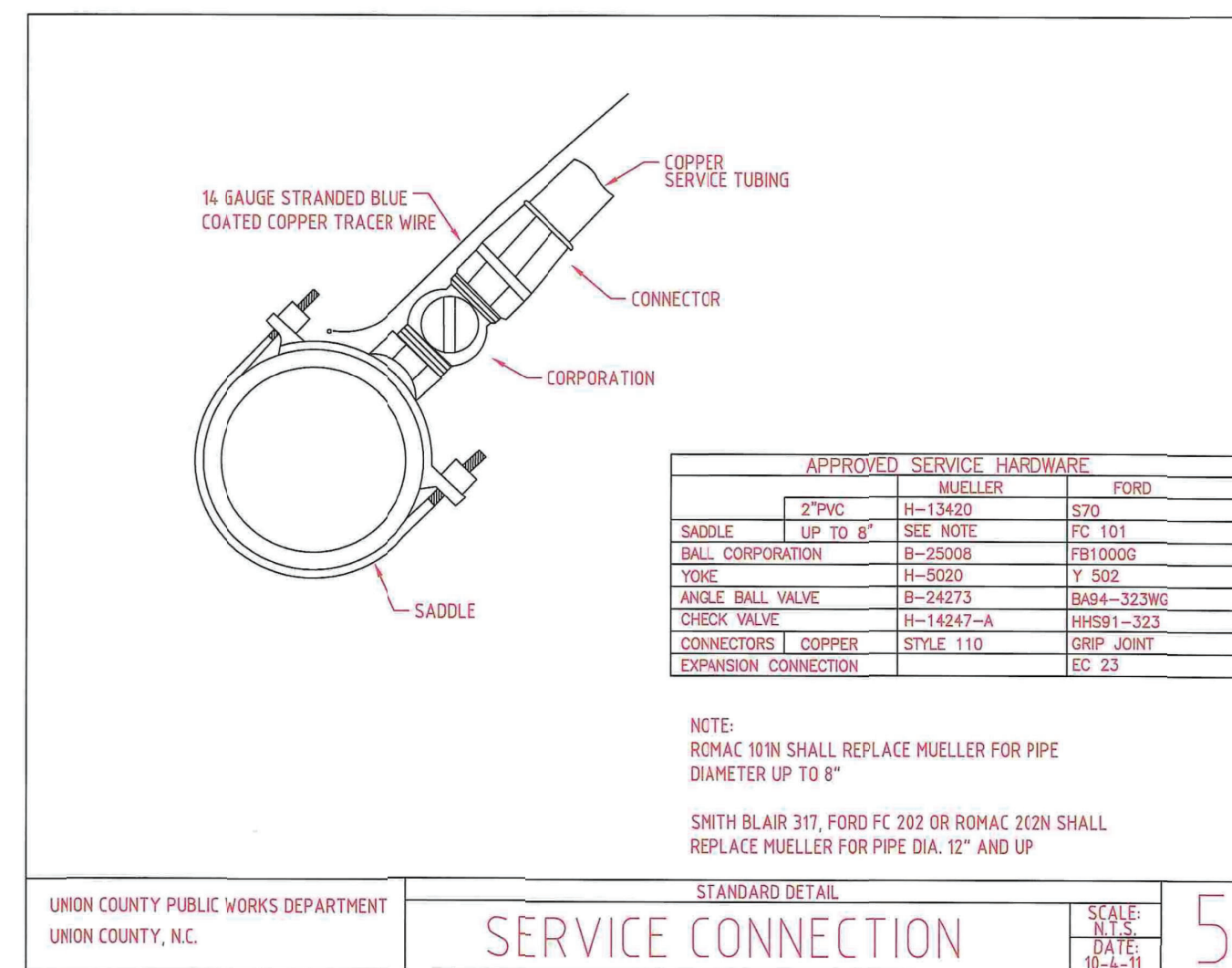
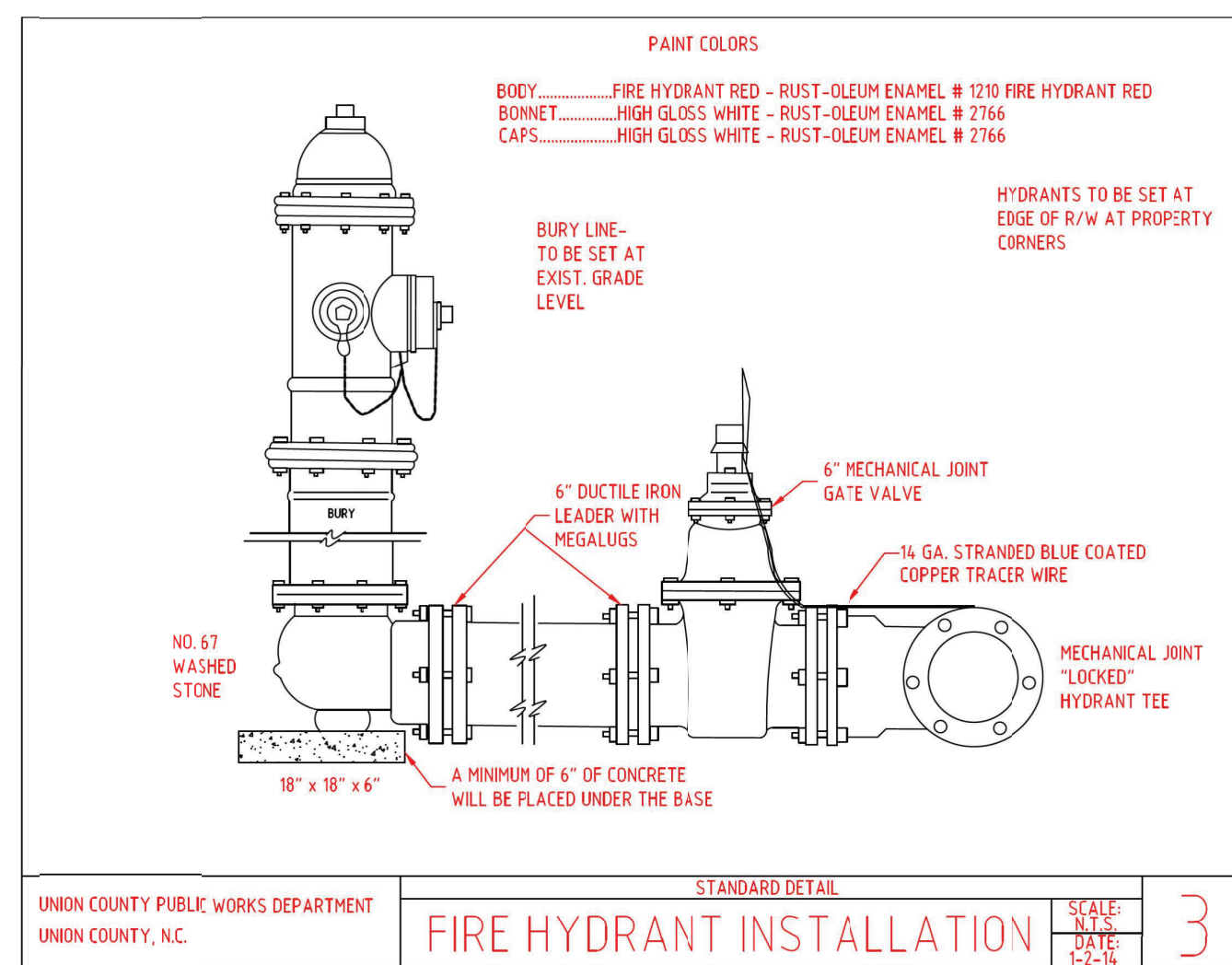
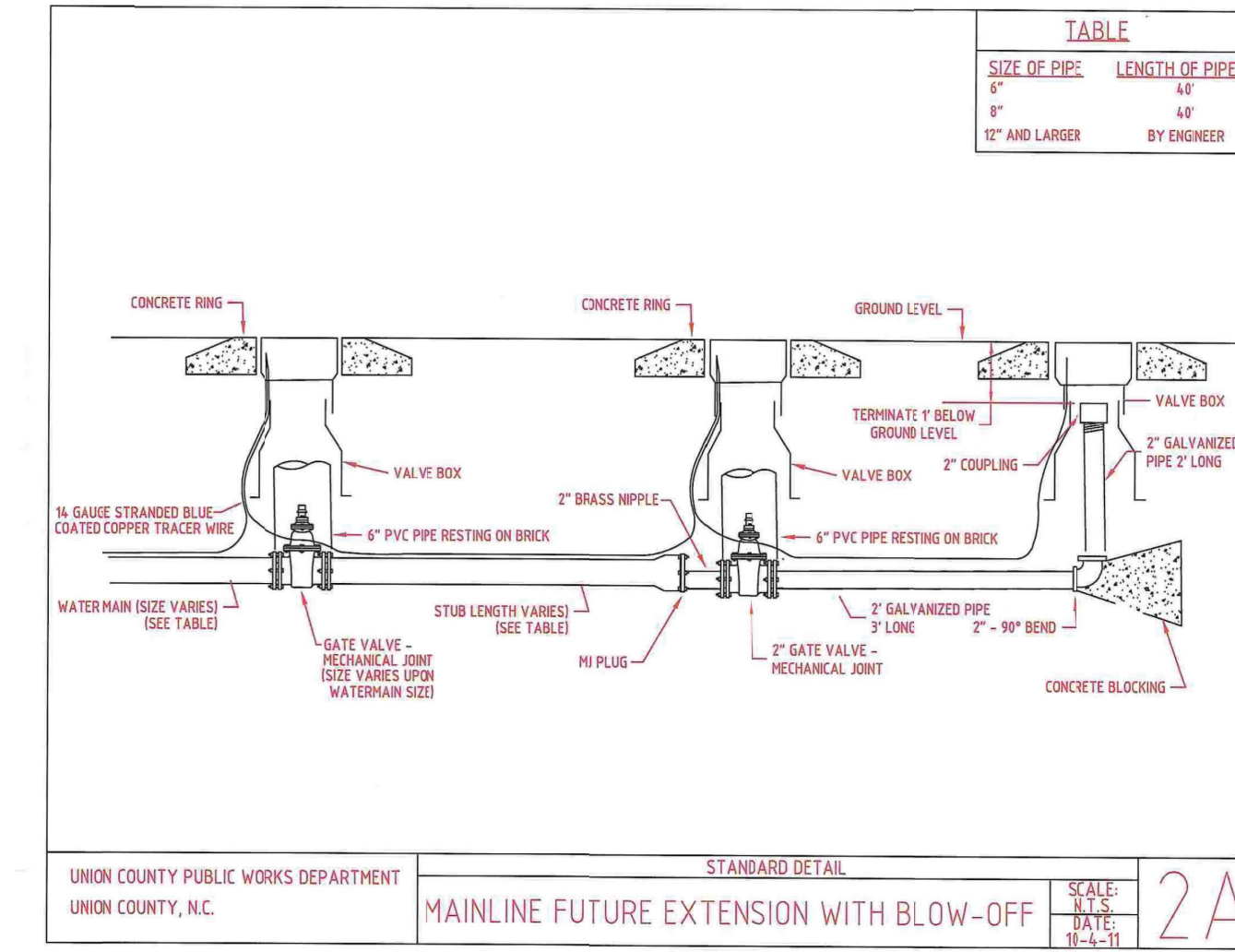

REVISIONS

1/17/2024

