

TOP OF CAP

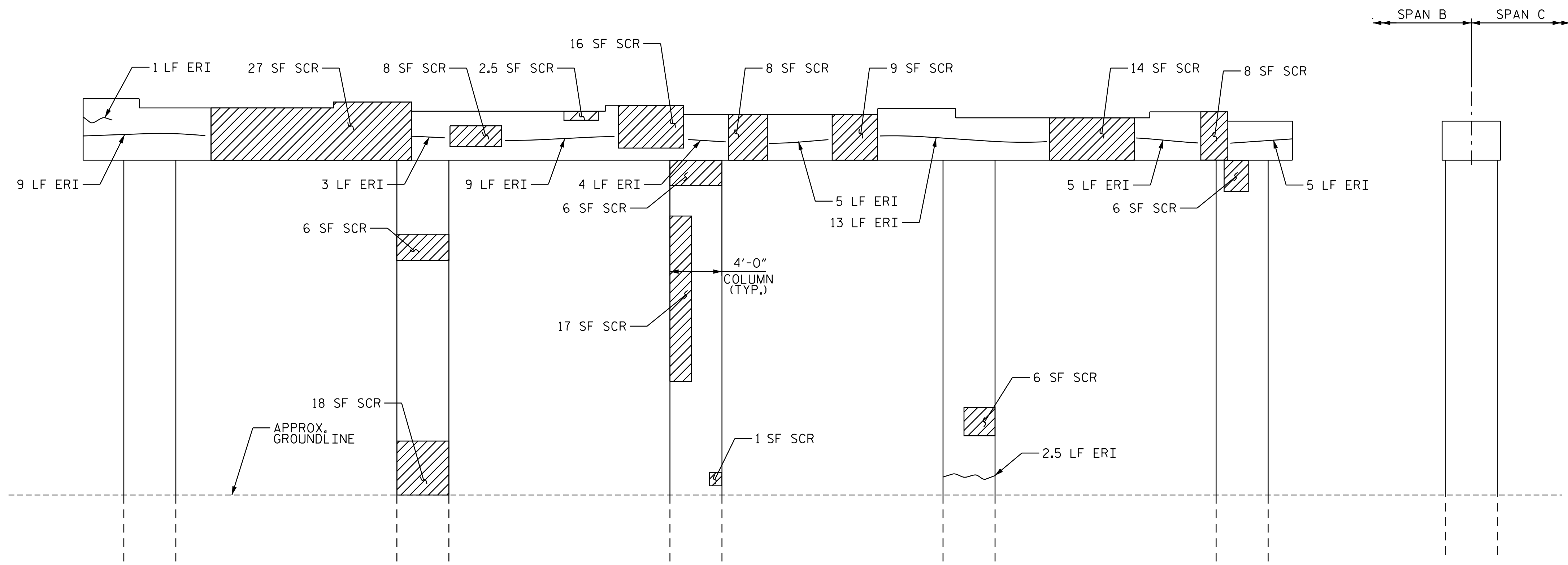

ELEVATION

END VIEW

BENT NO. 2
SPAN B FACE

AS-BUILT REPAIR QUANTITY TABLE				
BENT 2 SPAN B FACE	QUANTITIES			
	ESTIMATE		ACTUAL	
SHOTCRETE REPAIRS	AREA SF	VOLUME CF	AREA SF	VOLUME CF
CAP	92.5	23.0		
COLUMN	60.0	15.0		
CONCRETE REPAIRS	AREA SF	VOLUME CF	AREA SF	VOLUME CF
CAP	0.0	0.0		
EPOXY RESIN INJECTION	LN. FT.		LN. FT.	
CAP	58.0			
COLUMN	2.5			
EPOXY COATING	SQ. FT.		SQ. FT.	
TOP OF BENT CAP	409.0			

NOTES:

REPAIR LOCATIONS AND ESTIMATE OF QUANTITIES ARE BASED ON THE BEST INFORMATION AVAILABLE. IF ADDITIONAL REPAIRS NOT SHOWN ON THE DRAWINGS ARE DEEMED NECESSARY BY THE ENGINEER, THE ENGINEER WILL NOTE ON THE DRAWINGS THE APPROXIMATE LOCATIONS AND DESCRIPTION OF THE REPAIRS AND ENTER THE ACTUAL QUANTITIES INTO THE AS-BUILT REPAIR QUANTITY TABLE.

CLEAN AND REMOVE DEBRIS FROM THE TOP OF THE CAP AND APPLY EPOXY PROTECTIVE COATING. EPOXY COATING SHALL BE APPLIED TO THE TOP SURFACE OF THE CAP. THE CONTRACTOR SHALL NOT COAT THE AREA OF THE CAP BENEATH THE MASONRY PLATES. FOR EPOXY COATING, SEE SPECIAL PROVISIONS.

SHOTCRETE REPAIRS MAY BE REPLACED WITH CONCRETE REPAIRS WITH THE APPROVAL OF THE ENGINEER.

FOR CAP AND COLUMN REPAIRS, SEE "TYPICAL CAP AND COLUMN REPAIR DETAILS", SHEET.

FOR SHOTCRETE REPAIR, SEE SPECIAL PROVISIONS.

FOR CONCRETE REPAIR, SEE SPECIAL PROVISIONS.

FOR EPOXY RESIN INJECTION, SEE SPECIAL PROVISIONS.

- SHOTCRETE REPAIR (SCR)
- CONCRETE REPAIR (CR)
- EPOXY RESIN INJECTION (ERI)

PROJECT NO. I-5941
DURHAM COUNTY
 BRIDGE NO. 310429

SHEET 4 OF 10

DOCUMENT NOT CONSIDERED FINAL UNLESS ALL SIGNATURES COMPLETED

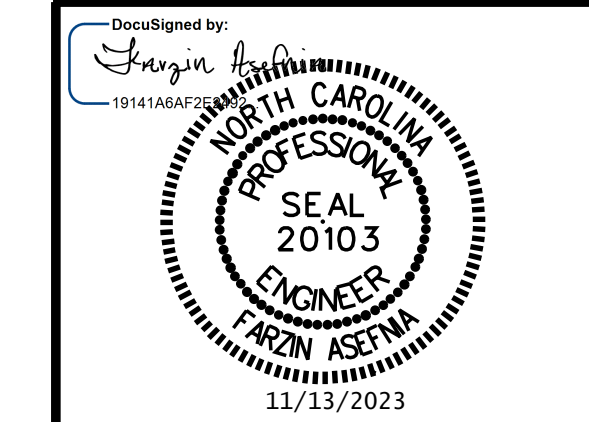

STATE OF NORTH CAROLINA
 DEPARTMENT OF TRANSPORTATION
 RALEIGH
SUBSTRUCTURE REPAIR
BENT 2 SPAN B FACE

REVISIONS						SHEET NO.
NO.	BY:	DATE:	NO.	BY:	DATE:	
1			3			S5-11
2			4			
						TOTAL SHEETS
						17

DRAWN BY : M. HOGAN DATE : 3/2023
 CHECKED BY : JIA XU DATE : 7/2023
 DESIGN ENGINEER OF RECORD: F. ASEFNIA DATE : 11/2023

E.L. ROBINSON
 3362 Old Forks Rd.
 Raleigh, N.C. 27609
 Tel: 984.980.2810
 efl@elrobinsonengineering.com
 License: C-22 9