

TOP OF CAP

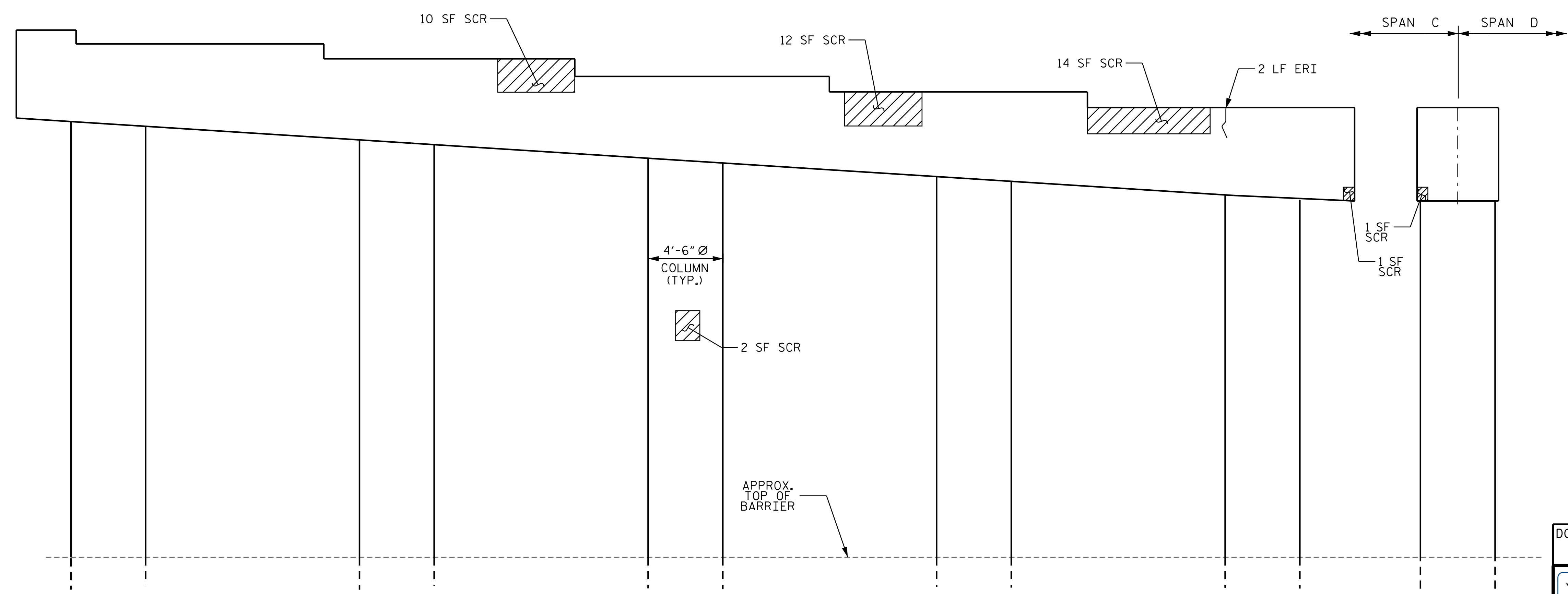

ELEVATION

END VIEW

BENT NO. 3
SPAN C FACE

AS-BUILT REPAIR QUANTITY TABLE				
BENT 3 SPAN C FACE	QUANTITIES			
	ESTIMATE		ACTUAL	
SHOTCRETE REPAIRS	AREA SF	VOLUME CF	AREA SF	VOLUME CF
CAP	38.0	9.5		
COLUMN	2.0	0.5		
CONCRETE REPAIRS	AREA SF	VOLUME CF	AREA SF	VOLUME CF
CAP	16.0	4.0		
EPOXY RESIN INJECTION	LN. FT.		LN. FT.	
CAP	23.5			
COLUMN	0.0			
EPOXY COATING	SQ. FT.		SQ. FT.	
TOP OF BENT CAP	365.0			

NOTES:

REPAIR LOCATIONS AND ESTIMATE OF QUANTITIES ARE BASED ON THE BEST INFORMATION AVAILABLE. IF ADDITIONAL REPAIRS NOT SHOWN ON THE DRAWINGS ARE DEEMED NECESSARY BY THE ENGINEER, THE ENGINEER WILL NOTE ON THE DRAWINGS THE APPROXIMATE LOCATIONS AND DESCRIPTION OF THE REPAIRS AND ENTER THE ACTUAL QUANTITIES INTO THE AS-BUILT REPAIR QUANTITY TABLE.

CLEAN AND REMOVE DEBRIS FROM THE TOP OF THE CAP AND APPLY EPOXY PROTECTIVE COATING. EPOXY COATING SHALL BE APPLIED TO THE TOP SURFACE OF THE CAP. THE CONTRACTOR SHALL NOT COAT THE AREA OF THE CAP BENEATH THE MASONRY PLATES. FOR EPOXY COATING, SEE SPECIAL PROVISIONS.

SHOTCRETE REPAIRS MAY BE REPLACED WITH CONCRETE REPAIRS WITH THE APPROVAL OF THE ENGINEER.

FOR CAP AND COLUMN REPAIRS, SEE "TYPICAL CAP AND COLUMN REPAIR DETAILS", SHEET.

FOR SHOTCRETE REPAIR, SEE SPECIAL PROVISIONS.

FOR CONCRETE REPAIR, SEE SPECIAL PROVISIONS.

FOR EPOXY RESIN INJECTION, SEE SPECIAL PROVISIONS.

- SHOTCRETE REPAIR (SCR)
- CONCRETE REPAIR (CR)
- EPOXY RESIN INJECTION (ERI)

PROJECT NO. I-5941

DURHAM COUNTY

BRIDGE NO. 310135

SHEET 6 OF 8

DOCUMENT NOT CONSIDERED FINAL UNLESS ALL SIGNATURES COMPLETED

DocuSigned by:
Farzin Asefnia
10141AB47

11/13/2023

STATE OF NORTH CAROLINA
DEPARTMENT OF TRANSPORTATION
RALEIGH

SUBSTRUCTURE REPAIR
BENT 3 SPAN C FACE

DRAWN BY :	M. HOGAN	DATE :	3/2023
CHECKED BY :	JIA XU	DATE :	7/2023
DESIGN ENGINEER OF RECORD:	F. ASEFNIA	DATE :	11/2023

REVISIONS						SHEET NO. S3-16
NO.	BY:	DATE:	NO.	BY:	DATE:	
1			3			TOTAL SHEETS 18
2			4			