

PROJ. REFERENCE NO.	SHEET NO.
I-5941	TMP-30

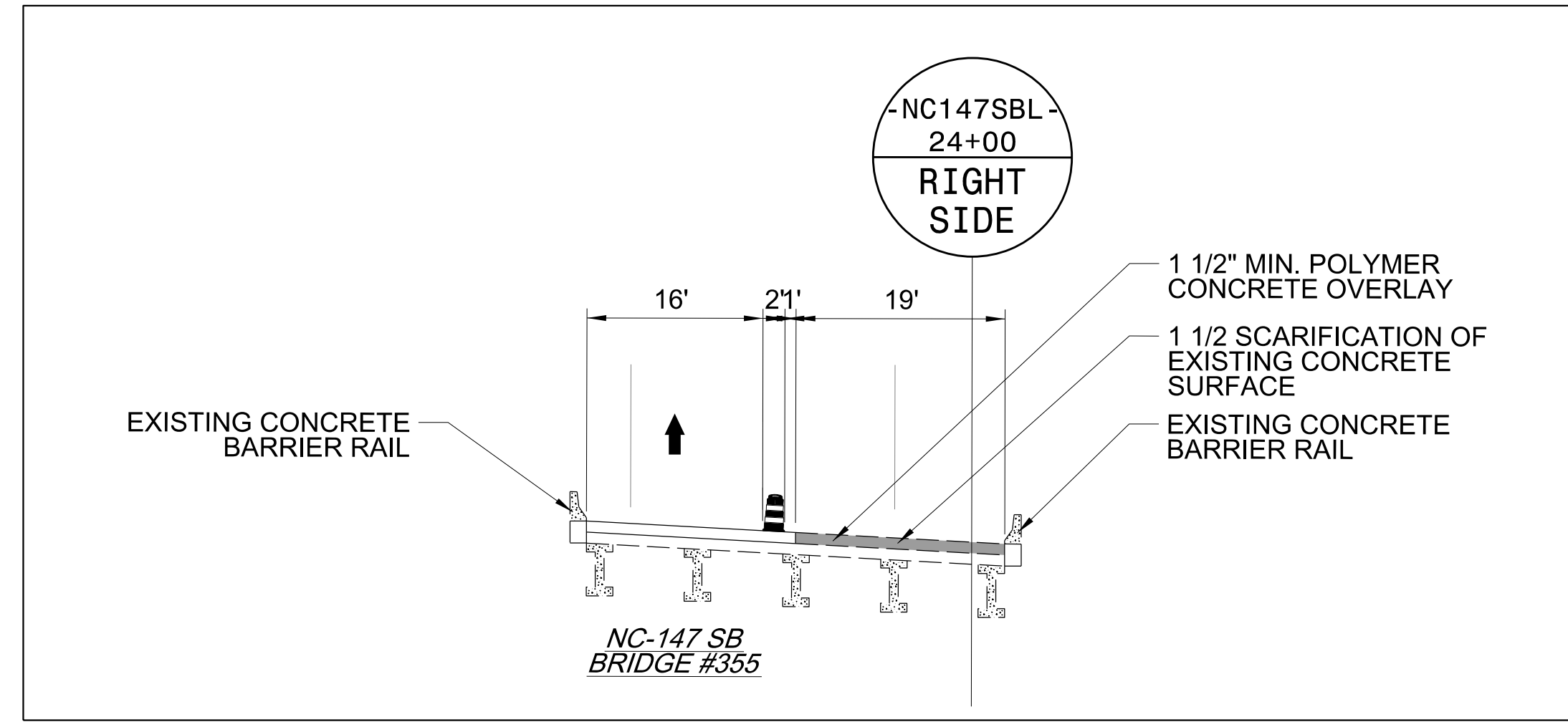
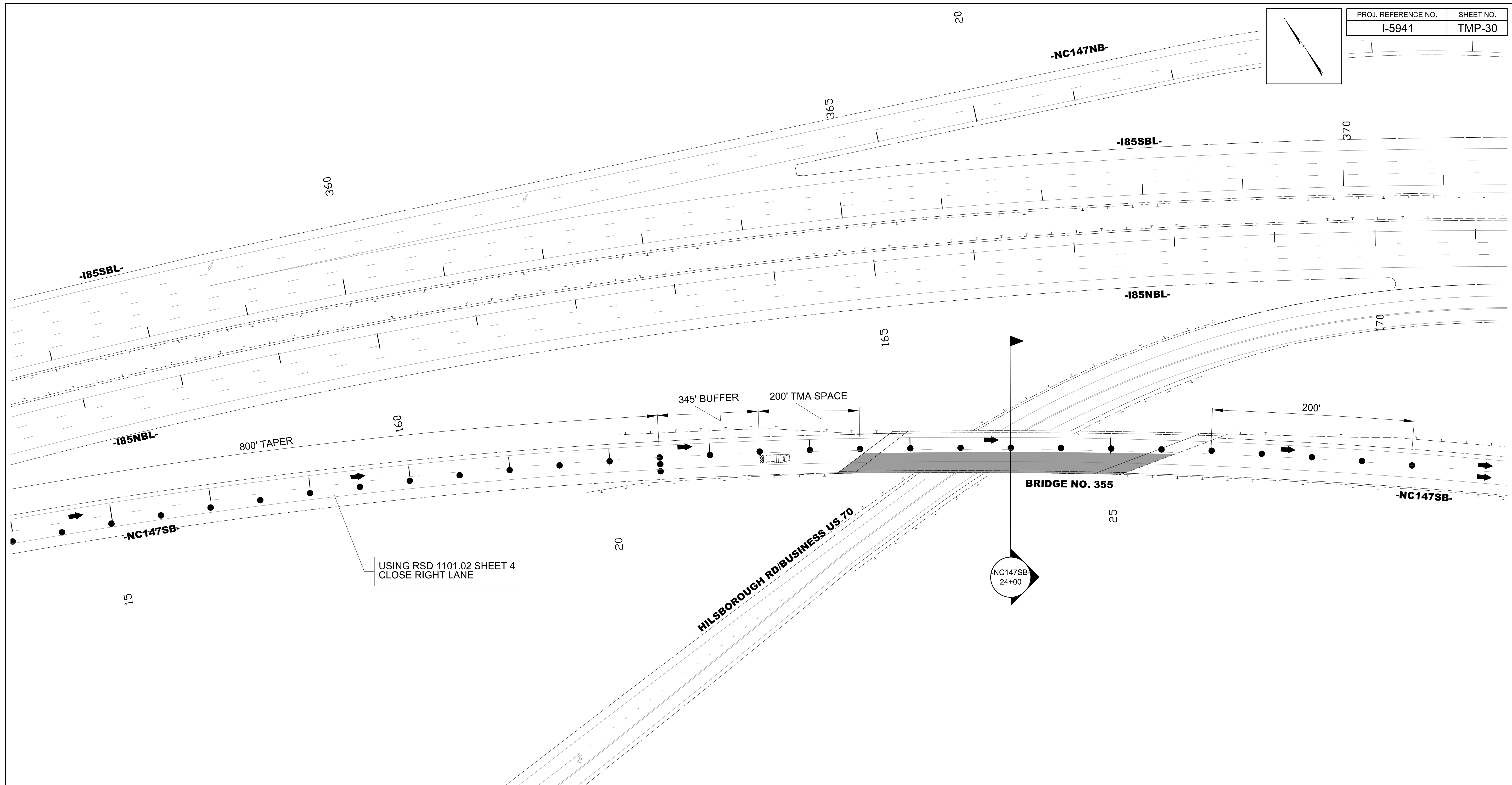
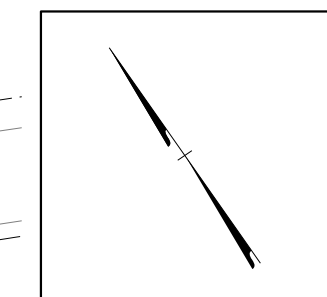

11/14/2023
 U:\Traffic\Transportation Management Plan\TCP\PLAN SHEETS\I-5941\TMP_30\NC_147_SB.dgn
 angood

Stantec

Stantec Consulting Services Inc.
 801 Jones Franklin Road
 Suite 300
 Raleigh, NC 27606
 Tel. 919.851.6866
 Fax. 919.851.7024
 www.stantec.com
 License No. F-0672

11/14/2023

**DOCUMENT NOT CONSIDERED FINAL
 UNLESS ALL SIGNATURES COMPLETED**

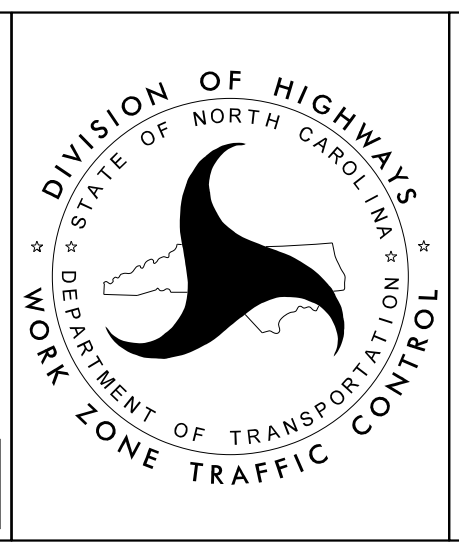

**NC-147 SOUTHBOUND
 -NC147SB-
 BRIDGE REHABILITATION
 RIGHT SIDE**