

ONSITE CONCRETE WASHOUT STRUCTURE WITH LINER

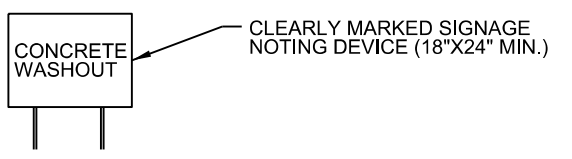
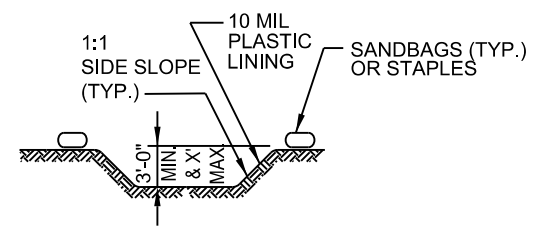
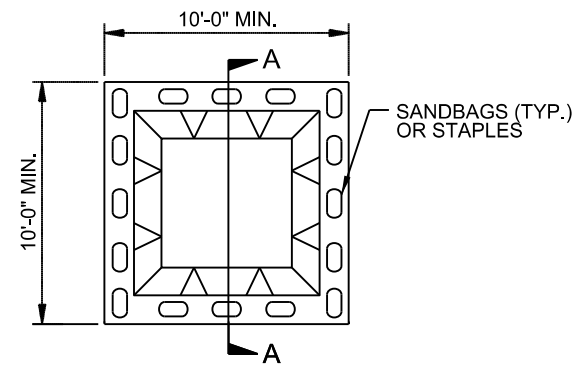

- SECTION A-A**
- NOTES:**
1. ACTUAL LOCATION DETERMINED IN FIELD
 2. THE CONCRETE WASHOUT STRUCTURES SHALL BE MAINTAINED WHEN THE LIQUID AND/OR SOLID REACHES 75% OF THE STRUCTURES CAPACITY.
 3. CONCRETE WASHOUT STRUCTURE NEEDS TO BE CLEARLY MARKED WITH SIGNAGE NOTING DEVICE.

PLAN

BELOW GRADE WASHOUT STRUCTURE NOT TO SCALE

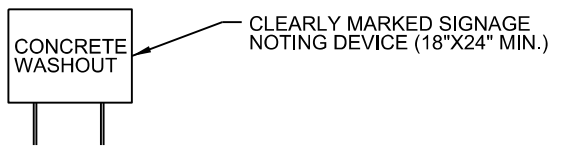
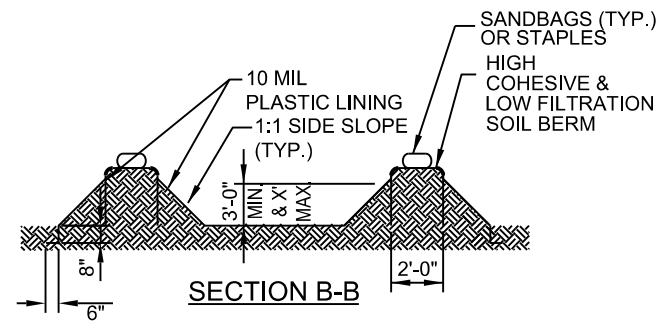
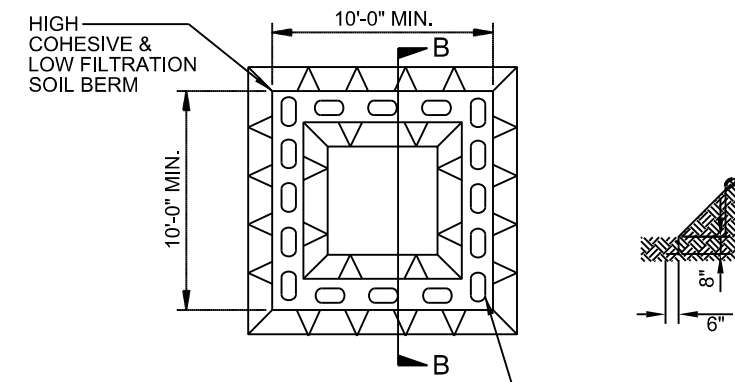

- SECTION B-B**
- NOTES:**
1. ACTUAL LOCATION DETERMINED IN FIELD
 2. THE CONCRETE WASHOUT STRUCTURES SHALL BE MAINTAINED WHEN THE LIQUID AND/OR SOLID REACHES 75% OF THE STRUCTURES CAPACITY TO PROVIDE ADEQUATE HOLDING CAPACITY WITH A MINIMUM 12 INCHES OF FREEBOARD.
 3. CONCRETE WASHOUT STRUCTURE NEEDS TO BE CLEARLY MARKED WITH SIGNAGE NOTING DEVICE.

PLAN

ABOVE GRADE WASHOUT STRUCTURE NOT TO SCALE