

PLAN

TOP OF PILE ELEVATIONS	
⑧	721.63
⑨	721.44
⑩	721.24
⑪	721.05
⑫	720.86
⑬	720.67

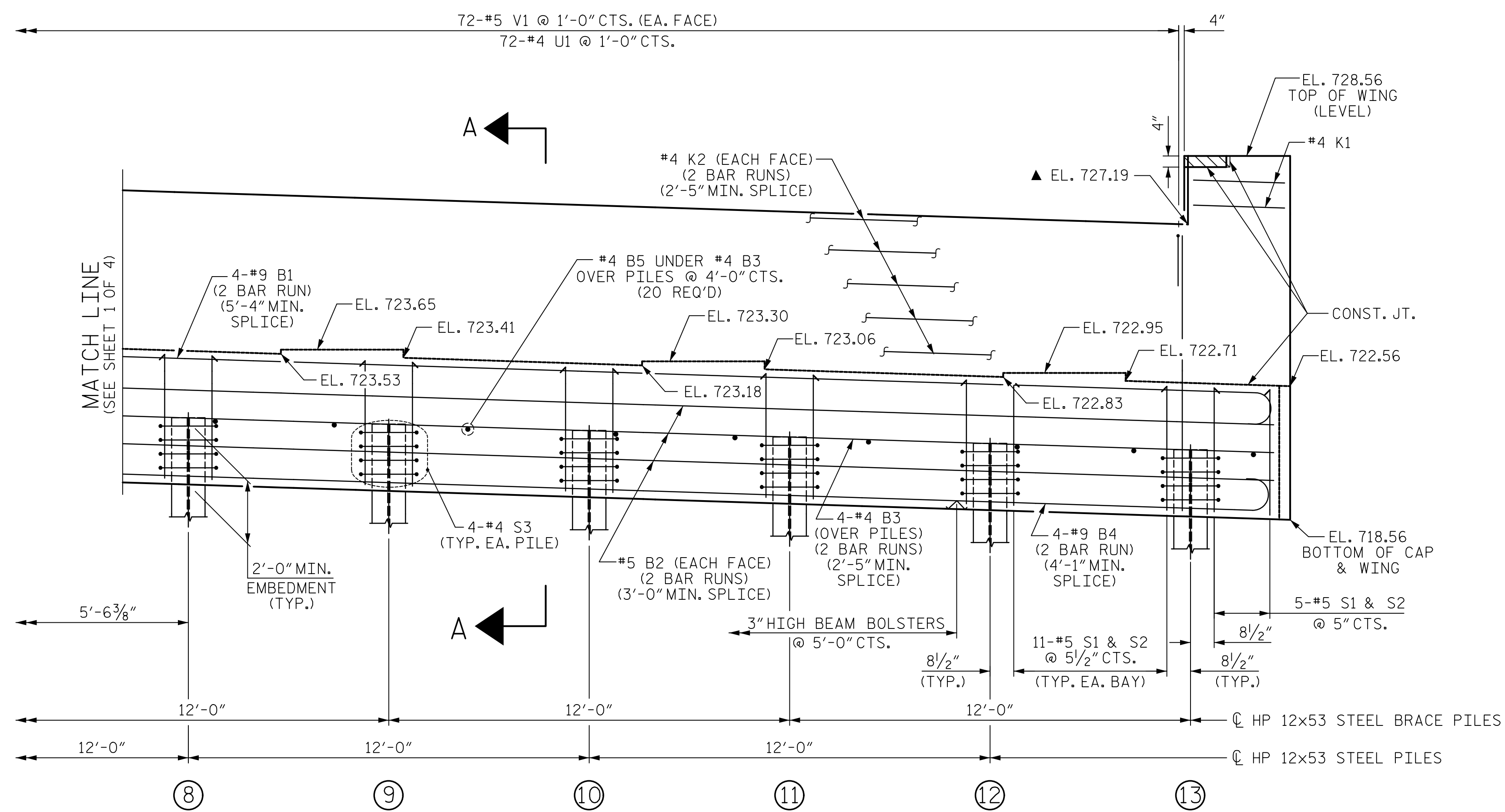

ELEVATION

WINGS NOT SHOWN FOR CLARITY.
 FOR SECTION A-A, SEE SHEET 4 OF 4.
 CONCRETE COLLARS FOR STEEL PILES NOT SHOWN IN PLAN AND ELEVATION VIEWS FOR CLARITY.
 SEE "CORROSION PROTECTION FOR STEEL PILES DETAIL", SHEET 4 OF 4.



111 E. Hargett Street
 Suite 300
 Raleigh, NC 27601
 919-714-8670
 meadhunt.com
 NC License No. F-1235

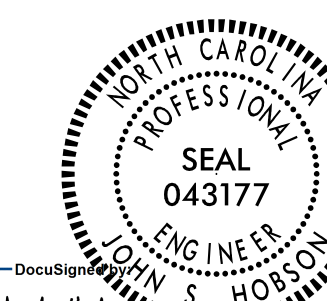

DocuSign
 Jack Hobson
 10/5/2023
 00DFC8B1D45F40E

DOCUMENT NOT CONSIDERED
 FINAL UNLESS ALL
 SIGNATURES COMPLETED

PROJECT NO. U-5808
UNION COUNTY
 STATION: 55+00.96 -L2-

SHEET 2 OF 4

STATE OF NORTH CAROLINA
 DEPARTMENT OF TRANSPORTATION
 RALEIGH
 SUBSTRUCTURE

END BENT 1

REVISIONS

NO.	BY:	DATE:	NO.	BY:	DATE:	SHEET NO.
1			3			S-39
2			4			TOTAL SHEETS
						56

DRAWN BY : C.C. CAMPBELL DATE : 05/10/23
 CHECKED BY : J.S. HOBSON DATE : 06/21/23
 DESIGN ENGINEER OF RECORD : J.S. HOBSON DATE : 08/30/23