

POURING SEQUENCE
 # DENOTES POUR NUMBER AND DIRECTION

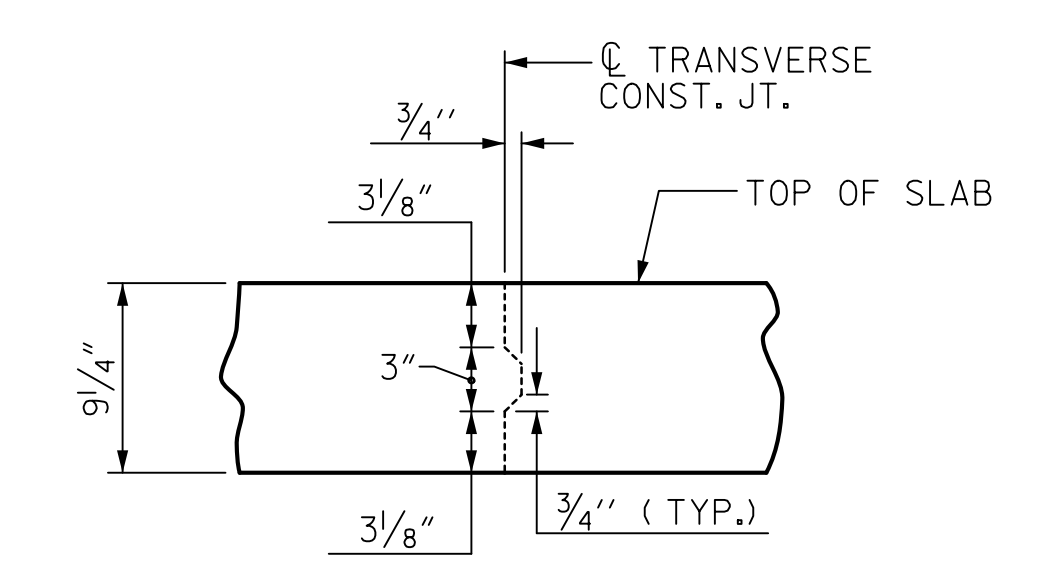

TRANSVERSE CONSTRUCTION JOINT DETAIL

NOTE: REINFORCING STEEL IN SLAB NOT SHOWN. LONGITUDINAL REINFORCING STEEL SHALL BE CONTINUOUS THRU JOINT

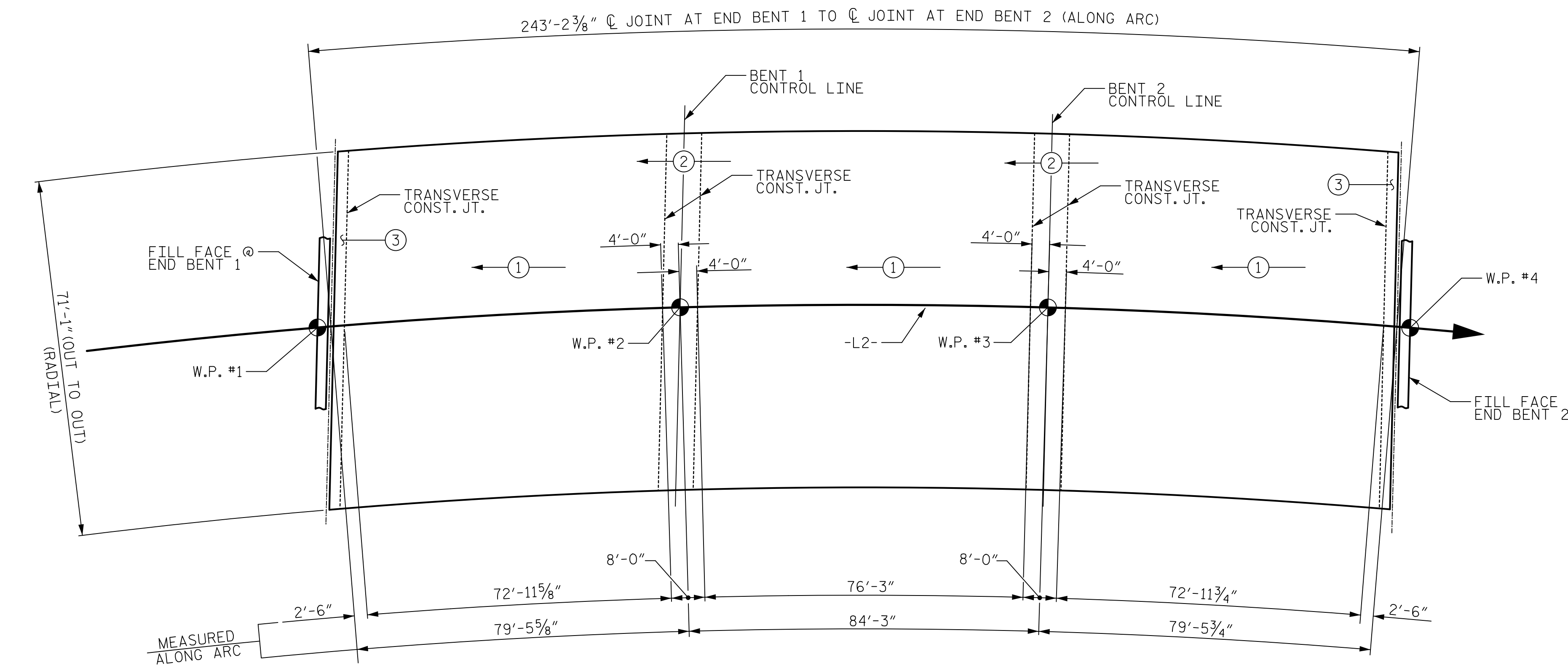

OPTIONAL POURING SEQUENCE
 # DENOTES POUR NUMBER AND DIRECTION

POUR ② CAN NOT BE STARTED UNTIL BOTH ADJACENT ① POURS REACH A MINIMUM OF 3000 PSI.



111 E. Hargett Street
 Suite 300
 Raleigh, NC 27601
 919-714-8670
 meadhunt.com
 NC License No. F-1235

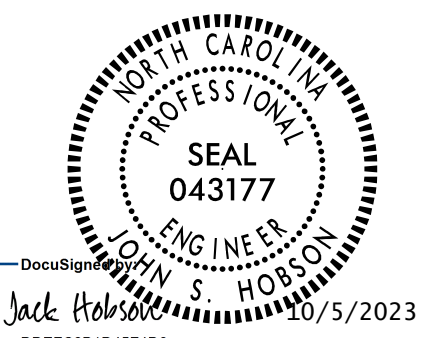

PROJECT NO. U-5808
UNION COUNTY
 STATION: 55+00.96 -L2-

STATE OF NORTH CAROLINA
 DEPARTMENT OF TRANSPORTATION
 RALEIGH
 SUPERSTRUCTURE
 POUR SEQUENCE

DRAWN BY : J.S. HOBSON DATE : 06/05/23
 CHECKED BY : J.A. BOYER DATE : 06/29/23
 DESIGN ENGINEER OF RECORD : J.S. HOBSON DATE : 08/30/23

DOCUMENT NOT CONSIDERED FINAL UNLESS ALL SIGNATURES COMPLETED

REVISIONS						SHEET NO.
NO.	BY:	DATE:	NO.	BY:	DATE:	S-36
1			3			TOTAL SHEETS
2			4			56