

DETAIL "A"

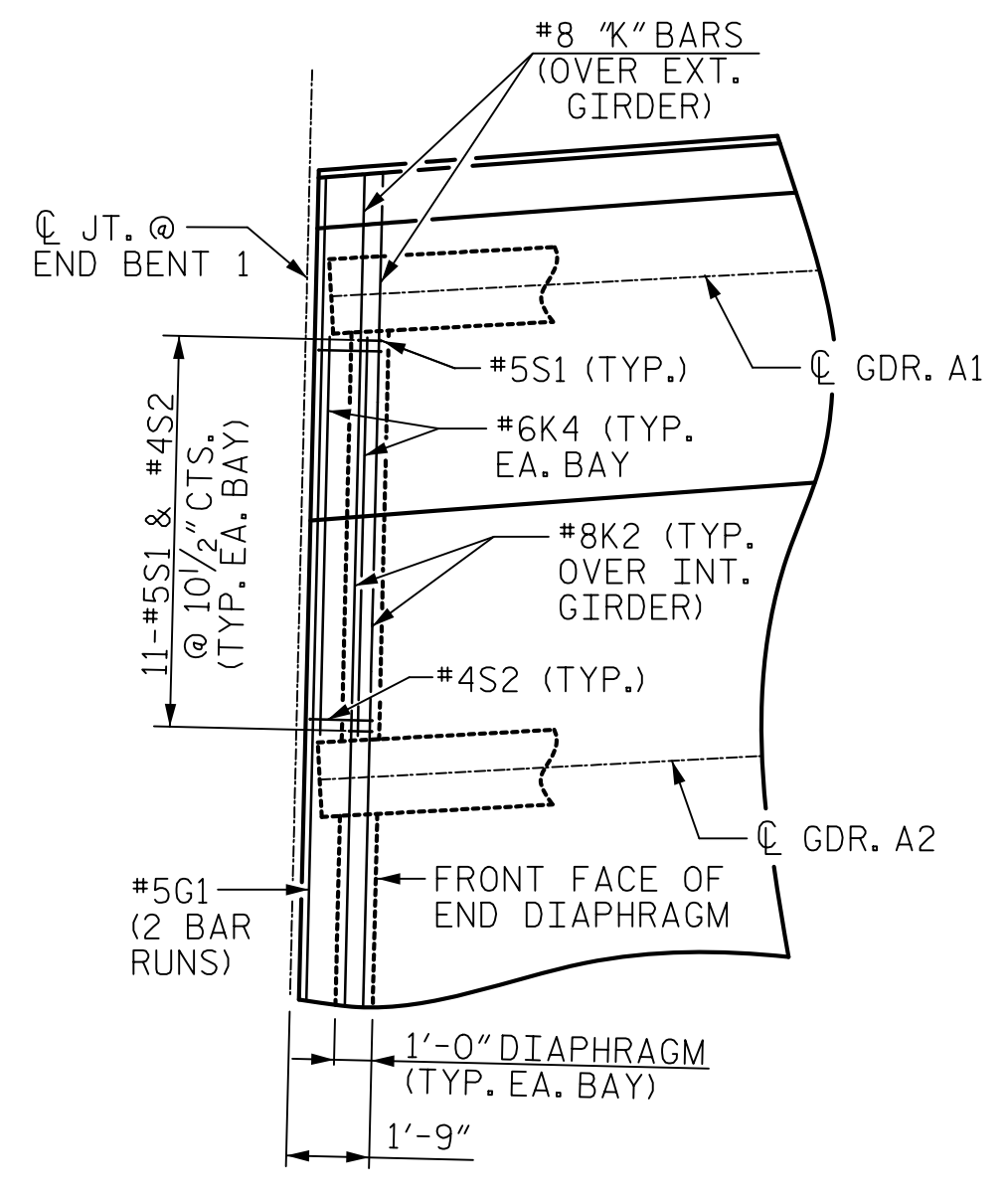

DETAIL "B"

"A" & "B" BARS NOT SHOWN

PROJECT NO. U-5808

UNION COUNTY

STATION: 55+00.96 -L2-

SHEET 1 OF 3

STATE OF NORTH CAROLINA
DEPARTMENT OF TRANSPORTATION
RALEIGH

SUPERSTRUCTURE
PLAN OF SPANS

REVISIONS					
NO.	BY:	DATE:	NO.	BY:	DATE:
1			3		
2			4		

SHEET NO.
S-09
TOTAL SHEETS
56

DRAWN BY: J.S. HOBSON DATE: 05/23/23
 CHECKED BY: J.A. BOYER DATE: 06/29/23
 DESIGN ENGINEER OF RECORD: J.S. HOBSON DATE: 08/30/23



111 E. Hargett Street
Suite 300
Raleigh, NC 27601
919-714-8670
meadhunt.com
NC License No. F-1235

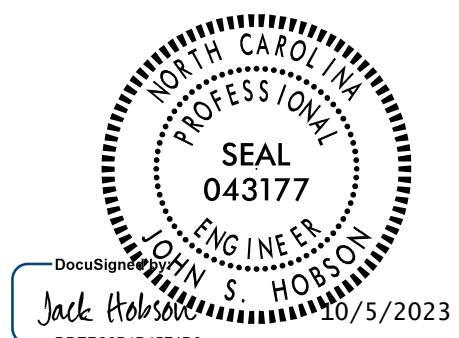

DOCUMENT NOT CONSIDERED FINAL UNLESS ALL SIGNATURES COMPLETED