

**NOTES**

STIRRUPS AND "U" BARS IN CAP MAY BE SHIFTED AS NECESSARY TO CLEAR ANCHOR BOLTS.

HOOKS ON "V" BARS MAY BE TURNED AS NECESSARY FOR PLACING REINFORCING STEEL.

ALL STEEL IN THE DRILLED PIERS IS INCLUDED IN THE PAY ITEMS FOR "REINFORCING STEEL" AND "SPIRAL COLUMN REINFORCING STEEL".

THE CONTRACTOR'S ATTENTION IS CALLED TO THE FACT THAT THE LONGITUDINAL REINFORCEMENT FOR THE DRILLED PIERS IS DETAILED WITH 3 FEET OF EXTRA LENGTH.

THE LOCATION OF THE CONSTRUCTION JOINT IN THE DRILLED PIERS IS BASED ON AN APPROXIMATE GROUND LINE ELEVATION. IF THE CONSTRUCTION JOINT IS ABOVE THE ACTUAL GROUND ELEVATION, THE CONTRACTOR SHALL PLACE THE CONSTRUCTION JOINT 1 FOOT BELOW THE GROUND LINE.

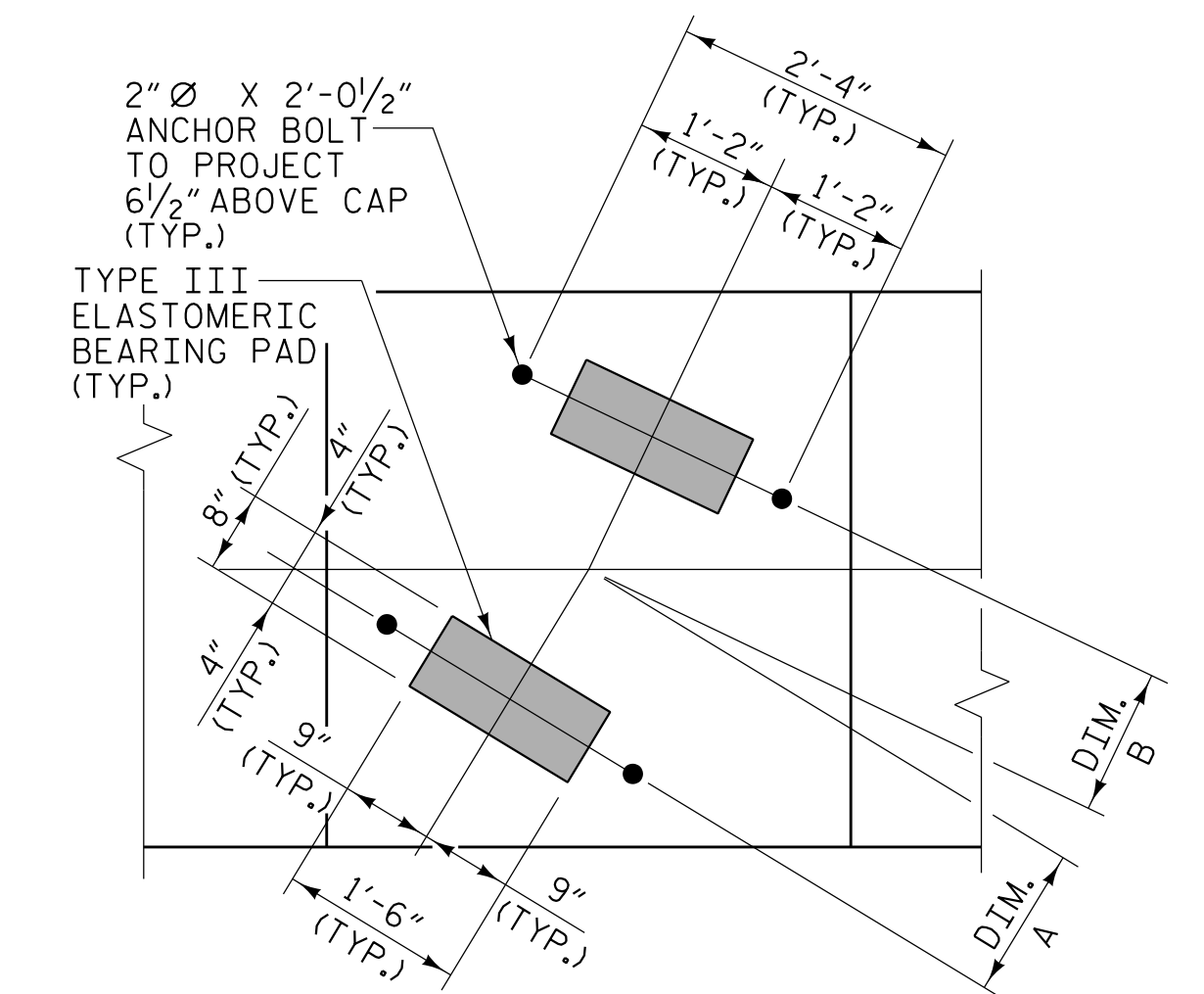

**DETAIL "A"**  
(TYP. EACH GIRDER)

SPAN A		SPAN B	
GIRDER NO.	DIM. A	GIRDER NO.	DIM. B
GDR. A1	1'-3 3/8"	GDR. B1	1'-2 3/4"
GDR. A2	1'-2 5/8"	GDR. B2	1'-2 1/16"
GDR. A3	1'-2"	GDR. B3	1'-2 5/8"
GDR. A4	1'-1 5/8"	GDR. B4	1'-2 9/16"
GDR. A5	1'-1 9/16"	GDR. B5	1'-2 1/2"
GDR. A6	1'-1 3/4"	GDR. B6	1'-2 7/16"
GDR. A7	1'-2 3/16"	GDR. B7	1'-2 3/8"
GDR. A8	1'-2 3/4"	GDR. B8	1'-2 5/16"
GDR. A9	1'-3 3/16"	GDR. B9	1'-2 1/4"

DIM. A & B MEASURED ALONG C GIRDER

PROJECT NO. U-5839  
**HAYWOOD COUNTY**  
 STATION: 24+64.13 -L- POC

SHEET 1 OF 4

STATE OF NORTH CAROLINA  
 DEPARTMENT OF TRANSPORTATION  
 RALEIGH

**SUBSTRUCTURE  
 BENT 1  
 STAGE I**

REVISIONS					
NO.	BY:	DATE:	NO.	BY:	DATE:
1			3		
2			4		

SHEET NO. S1-45  
 TOTAL SHEETS 63

DocuSigned by:  
  
 BE02398D9220470  
 5/18/2023

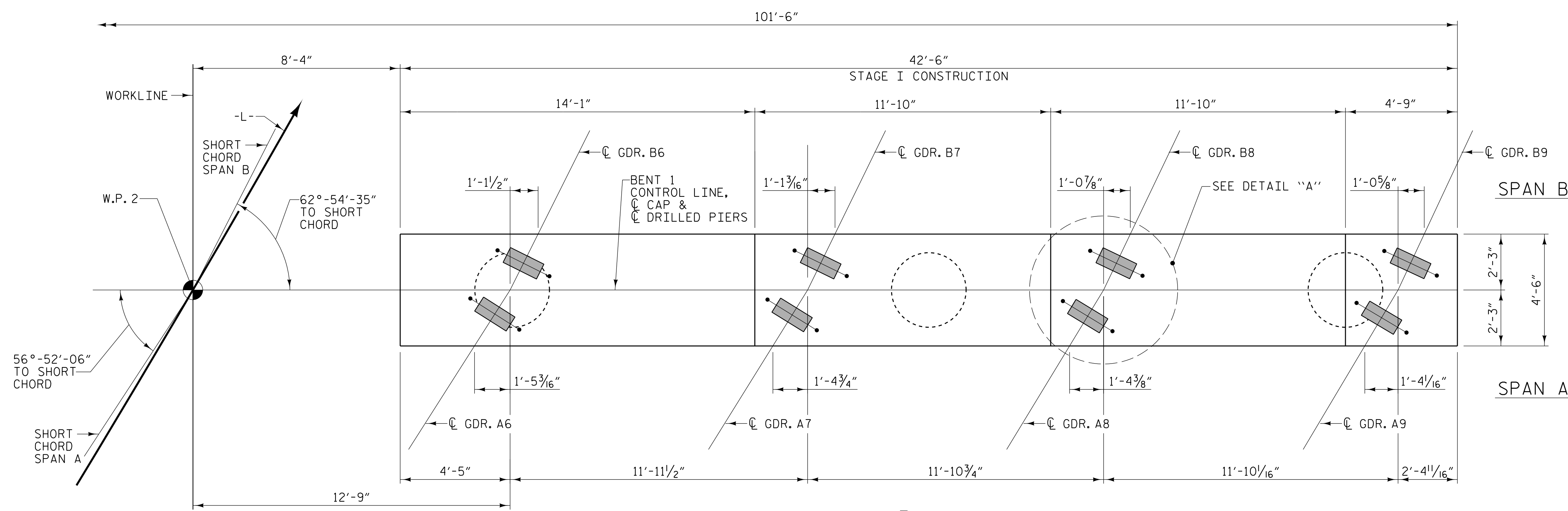

**PLAN**

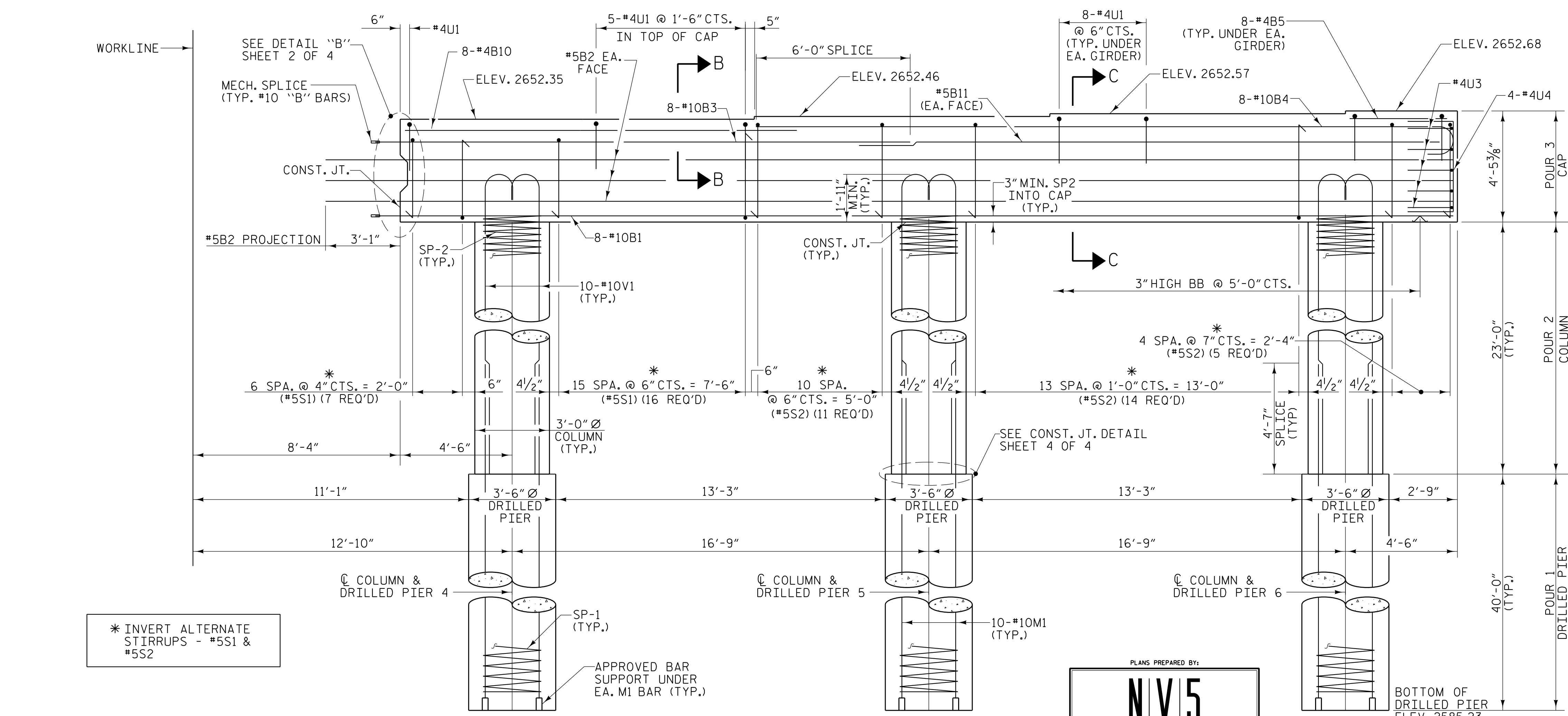

**ELEVATION**

(FOR SECTIONS B-B AND C-C, SEE SHEET 4 OF 4)

PLANS PREPARED BY:  
**NV5**  
 NV5 ENGINEERS & CONSULTANTS, INC.  
 3300 REGENCY PARKWAY, SUITE 100  
 CARY, NC 27518  
 P: 919.851.1912 www.NV5.com  
 NC License # F-1333

**DOCUMENT NOT CONSIDERED FINAL  
 UNLESS ALL SIGNATURES COMPLETED**

5/17/2023 RA\Structures\3 span Bridge over RR\45 US839\_SMU\_B1\_430184.dgn

DRAWN BY: W. B. ALLEN DATE: 5/20  
 CHECKED BY: Z. H. BROWN DATE: 8/20  
 DESIGN ENGINEER OF RECORD: R. C. LARSON DATE: 4/23

DocuSigned by:  
  
 BE02398D9220470