

NOTE:
 END BENTS AND INTERIOR BENTS
 ARE NOT PARALLEL.

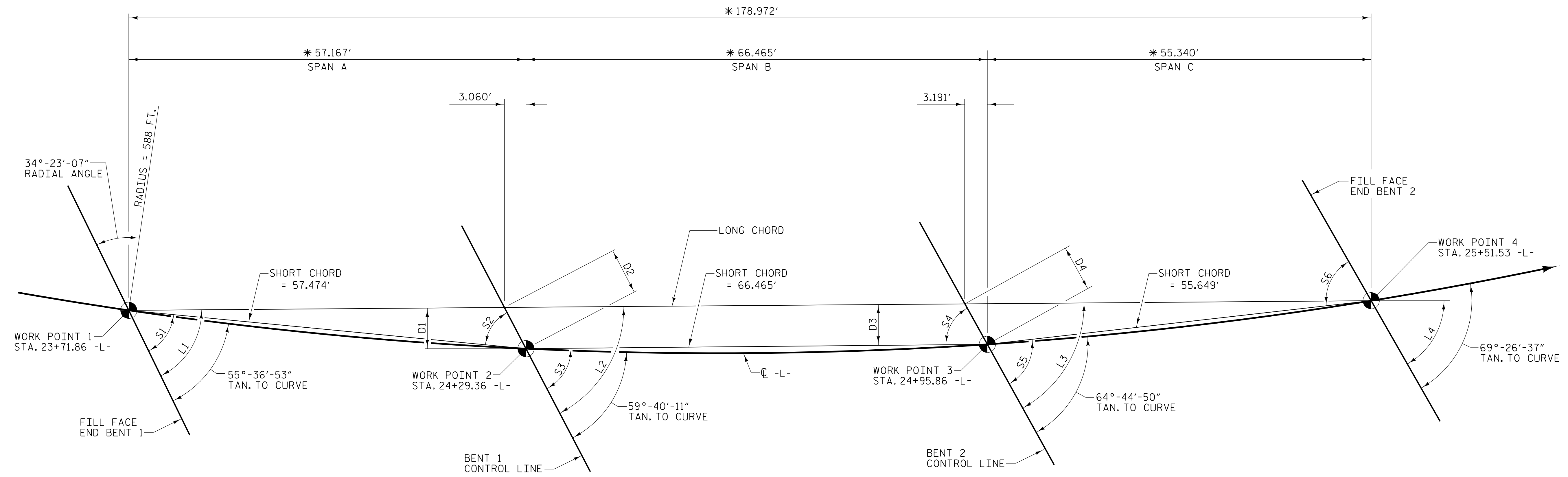

LONG CHORD LAYOUT
 * ALONG LONG CHORD

ANGLES				OFFSETS	
	LONG CHORD		SHORT CHORD		
L1	64°-22'-06"	S1	58°-24'-58"	D1	5.960'
L2	62°-49'-13"	S2	56°-52'-06"	D2	6.700'
L3	61°-25'-04"	S3	62°-54'-35"	D3	5.857'
L4	60°-41'-23"	S4	61°-30'-26"	D4	6.670'
		S5	67°-27'-33"		
		S6	66°-43'-52"		

PROJECT NO. U-5839
HAYWOOD COUNTY
 STATION: 24+64.13 -L- POC

SHEET 3 OF 5

STATE OF NORTH CAROLINA
 DEPARTMENT OF TRANSPORTATION
 RALEIGH
GENERAL DRAWING
 FOR BRIDGE ON -L- US 276
 (RUSS AVE.) OVER -Y6-
 (BLUE RIDGE SOUTHERN RAILROAD)
 BETWEEN US 23 (N. MAIN ST.)
 AND SR 1247 (DELLWOOD RD.)

PLANS PREPARED BY:

NV5 ENGINEERS & CONSULTANTS, INC.
 3300 REGENCY PARKWAY, SUITE 100
 CARY, NC 27518
 P: 919.851.1912 www.NV5.com
 NC License # F-1333

DocuSigned by:

ROBERT C. LARSON
 ENGINEER
 5/18/2023

**DOCUMENT NOT CONSIDERED FINAL
 UNLESS ALL SIGNATURES COMPLETED**

REVISIONS						SHEET NO.
NO.	BY:	DATE:	NO.	BY:	DATE:	S1-3
1			3			TOTAL SHEETS
2			4			63

DRAWN BY: W. B. ALLEN DATE: 5/19
 CHECKED BY: Z. H. BROWN DATE: 6/19
 DESIGN ENGINEER OF RECORD: R. C. LARSON DATE: 4/23

DocuSigned by:

 BEB239809220478

5/17/2023 7:04:47 PM RA:\Structures\3 span Bridge over RR\03 US276_SML\02_43084.dgn