

Welded Ring Stiffened Mast Arm Connection

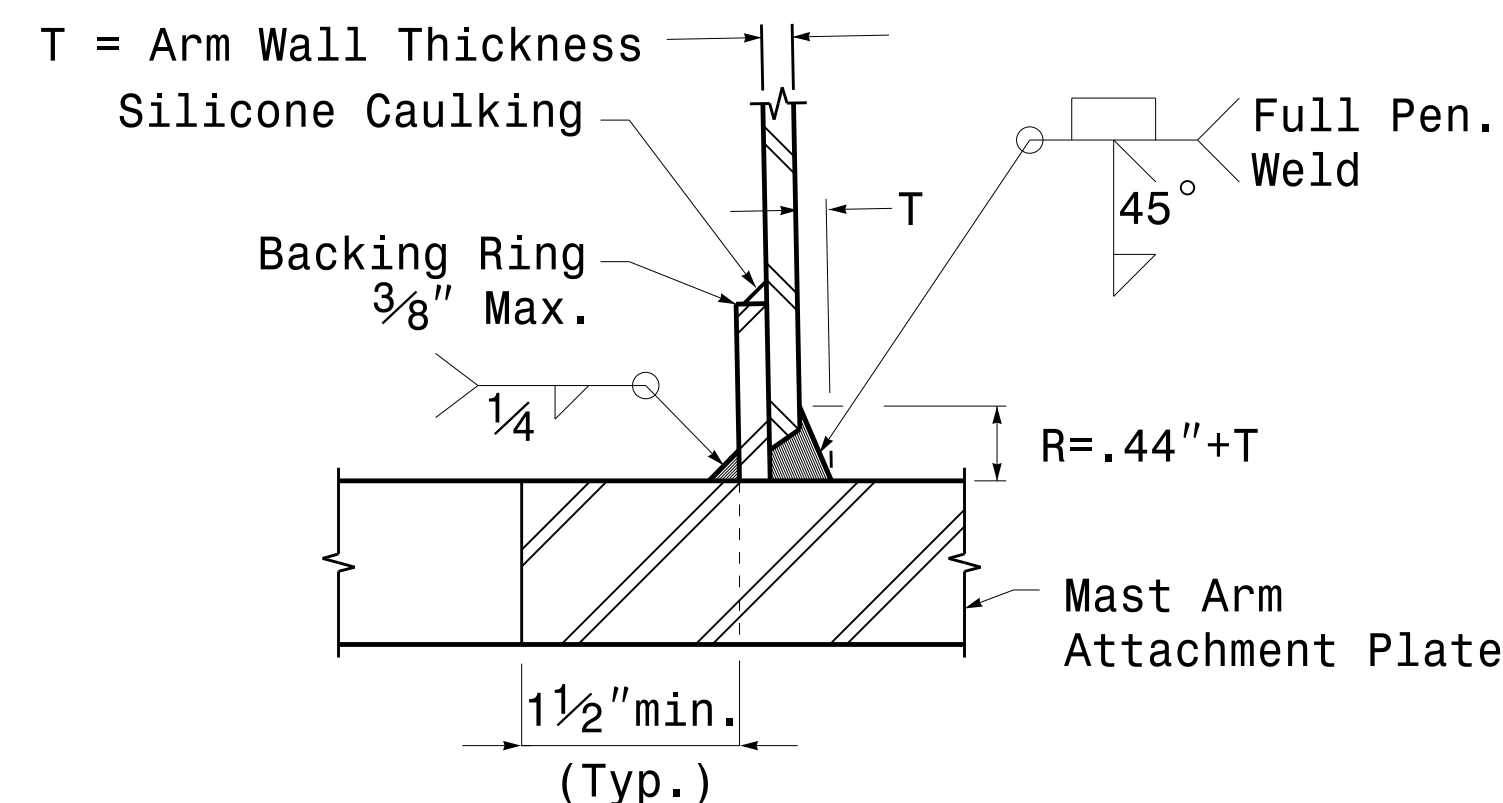
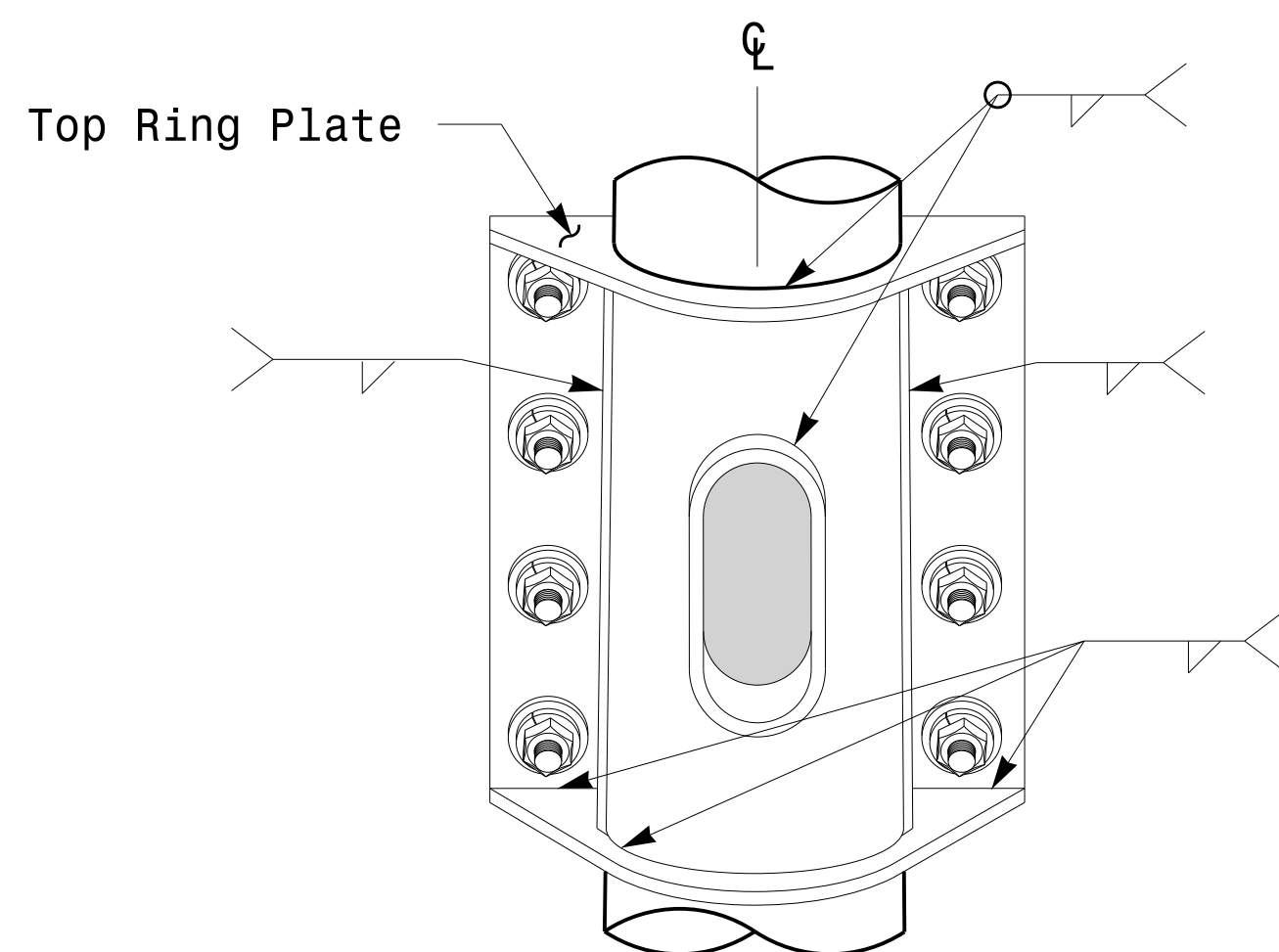
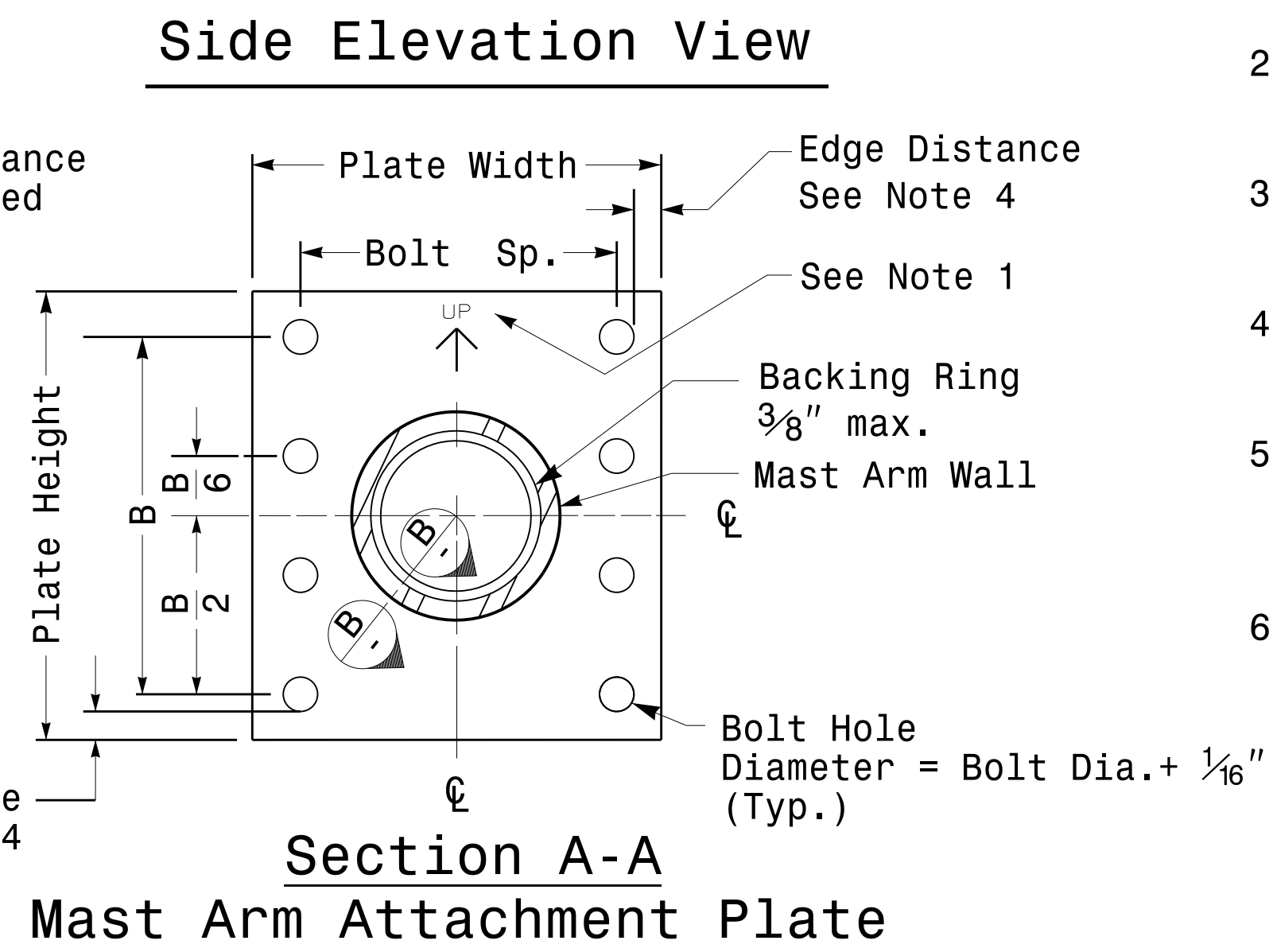
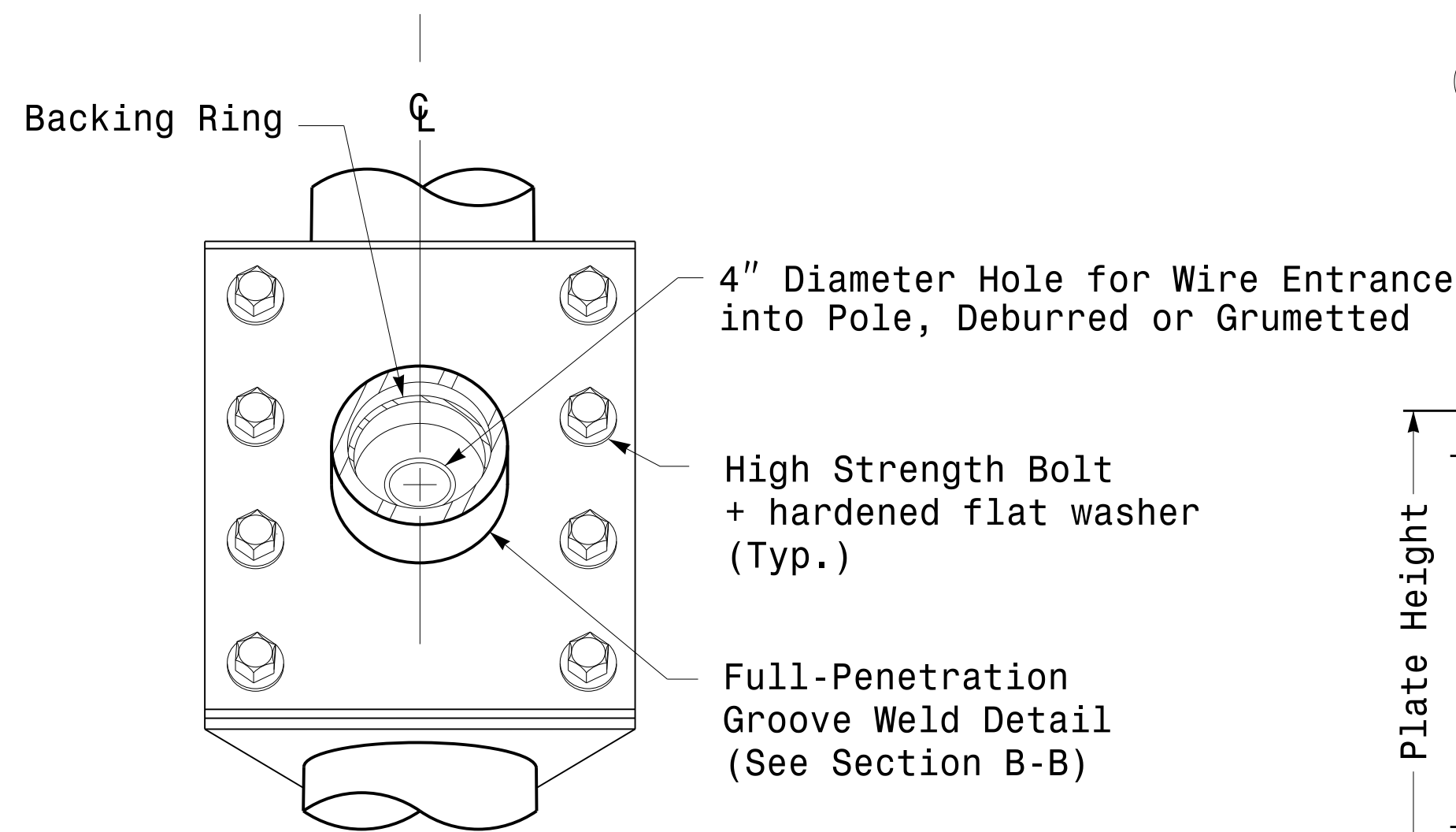
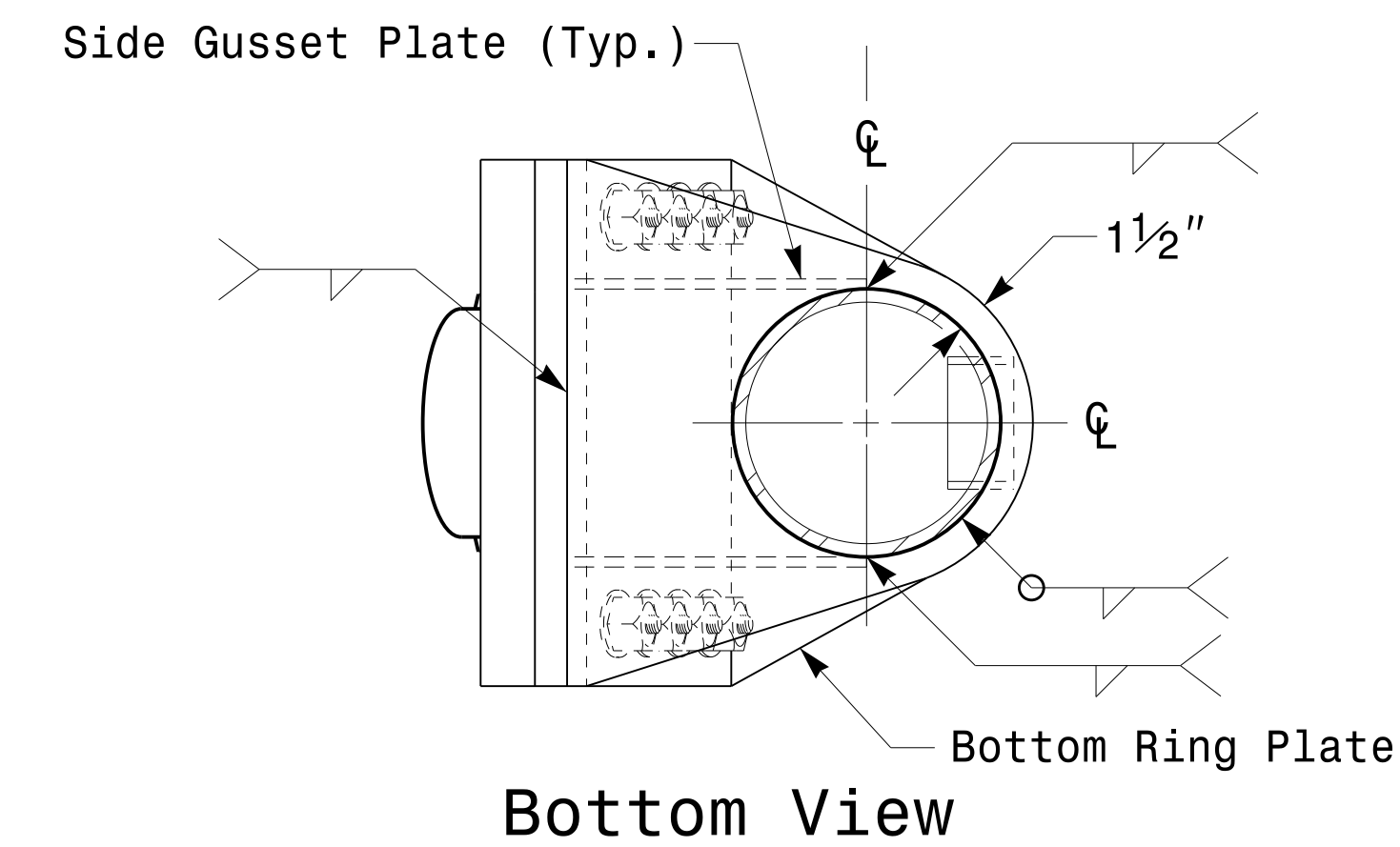
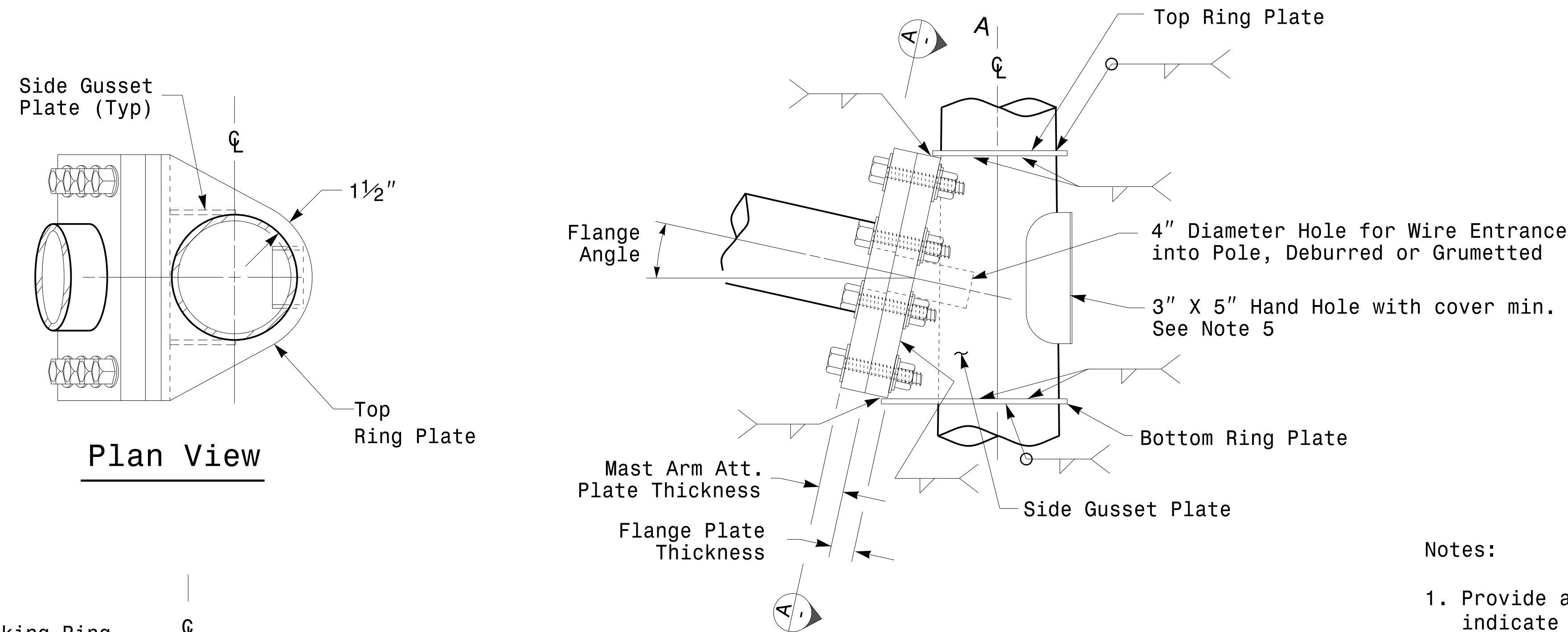

Notes:

1. Provide a permanent means of identification above the mast arm to indicate proper attachment orientation of the mast arm.
2. Designer will determine the size of all structural components, plates, fasteners, and welds shown unless they are already specified.
3. Fabricator is responsible for providing appropriate holes at drainage points to drain galvanizing materials.
4. For minimum edge distance follow AISC Table J3.4 and J3.5. For nominal bolt hole size use Table J3.3.
5. Provide upper handhole as necessary when shaft extensions are required for luminaire arms or camera. For poles without luminaires/camera, wiring can be done through the top of pole.
6. Allowable range of flange tilt angle will vary from 0° to as required.

Front Elevation View

Section A-A
Mast Arm Attachment Plate

Back Elevation View

Section B-B
Full-Penetration Groove Weld Detail

Prepared In the Offices of:

750 N. Greenfield Pkwy, Garner, NC 27529

Typical Fabrication Details For Mast Arm Connection To Pole	
PLAN DATE: OCTOBER 2017	DESIGNED BY: C.F. ANDREWS
PREPARED BY: N. BITTING	REVIEWED BY: D.C. SARKAR
REVISIONS	INIT. DATE

SEAL

Discussed by: Debesh C. Sarkar

10/11/2017
DATE

Fabrication Details - Mast Arm Connection

11-OCT-2017 08:35
P:\SSD\W\T\S\Drawings\Signal\Design Section\Eastern Region\M5\Sheets\2016\2014_Sig_M5_S1d_Connection Fabrication Detail\Mast Arm Poles.dgn
D.C. SARKAR