

Note:
 1. Opening in pole base plate shall be equal to pole base inside diameter minus 3 1/2" but shall not be less than 8 1/2".

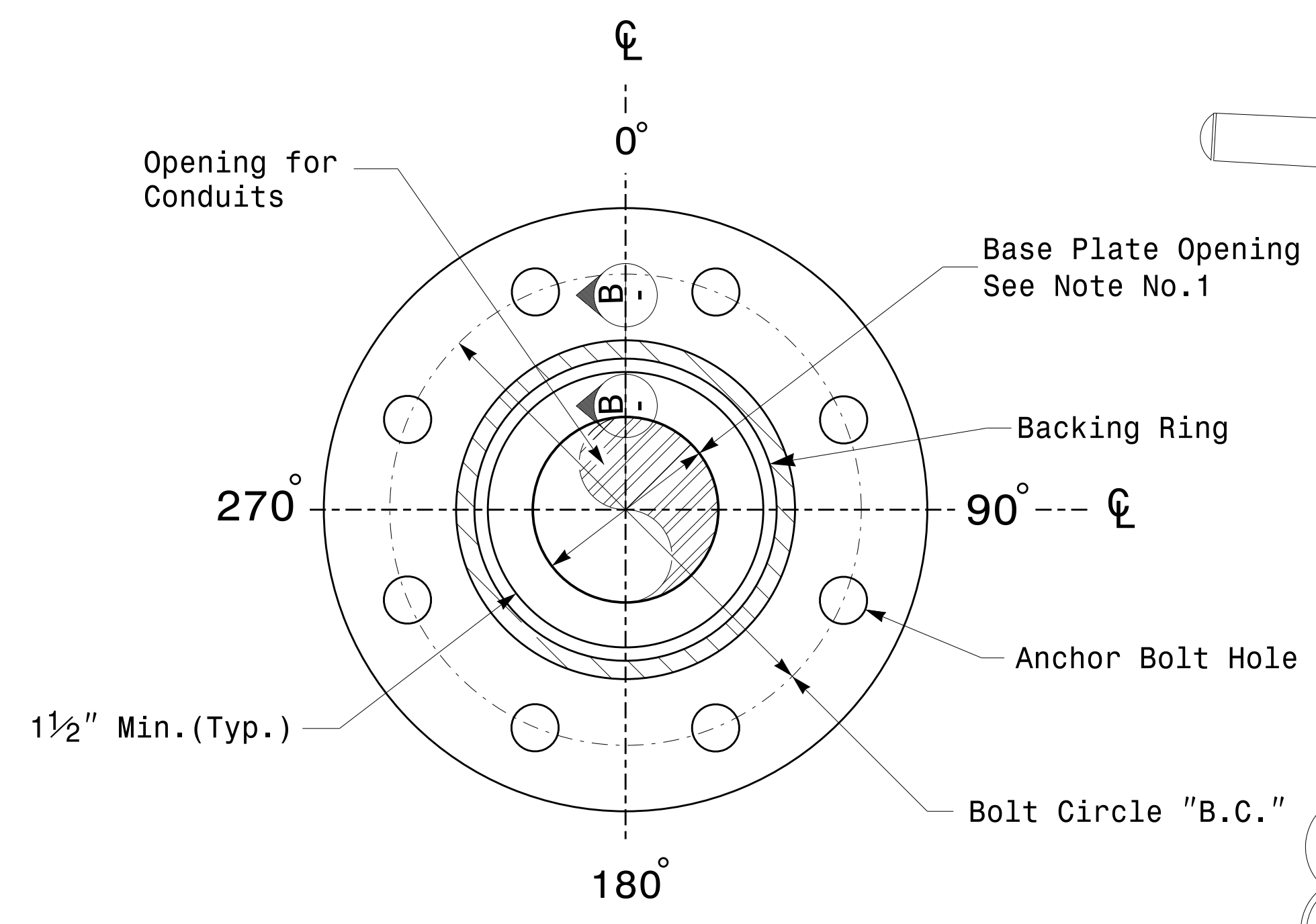

Section A-A
Pole Base Plate Details

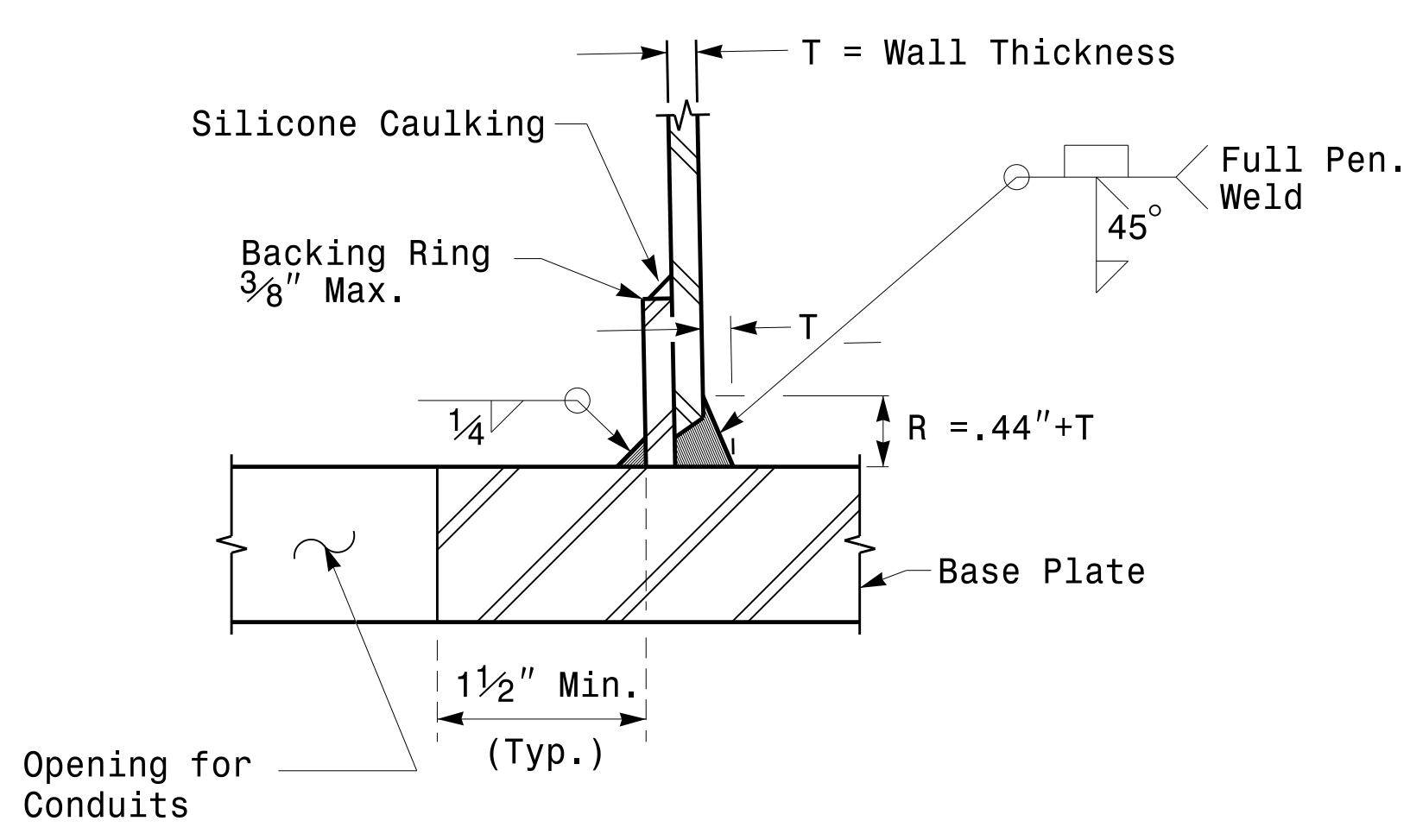

Section B-B
 (Pole Attachment to Base Plate)
Full-Penetration Groove Weld Detail

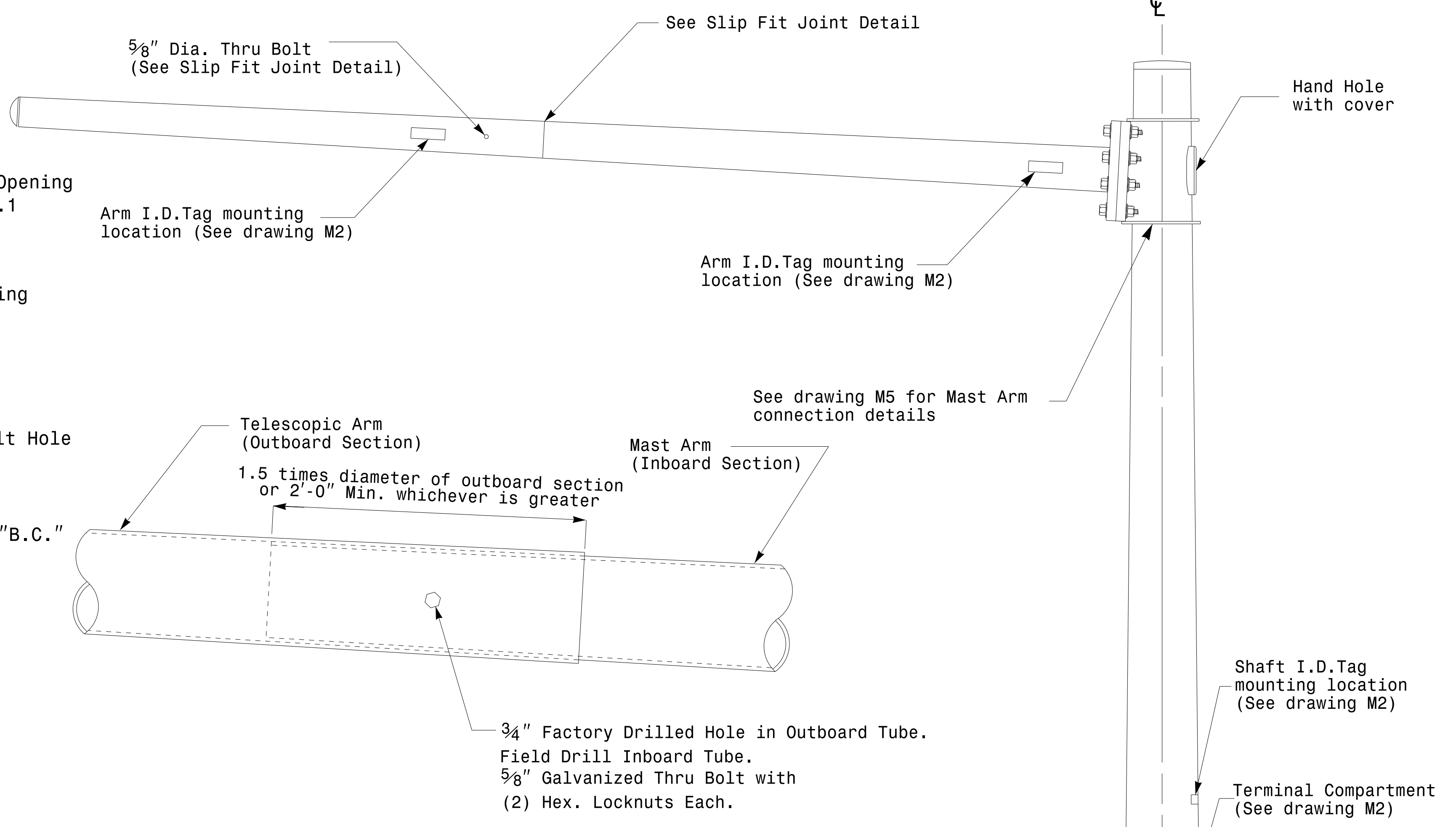

Slip Fit Joint Detail for Mast Arm

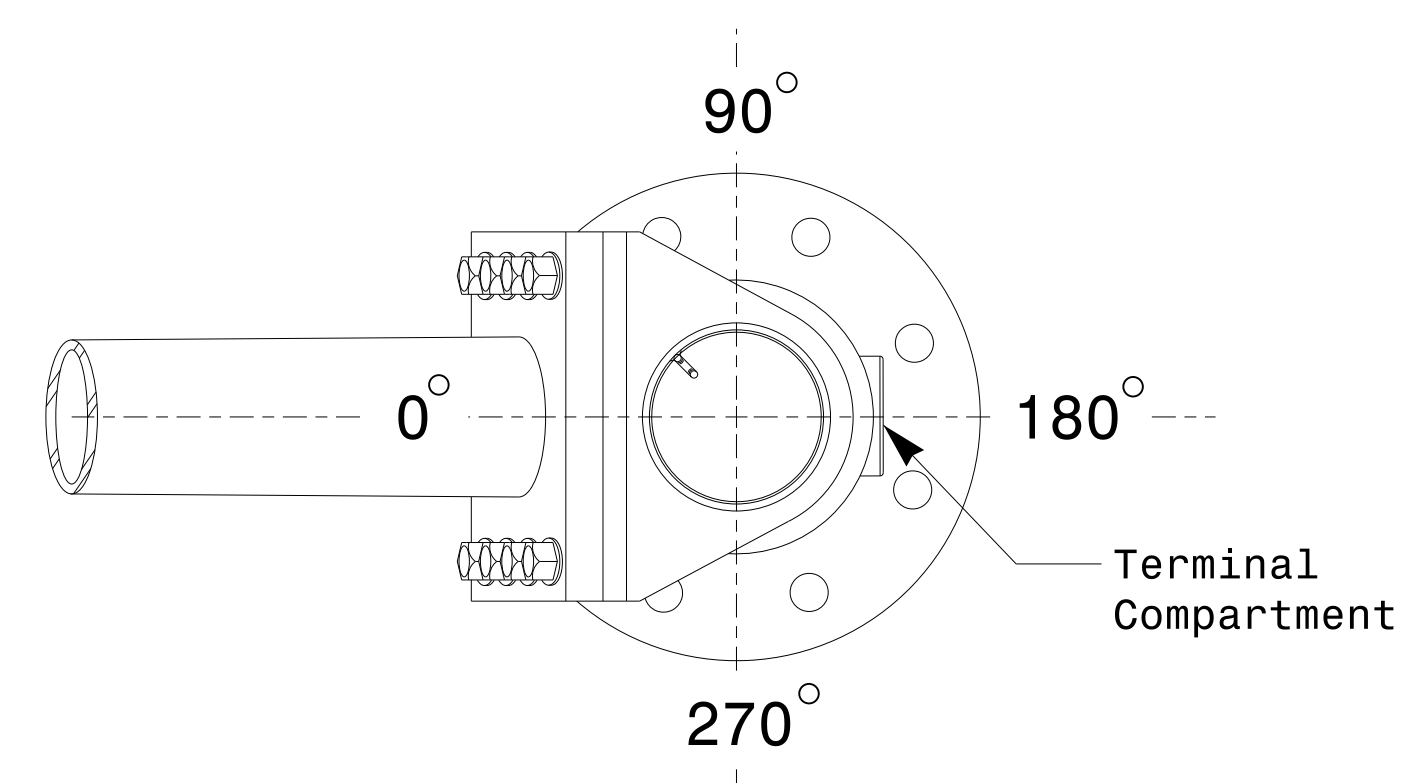

Mast Arm Radial Orientation

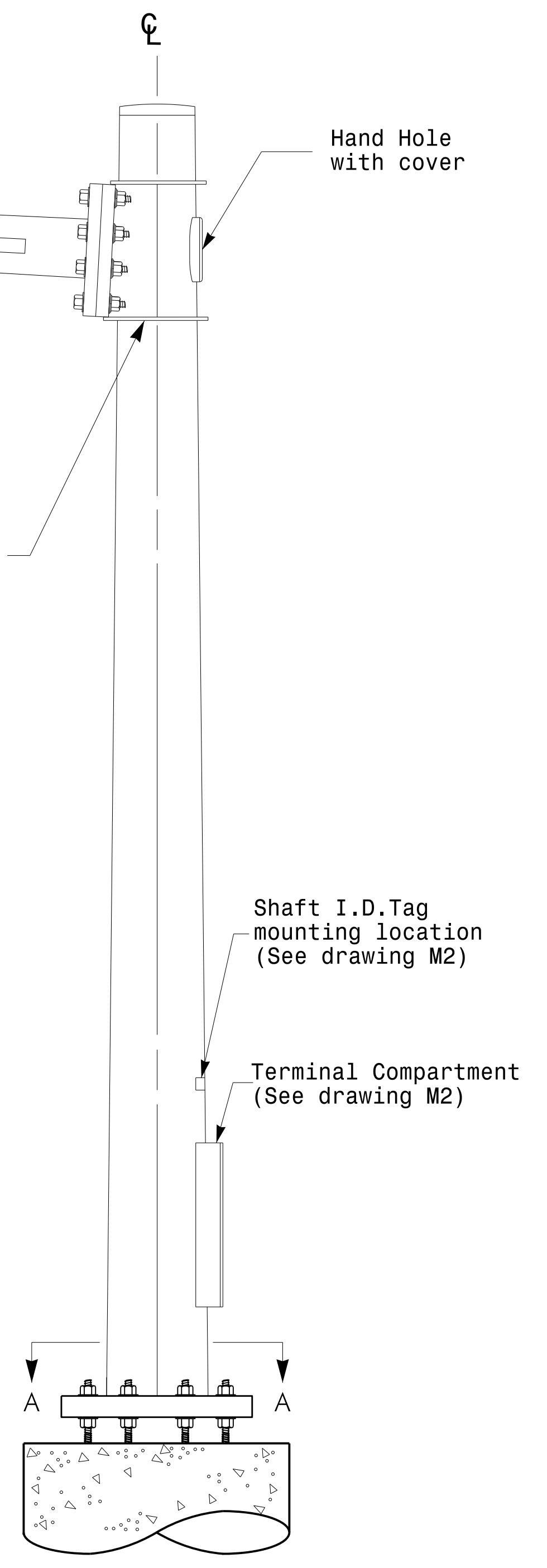

Mast Arm Pole

Fabrication Details - Mast Arm Poles

11-OCT-2017 08:33 136504115 510015451gncl Design Section Eastern RegionM4 Sheets20162014 Sig.M4 Std. Fabrication Detail-Mast Arm Poles.dgn

| | | | |
|------------------|--|---|----------|
| | Typical Fabrication Details For Mast Arm Poles | | SEAL |
| | PLAN DATE: OCTOBER 2017 PREPARED BY: N. BITTING | DESIGNED BY: K.C. DURIGON REVIEWED BY: D.C. SARKAR | |
| SCALE: 0 NA NONE | DocuSigned by: DATE: 10/11/2017 | | DATE |