

NOTE: UTILIZE FABRIC INSERT INLET DEVICES IN LIEU OF ROCK INLET SEDIMENT TRAPS, TYPE-C AS DIRECTED TO AVOID IMPOUNDMENT OF RUNOFF IN ROADWAY OPEN TO TRAFFIC.

-Y12-
 PI Sta 11+71.44
 $\Delta = 130^{\circ} 24' 28.0''$ (RT)
 $D = 112^{\circ} 20' 40.8''$
 $L = 116.08'$
 $T = 110.39'$
 $R = 51.00'$
 SE = EXIST

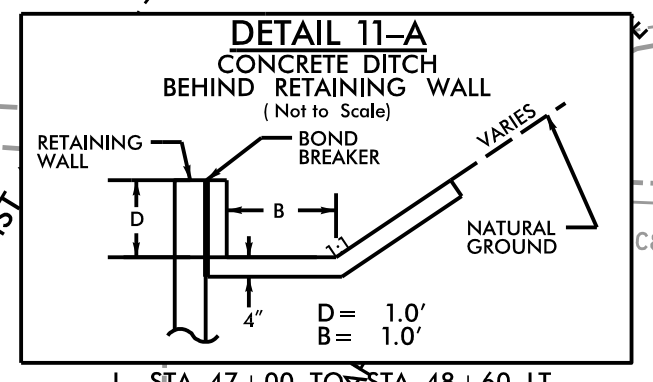

MATCHLINE -L- STA. 45+90 SEE SHEET 10

MATCHLINE -L- STA. 51+50 SEE SHEET 12

FOR -L- PROFILE SEE SHT.26
 FOR -Y11- PROFILE SEE SHT.29
 FOR -Y13- PROFILE SEE SHT.29

3/10/2023 R:\Environmental\Design\U5839-EC-32-Final.dgn

