

NOTE: PLACE TEMPORARY ROCK SEDIMENT DAMS TYPE - B AND TEMPORARY ROCK SILT CHECKS TYPE - A AT DRAINAGE OUTLETS.

NOTE: UTILIZE FABRIC INSERT INLET DEVICES IN LIEU OF ROCK INLET SEDIMENT TRAPS, TYPE-C AS DIRECTED TO AVOID IMPOUNDMENT OF RUNOFF IN ROADWAY OPEN TO TRAFFIC.

CLEARING AND GRUBBING EROSION CONTROL FOR CONSTRUCTION SHEET 11

-Y12-
 PI Sta 11+71.44
 $\Delta \cdot 130^{\circ} 24' 28.0" (RT)$
 $D \cdot 112' 20' 40.8"$
 $L \cdot 116.08'$
 $T \cdot 110.39'$
 $R \cdot 51.00'$
 SE - EXIST

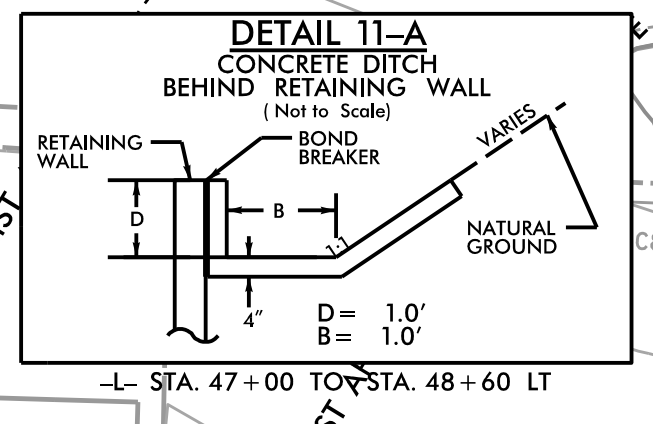

MATCHLINE -L- STA. 45+90 SEE SHEET 10

MATCHLINE -L- STA. 51+50 SEE SHEET 12

FOR -L- PROFILE SEE SHT.26
 FOR -Y11- PROFILE SEE SHT.29
 FOR -Y13- PROFILE SEE SHT.29

MATCHLINE -Y13-
 STA. 11+40 SEE SHEET 21

3/10/2023 R:\Environmental\Design\U5839-EC-11-C&G.dgn
 8/17/99
 REVISIONS

