

SUPERSTRUCTURE BILL OF MATERIAL	
SPAN A	(CU. YDS.)
POUR #1	162
POUR #2	25
POUR #3	58
POUR #4	6
POUR #5	19
TOTALS**	270

** QUANTITIES FOR BARRIER RAILS ARE NOT INCLUDED

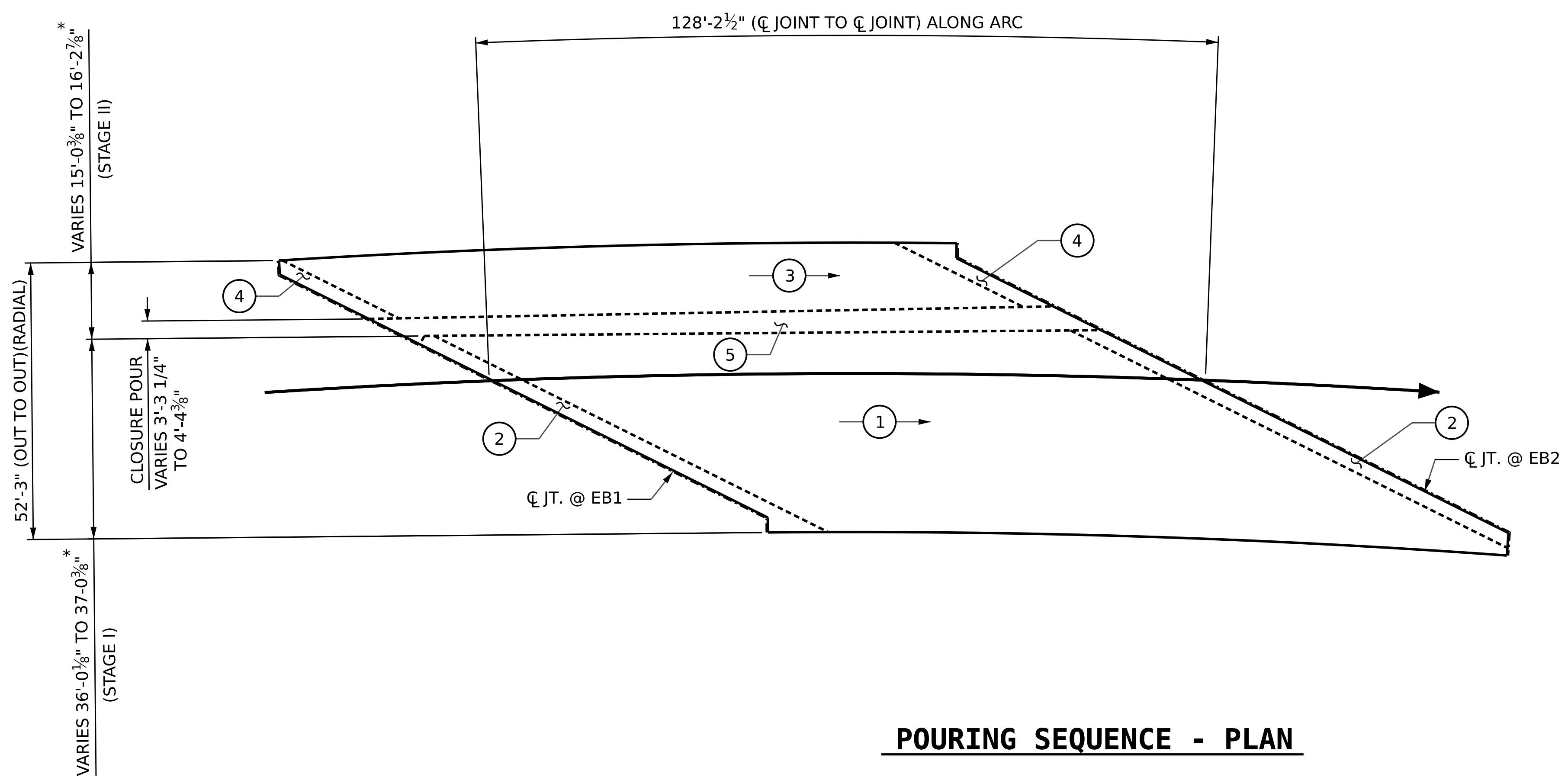

(POUR #2 CANNOT BE STARTED UNTIL ADJACENT POUR LABELED POUR #1 REACHES A MINIMUM OF 3000 PSI.)

① → INDICATES POUR DIRECTION AND NUMBER

GROOVING BRIDGE FLOORS	
APPROACH SLABS	2,203 SQ. FT.
BRIDGE DECK	5,911 SQ. FT.
TOTAL	8,114 SQ. FT.

PROJECT NO. B-3186 / B-5898
HAYWOOD COUNTY
 STATION: 32+21.34 -L_ LT-
 SHEET 1 OF 2

AECOM
AECOM TECHNICAL SERVICES OF NC, INC.
 5430 WADE PARK BOULEVARD, SUITE 200
 RALEIGH, NC 27607
 (919) 854-6200 www.aecom.com
 AECOM License No. F0242

PROFESSIONAL SEAL
 GREGORY R. COLS
 ENGINEER
 041343
 10/18/2023

STATE OF NORTH CAROLINA DEPARTMENT OF TRANSPORTATION RALEIGH					
BILL OF MATERIALS					
REVISIONS					SHEET NO.
NO.	BY:	DATE:	NO.	BY:	DATE:
1			3		
2			4		
					S1-26
					TOTAL SHEETS 43

DRAWN BY :	A. K. VASUDEVAN	DATE :	03/2023
CHECKED BY :	S. NATARAJAN	DATE :	03/2023
DESIGN ENGINEER OF RECORD:	G.R. COLS	DATE :	03/2023

DOCUMENT NOT CONSIDERED
 FINAL UNLESS ALL
 SIGNATURES COMPLETED