

FROM STA. 6+45 TO STA. 6+90 LT -L LT-  
FROM STA. 6+90 TO STA. 7+24 LT -L LT-

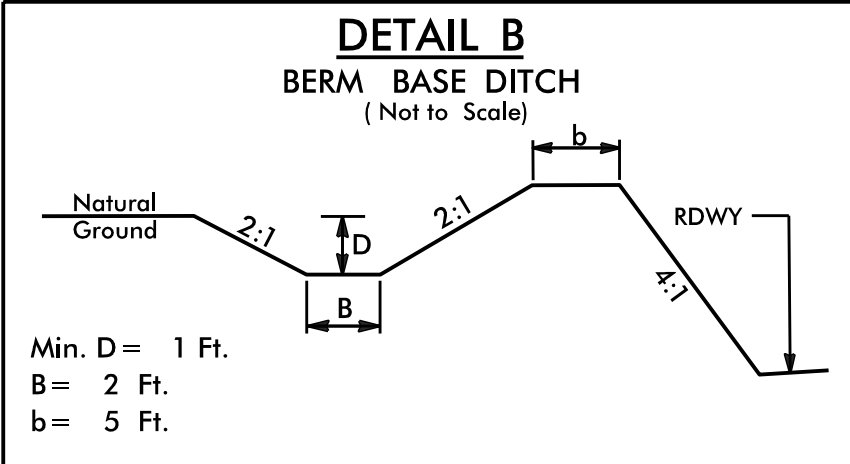

FROM STA. 8+80 TO STA. 9+25 LT -L LT-  
FROM STA. 9+25 TO STA. 9+78 LT -L LT-

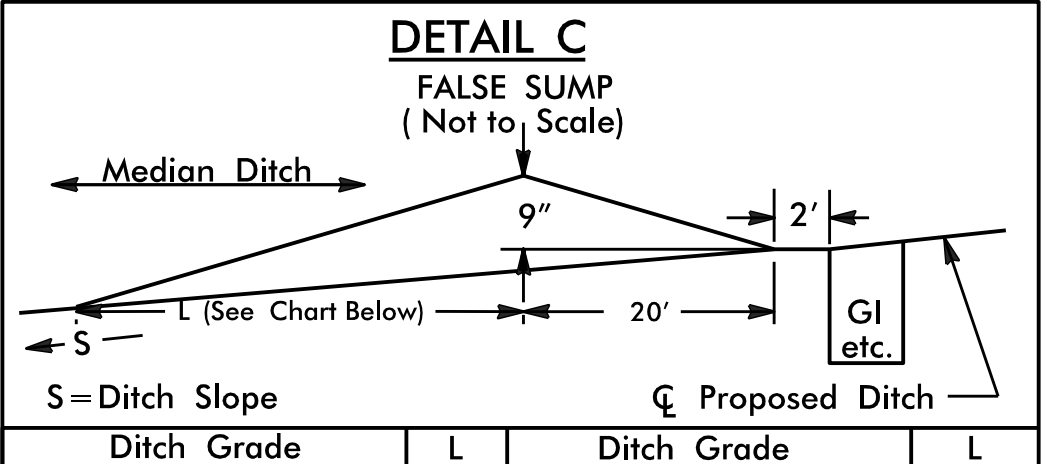

FROM STA. 8+33 TO STA. 8+51 M -L LT-  
FROM STA. 11+74 TO STA. 11+92 M -L LT-  
FROM STA. 17+02 TO STA. 17+19 M -L LT-  
FROM STA. 29+47 TO STA. 29+65 M -L LT-  
FROM STA. 37+38 TO STA. 37+56 M -L LT-

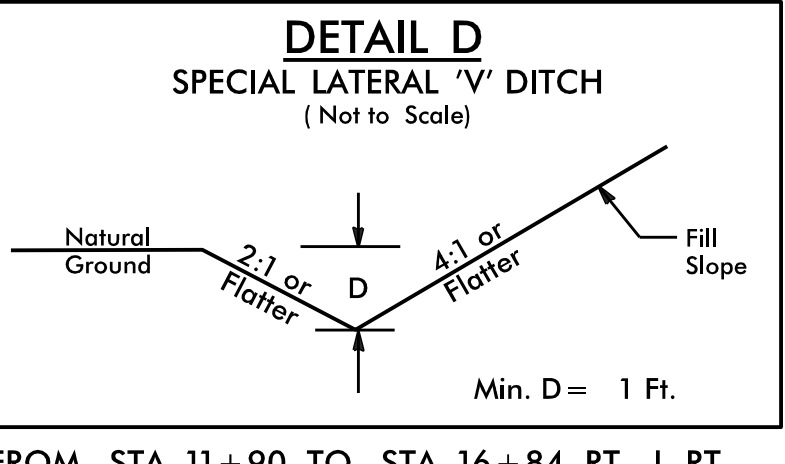

FROM STA. 11+90 TO STA. 16+84 RT -L RT-

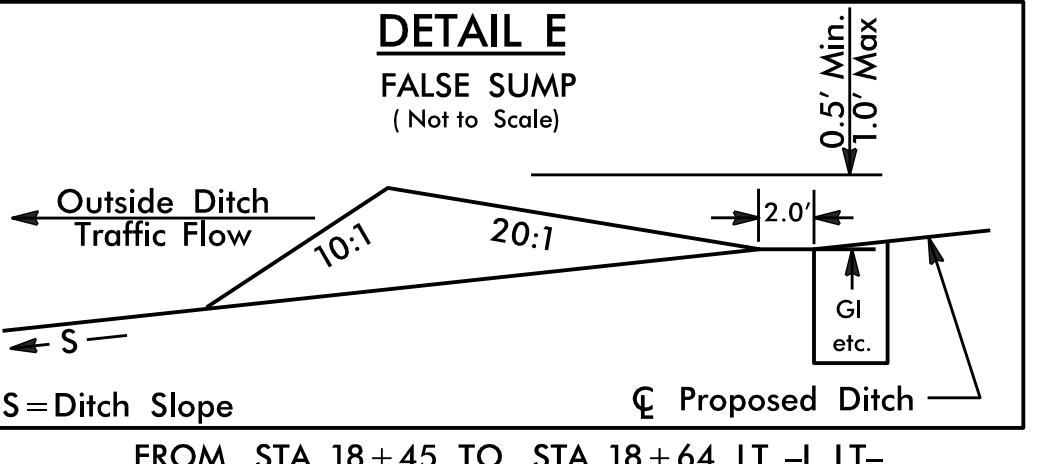

FROM STA. 18+45 TO STA. 18+64 LT -L LT-  
FROM STA. 22+55 TO STA. 22+73 LT -L LT-

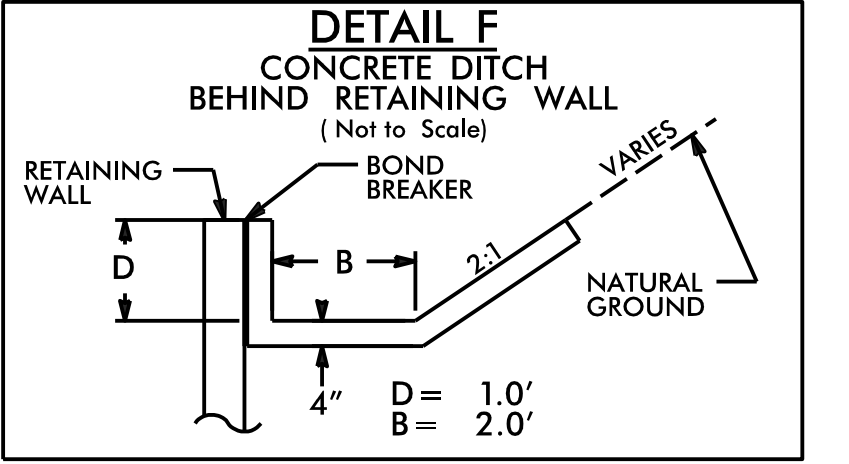

FROM STA. 9+60 TO STA. 10+25 LT -L LT-  
FROM STA. 10+25 TO STA. 11+60 LT -L LT-  
FROM STA. 12+05 TO STA. 12+47 LT -L LT-  
FROM STA. 12+47 TO STA. 16+49 LT -L LT-  
FROM STA. 11+90 TO STA. 12+63 RT -L RT-  
FROM STA. 12+63 TO STA. 13+60 RT -L RT-  
FROM STA. 13+60 TO STA. 14+08 RT -L RT-  
FROM STA. 14+08 TO STA. 16+77 RT -L RT-  
FROM STA. 18+64 TO STA. 19+54 LT -Y1 RT-  
FROM STA. 22+09 TO STA. 23+83 LT -Y1 RT-  
FROM STA. 20+54 TO STA. 20+68 LT -Y1 RT-

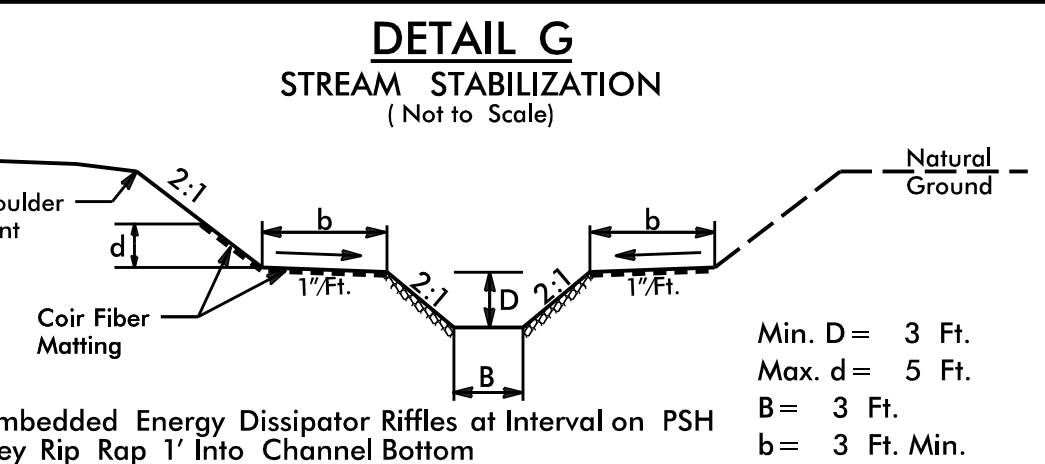

FROM STA. 24+87 TO STA. 30+50 -L RT  
EST. 404 TONS CLASS I RIPRAP; 1,375 SY COIR FIBER MATTING

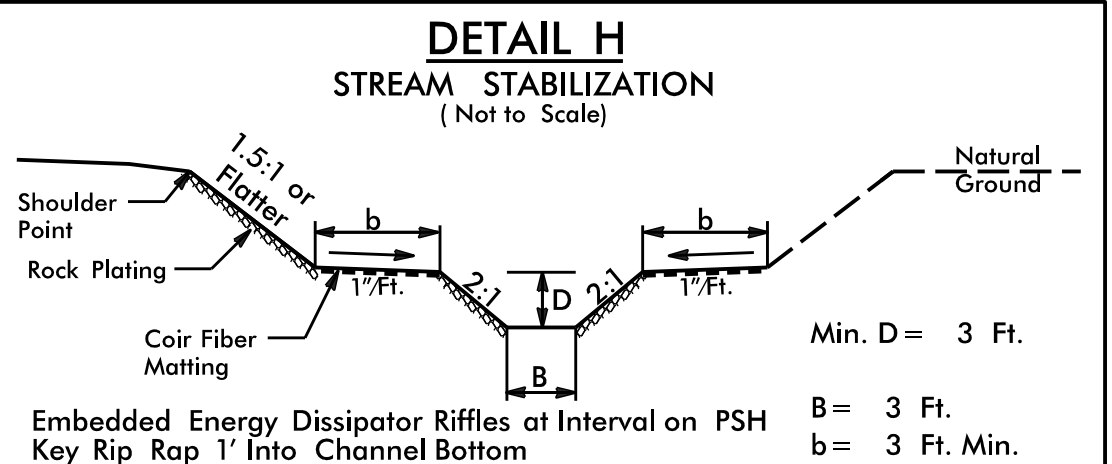

FROM STA. 30+50 TO STA. 31+50 -L RT  
EST. 318 TONS CLASS I RIPRAP; 195 SY COIR FIBER MATTING  
SEE ROCK PLATING DETAIL ON SHEET 2G-1

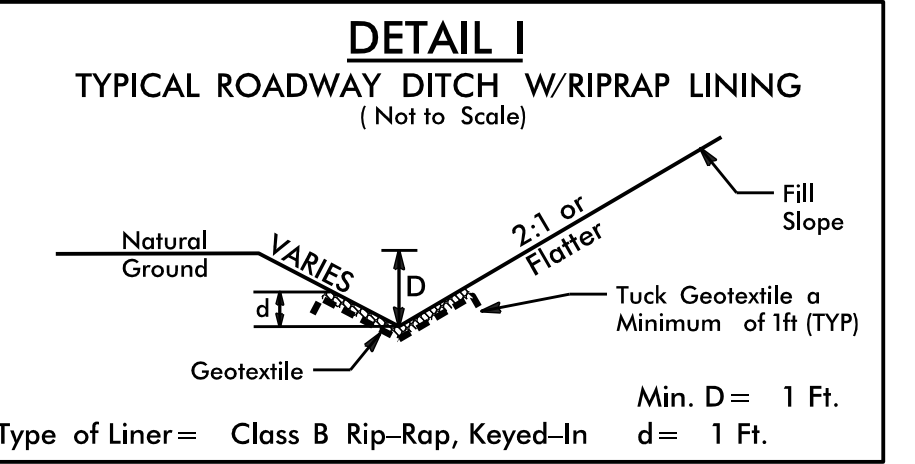

FROM STA. 17+01 TO STA. 17+47 LT -L LT-

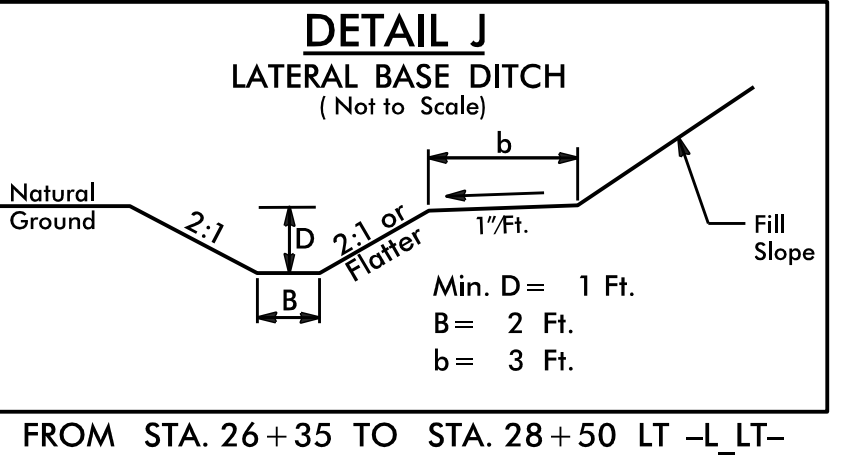

FROM STA. 26+35 TO STA. 28+50 LT -L LT-

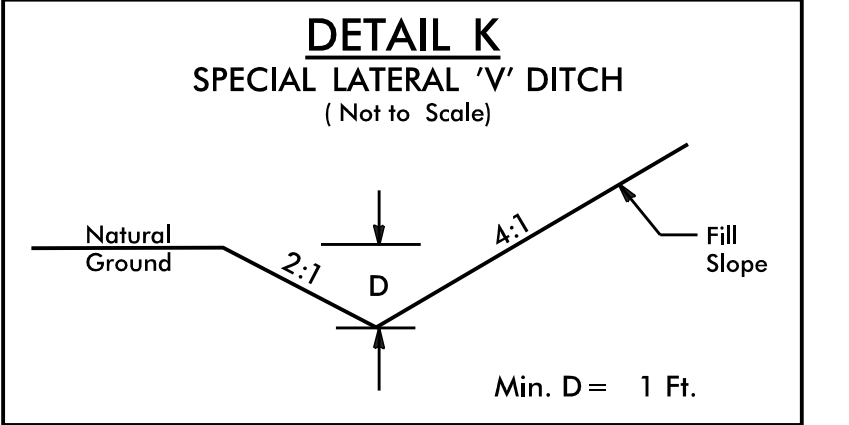

FROM STA. 16+83 TO STA. 19+45 LT -Y1 RT-  
FROM STA. 19+80 TO STA. 20+64 LT -Y1 RT-

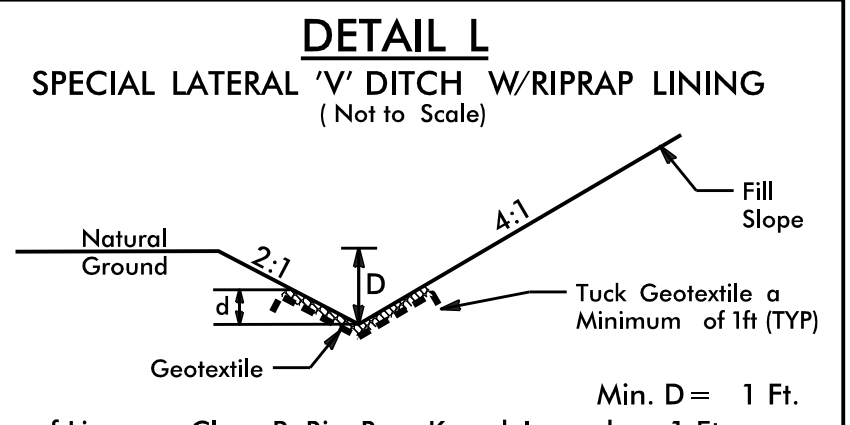

FROM STA. 19+45 TO STA. 19+80 LT -Y1 RT-

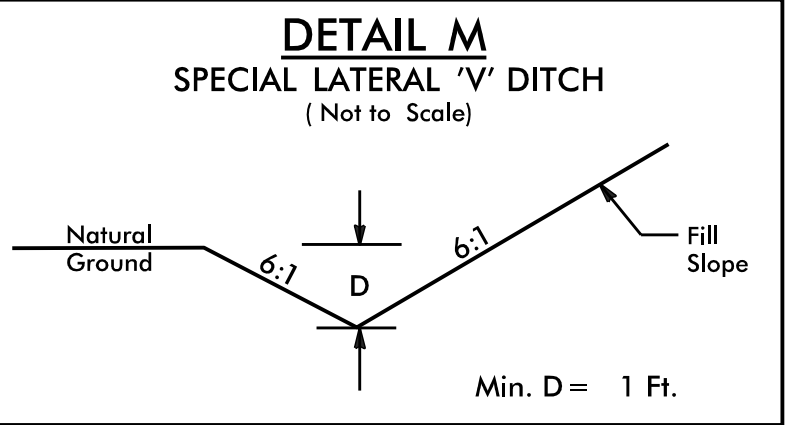

FROM STA. 16+84 TO STA. 17+09 RT -L RT-

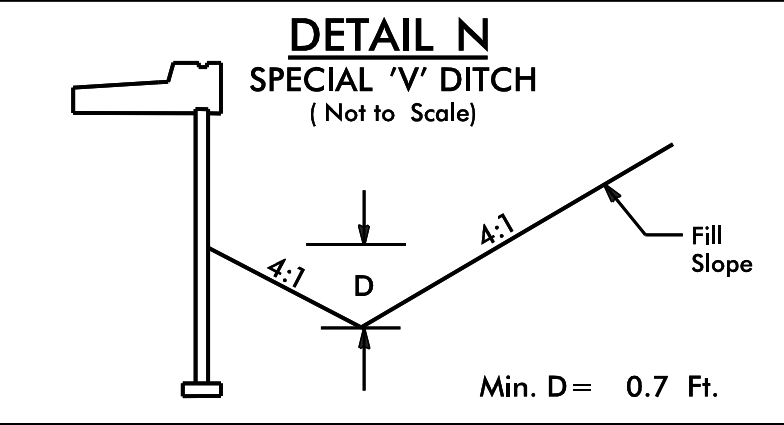

FROM STA. 28+75 TO STA. 29+50 M -L RT-

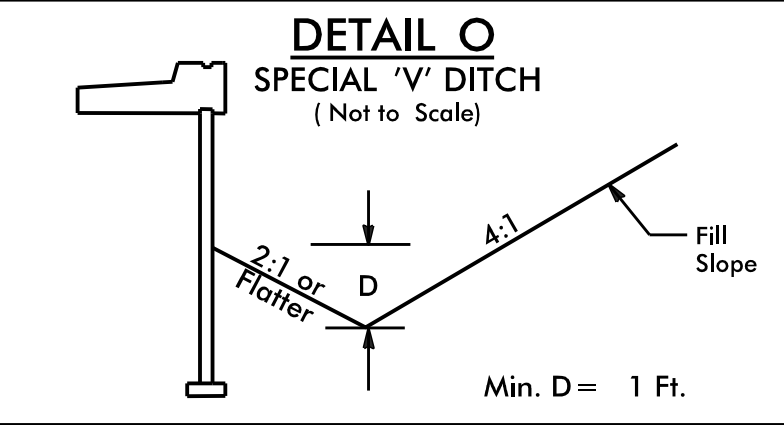

FROM STA. 29+65 TO STA. 31+98 M -L RT-

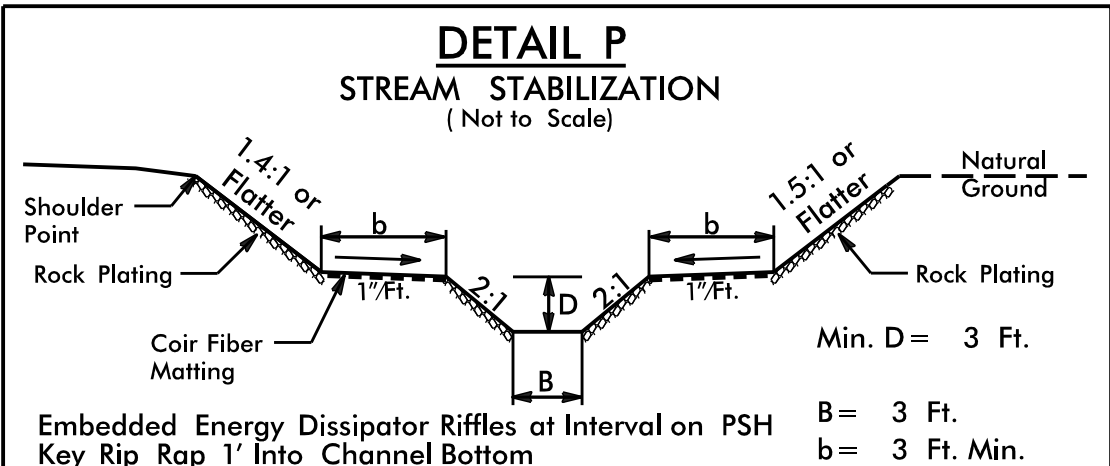

FROM STA. 31+50 TO STA. 34+77 -L RT  
EST. 1,534 TONS CLASS I RIPRAP; 360 SY COIR FIBER MATTING  
SEE ROCK PLATING DETAIL ON SHEET 2G-1

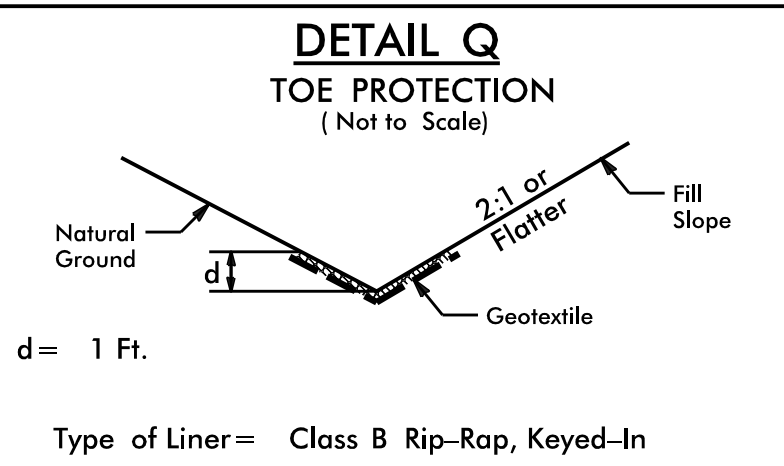

FROM STA. 17+47 TO STA. 18+40 LT -L LT-  
FROM STA. 18+78 TO STA. 22+50 LT -L LT-  
FROM STA. 16+91 TO STA. 18+65 RT -Y1 RT-

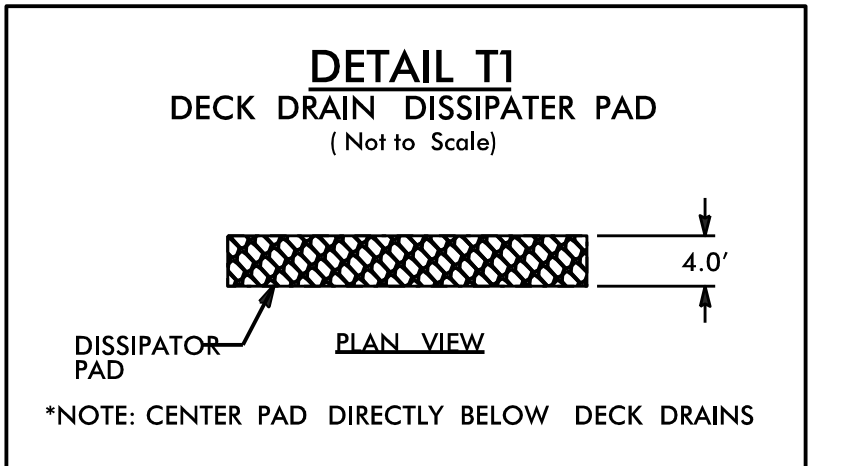

FROM STA. 22+25 TO STA. 23+35 RT -DET01EB-  
FROM STA. 24+40 TO STA. 24+86 RT -DET01EB-  
FROM STA. 22+25 TO STA. 23+35 LT -DET01EB-  
FROM STA. 24+70 TO STA. 25+45 LT -DET01EB-

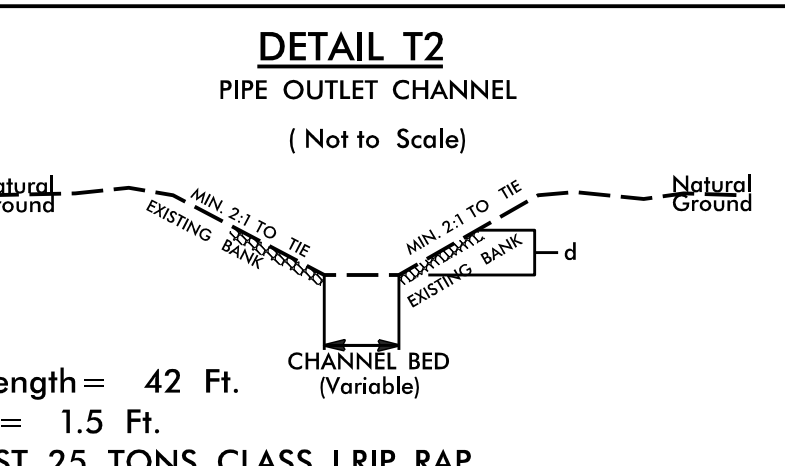

FROM STA. 24+86 TO STA. 25+28 RT -DET01EB-

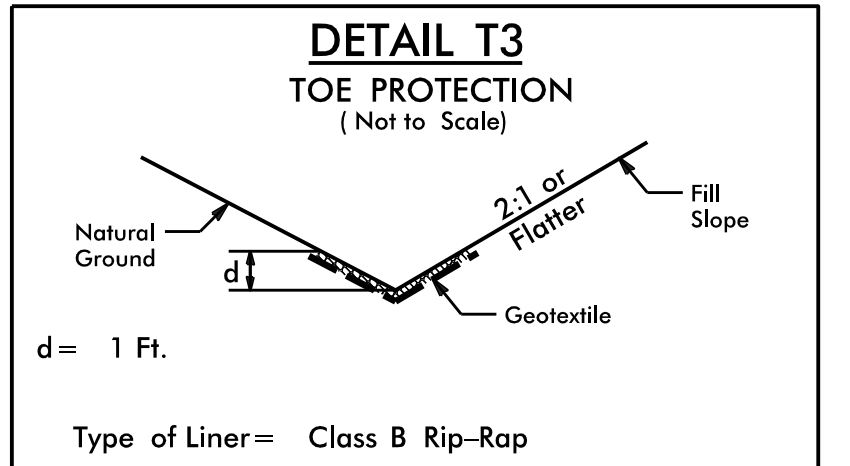

FROM STA. 26+50 TO STA. 28+00 RT -DET01EB-  
FROM STA. 28+00 TO STA. 32+00 RT -DET01EB-

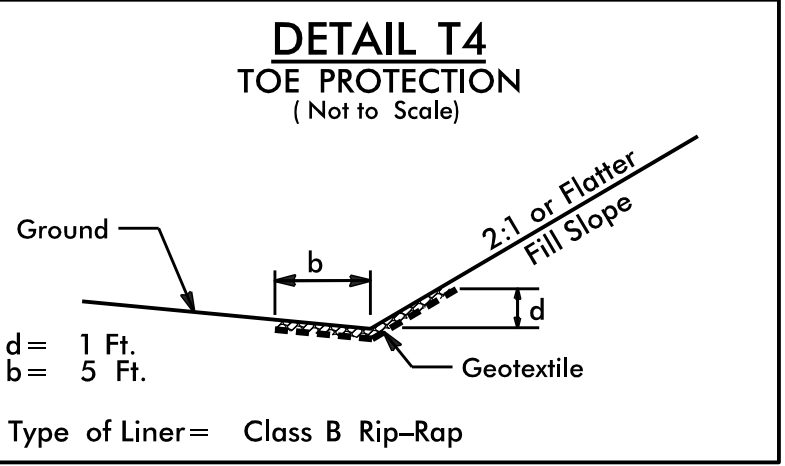

FROM STA. 26+50 TO STA. 29+39 RT -DET01EB-

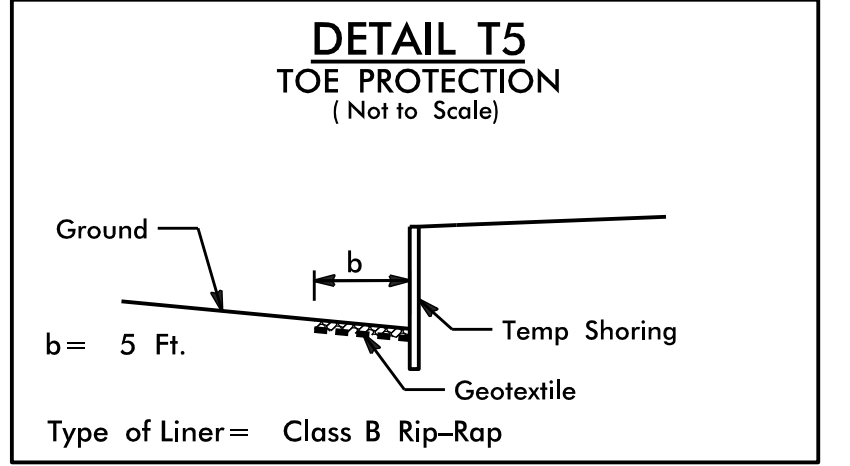

FROM STA. 19+75 TO STA. 23+22 LT -DET01EB-  
FROM STA. 21+95 TO STA. 22+32 RT -DET01EB-  
FROM STA. 25+30 TO STA. 26+50 LT -DET01EB-  
FROM STA. 25+72 TO STA. 26+87 LT -DET01WB-  
FROM STA. 29+83 TO STA. 30+01 LT -DET01WB-

REVISIONS