

## JOINT INSTALLATION PROCEDURE:

1. INSTALL THE STRIP SEAL EXPANSION JOINT AS RECOMMENDED BY THE MANUFACTURER.
2. A MANUFACTURER'S REPRESENTATIVE SHALL BE PRESENT DURING INSTALLATION OF THE JOINT.
3. PLACE STEEL RETAINER RAILS IN JOINT OPENING. PROPERLY ALIGN THE RAILS BOTH HORIZONTALLY AND VERTICALLY. DO NOT WELD SUPPORT SYSTEM TO THE METALLIZED SURFACES OF THE STEEL RETAINER RAILS.
4. CONFLICTING REINFORCING STEEL MAY BE SHIFTED SLIGHTLY WHEN NECESSARY.
5. DECK SLAB CONCRETE PLACEMENT OPERATIONS SHALL COMMENCE PER THE POURING SEQUENCE AFTER FINAL JOINT ALIGNMENT IS SET.
6. PROTECT THE STEEL RETAINER RAILS FROM BEING FOULED BY CONCRETE SPILLOVER DURING THE DECK POUR.
7. LOOSEN THE STEEL RETAINER RAIL SUPPORT SYSTEM TO ALLOW MOVEMENT WHILE CONCRETE CURES.
8. RE-LEVEL AND RE-ALIGN STEEL RETAINER RAIL AS REQUIRED ON OPPOSITE SIDE OF JOINT.
9. PLACE APPROACH/DECK SLAB CONCRETE.
10. ONCE THE CONCRETE HAS HARDENED SUFFICIENTLY ON BOTH SIDES OF JOINT, STEEL RETAINER RAILS SHALL BE CLEANED THOROUGHLY AND SEAL CHANNELS SHALL BE INSPECTED TO ASCERTAIN THE ABSENCE OF CONCRETE AND DEBRIS.
11. COAT THE STRIP SEAL LUGS WITH LUBRICANT-ADHESIVE AND INSTALL THE NEOPRENE STRIP SEAL GLAND AS RECOMMENDED BY THE STRIP SEAL EXPANSION JOINT MANUFACTURER.

## GENERAL NOTES

FOR STRIP SEAL EXPANSION JOINTS, SEE SPECIAL PROVISIONS.

STEEL RETAINER RAILS AND COVER PLATES SHALL CONFORM TO AASHTO M270 GRADE 36 OR GRADE 50 STEEL. ALL STUD ANCHORS SHALL CONFORM TO AASHTO M169, GRADES 1010 THRU 1020 OR APPROVED EQUAL. ALL CONCRETE INSERTS SHALL BE CLOSED END AND SHALL CONFORM TO AASHTO M169, GRADE 12L14. TENSILE CAPACITY SHALL BE 3000 LBS. MIN.

ONLY STEEL RETAINER RAILS OF ONE-PIECE CONSTRUCTION ARE PERMITTED. STEEL RETAINER RAILS CONSISTING OF TWO OR MORE COMPONENTS WELDED TOGETHER TO OBTAIN THEIR FINAL CROSS-SECTIONAL SHAPE ARE NOT PERMITTED.

STUD ANCHORS SHALL BE SHOP WELDED AND SHALL BE ELECTRIC ARC END WELDED WITH COMPLETE FUSION.

SURFACES COMING IN CONTACT WITH STRIP SEAL GLAND SHALL BE GROUND SMOOTH PRIOR TO METALLIZING.

UPON COMPLETION OF SHOP FABRICATION, THE STEEL RETAINER RAILS SHALL BE METALLIZED AS SHOWN IN THE "METALLIZING DETAIL". SEE SPECIAL PROVISIONS FOR THERMAL SPRAYED COATINGS (METALLIZATION).

INSTALLED STEEL RETAINER RAILS SHALL FOLLOW THE ROADWAY SLOPE.

FIELD SPLICES OF THE RETAINER RAILS SHALL BE KEPT TO A MINIMUM. CONTRACTOR SHALL FURNISH DETAILED PLANS SHOWING PROPOSED SPLICE LOCATIONS FOR APPROVAL. FINISHED WELDS SHALL BE REPAIRED IN ACCORDANCE WITH THE SPECIAL PROVISION FOR THERMAL SPRAYED COATINGS (METALLIZATION).

NEOPRENE STRIP SEAL GLAND SHALL BE CONTINUOUS THROUGHOUT THE JOINT AND SHALL BE COMPATIBLE WITH THE STEEL RETAINER RAILS. FIELD SPLICING THE GLAND IS NOT PERMITTED.

NO ALTERNATE JOINT DETAILS SHALL BE PERMITTED IN LIEU OF THOSE SHOWN ON THESE PLANS.

THE COVER PLATES SHALL BE GALVANIZED OR METALLIZED IN ACCORDANCE WITH THE STANDARD SPECIFICATIONS. FOR THERMAL SPRAYED COATINGS (METALLIZATION), SEE SPECIAL PROVISIONS.

THE CONTRACTOR MAY, AT HIS OPTION, USE ADHESIVELY ANCHORED ANCHOR BOLTS IN PLACE OF CONCRETE INSERTS FOR COVER PLATES. THE YIELD LOAD OF THE 3/4" Ø BOLT IS 10 KIPS. FIELD TESTING OF THE ADHESIVE BONDING SYSTEM IS NOT REQUIRED.

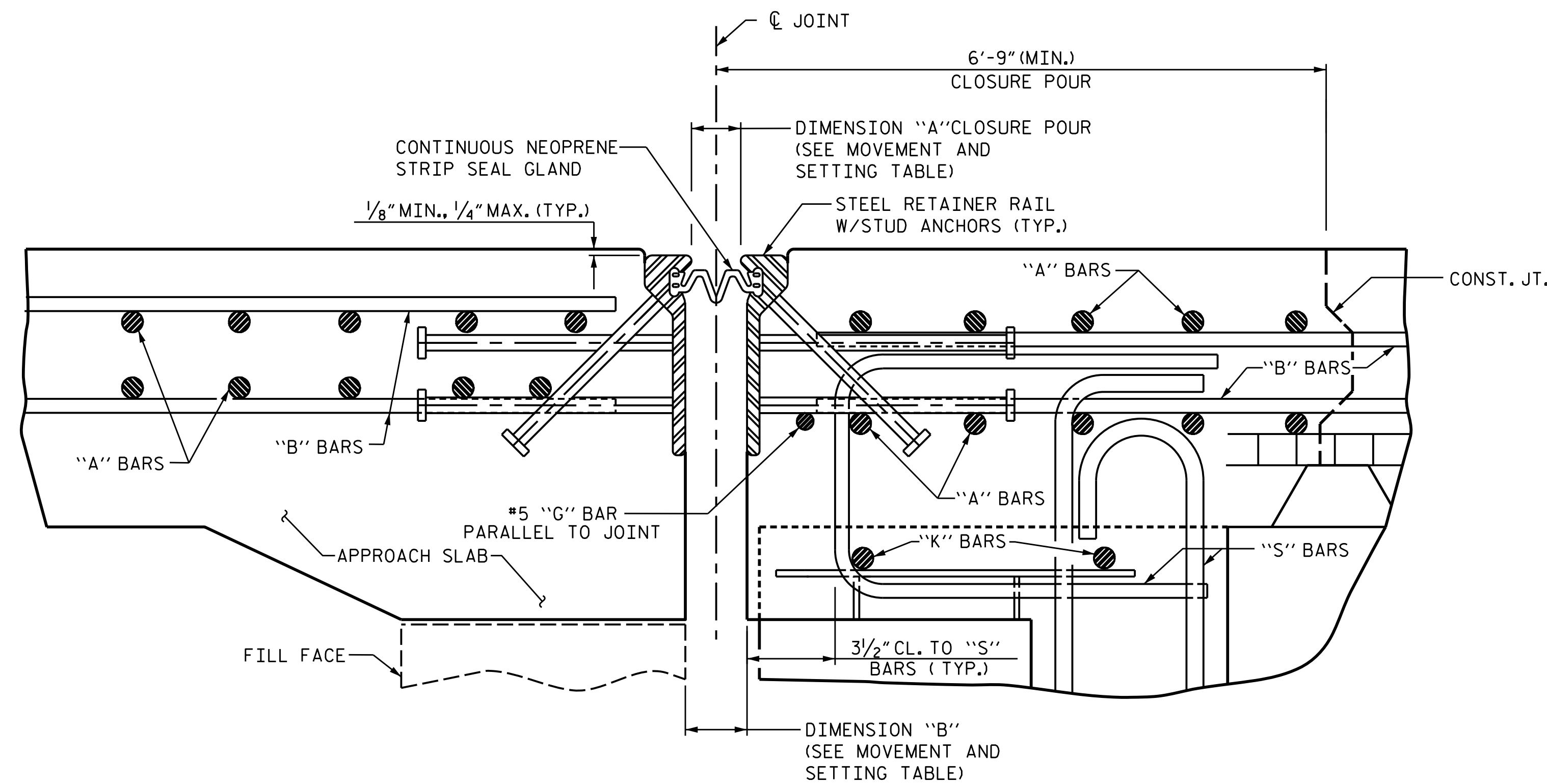

### STRIP SEAL EXPANSION JOINT DETAILS

SECTION NORMAL TO JOINT -- PRESTRESSED GIRDER SUPERSTRUCTURE

LOCATION	SKEW ANGLE	TOTAL MOVEMENT (ALONG C RDWY)	MOVEMENT AND SETTING AT JOINT					
			DIMENSION "A"			DIMENSION "B"		
			PERPENDICULAR JOINT OPENING AT 45° F	PERPENDICULAR JOINT OPENING AT 60° F	PERPENDICULAR JOINT OPENING AT 90° F	PERPENDICULAR JOINT OPENING AT 45° F	PERPENDICULAR JOINT OPENING AT 60° F	PERPENDICULAR JOINT OPENING AT 90° F
END BENT 1	33°-57'-31.6"	7/8"	2 1/4"	2"	1 13/16"	2 3/16"	2 1/2"	2 5/16"
END BENT 2	33°-57'-31.6"	1 3/16"	2 1/4"	2"	1 13/16"	2 3/16"	2 1/2"	2 5/16"

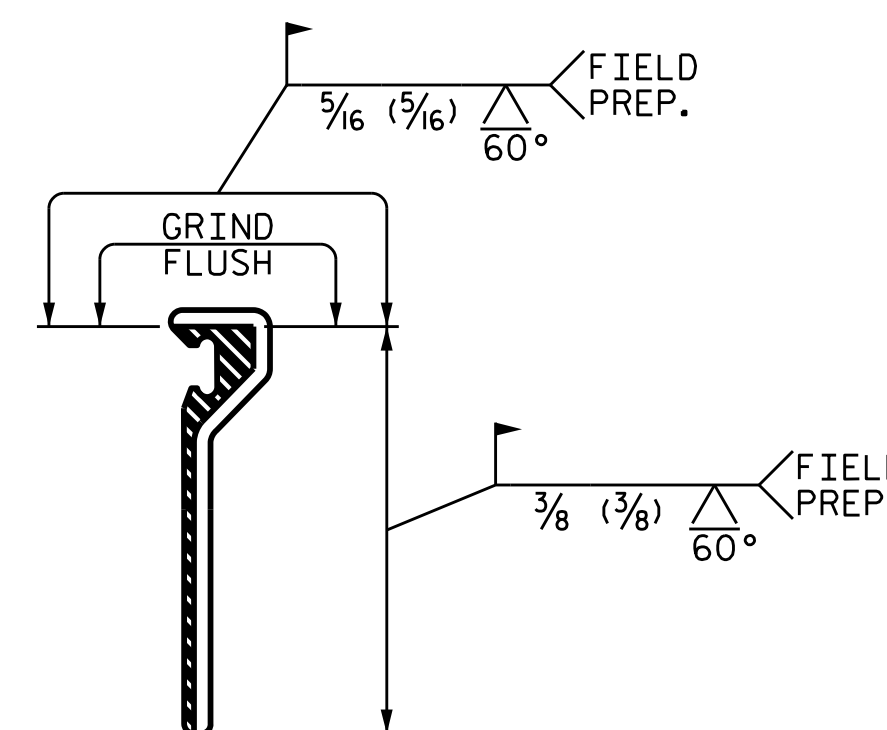

### STEEL RETAINER RAIL (FIELD SPLICE DETAIL)

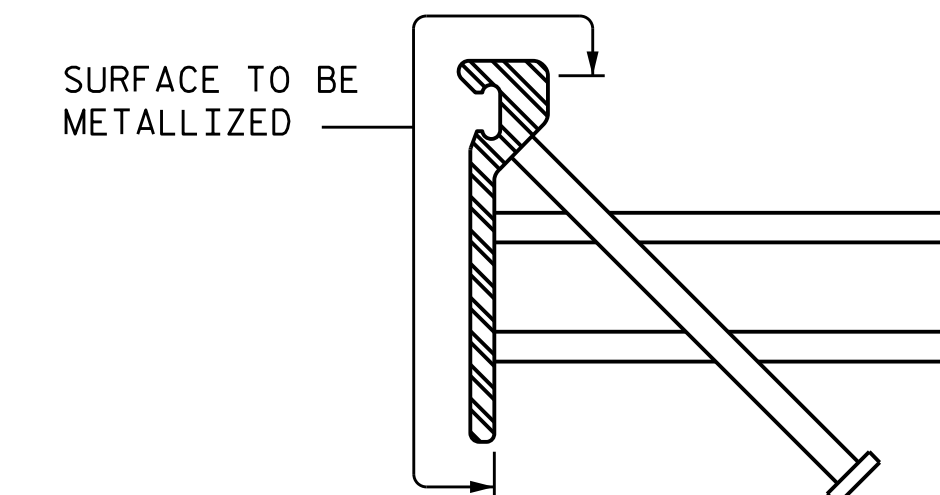

### METALLIZING DETAIL

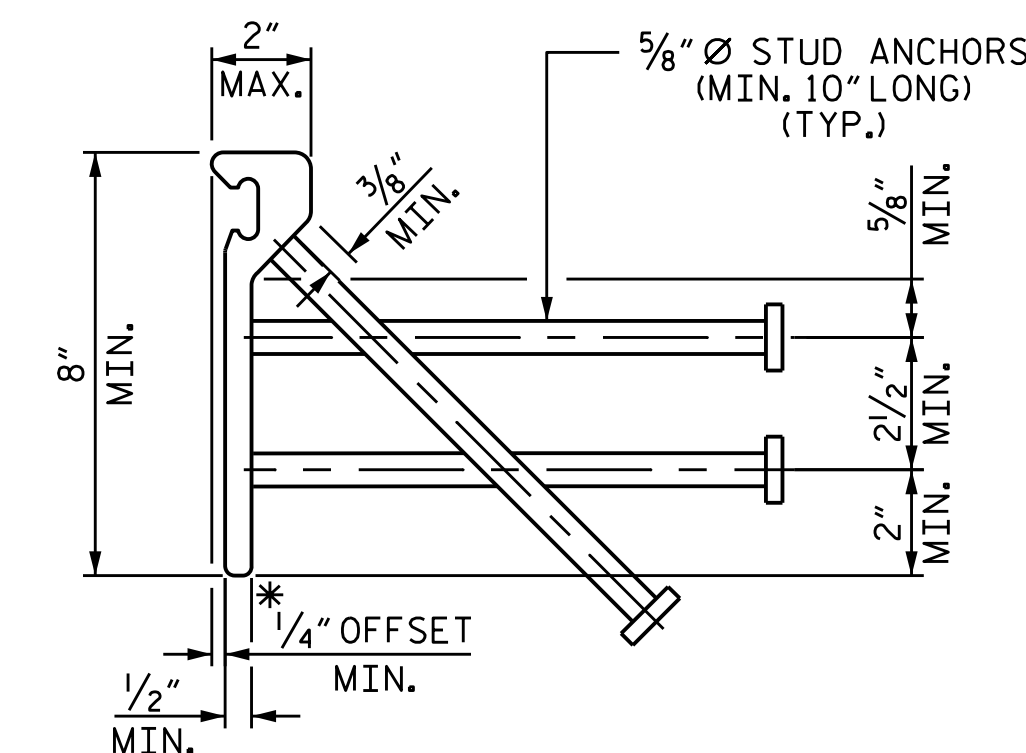

### TYPICAL SECTION STEEL RETAINER RAIL

\*DIMENSION "B" BASED ON STEEL RETAINER RAIL TOP OFFSET TO FACE OF RAIL OF 1/4" MINIMUM. IF ACTUAL OFFSET IS GREATER ADJUST DIMENSION "B" AS REQUIRED.

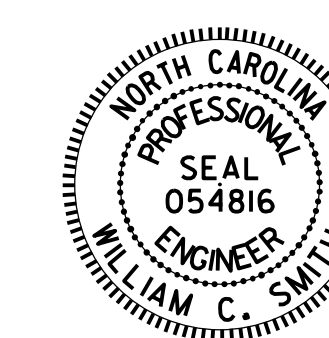

DocuSigned by:  
William C. Smith  
0A2A8293F0241D  
10/24/2023

PROJECT NO. B-5981  
DUPLIN COUNTY  
STATION: 23+56.64 -L-

SHEET 1 OF 2

STATE OF NORTH CAROLINA  
DEPARTMENT OF TRANSPORTATION  
RALEIGH  
STANDARD  
STRIP SEAL EXPANSION JOINT DETAILS

DESIGN ENGINEER OF RECORD:  
W. C. SMITH DATE: 3/8/23  
ASSEMBLED BY: S. T. SANDOR DATE: 7/29/22  
CHECKED BY: M. K. BEARD DATE: 8/27/22  
DRAWN BY: MAA 6/20  
CHECKED BY: BNB 6/20

10/18/2023  
R:\Structures\Plans\300016\401.053.B5981.SMU.SSEJ.S1-27.300016.dgn  
ssandor

DOCUMENT NOT CONSIDERED FINAL UNLESS ALL SIGNATURES COMPLETED

REVISIONS						SHEET NO.
NO.	BY:	DATE:	NO.	BY:	DATE:	
1			3			S1-27
2			4			TOTAL SHEETS 43

STD. NO. SSEJ1(SHT 1)