

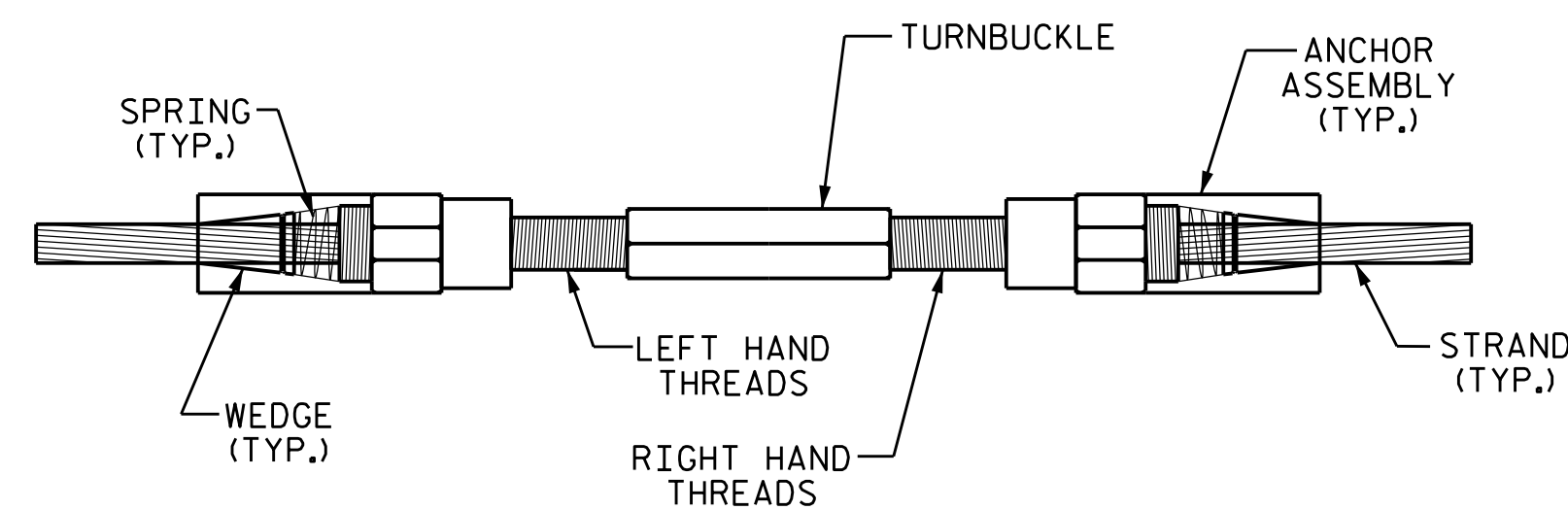

MECHANICAL STRAND SPLICE ASSEMBLY
(ASSEMBLIES MAY VARY DEPENDING ON MANUFACTURER)

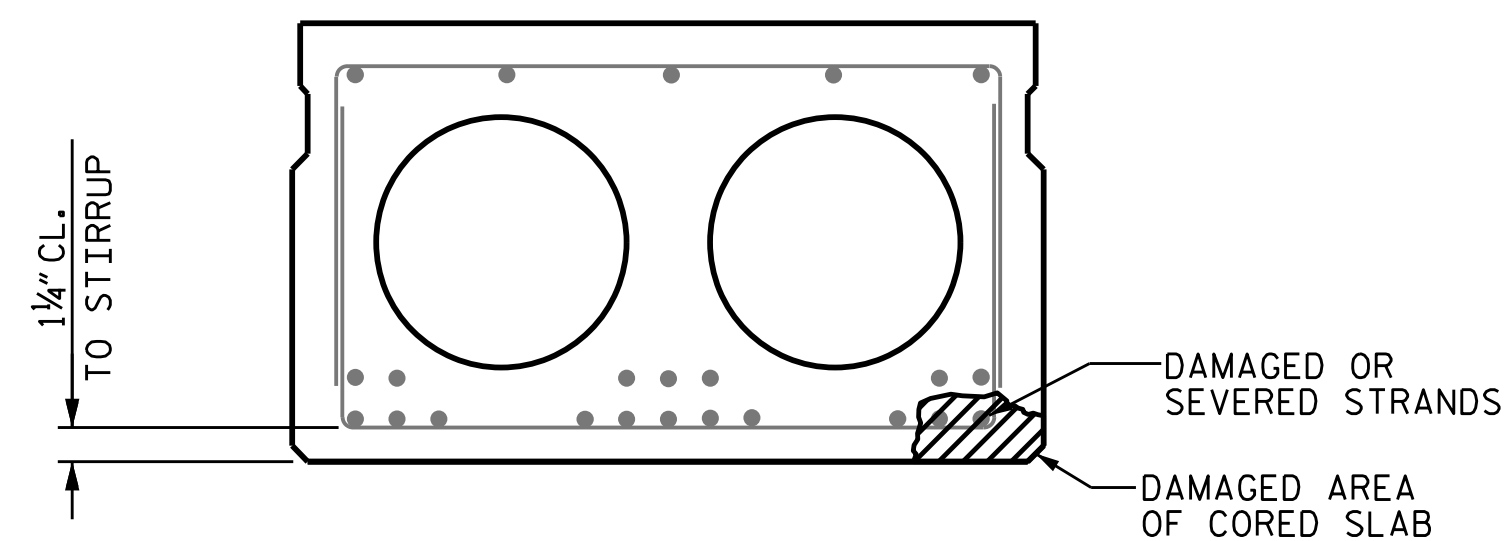

MECHANICAL STRAND SPLICE DETAIL



CORED SLAB SECTION WITH EXPOSED DAMAGED PRESTRESSED STRANDS

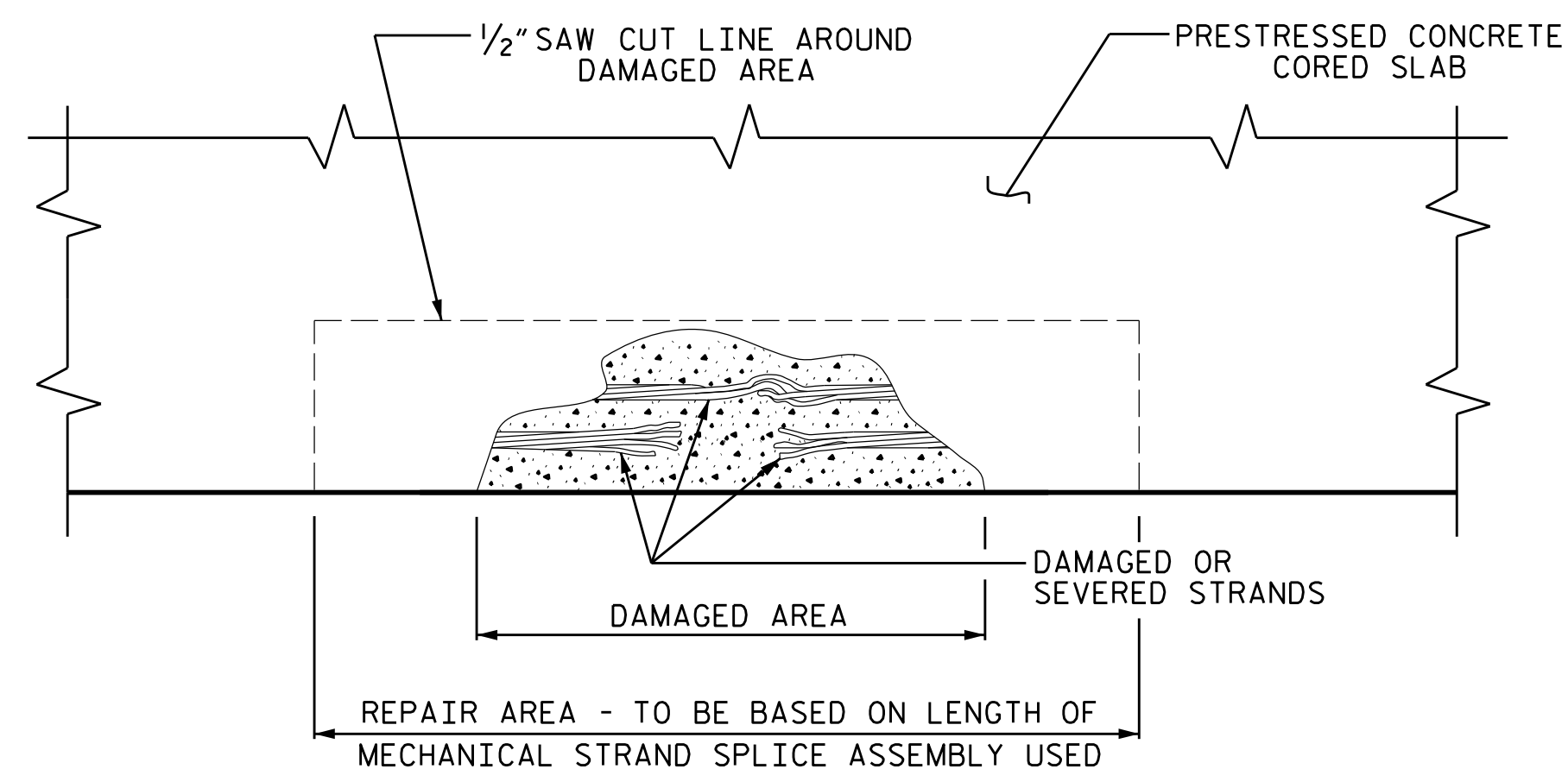

CORED SLAB ELEVATION VIEW WITH EXPOSED DAMAGED PRESTRESSED STRANDS

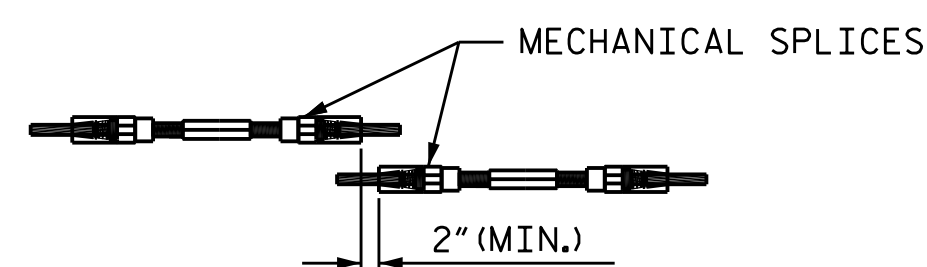

SPLICE OFFSET
STRAND REPAIR DETAILS

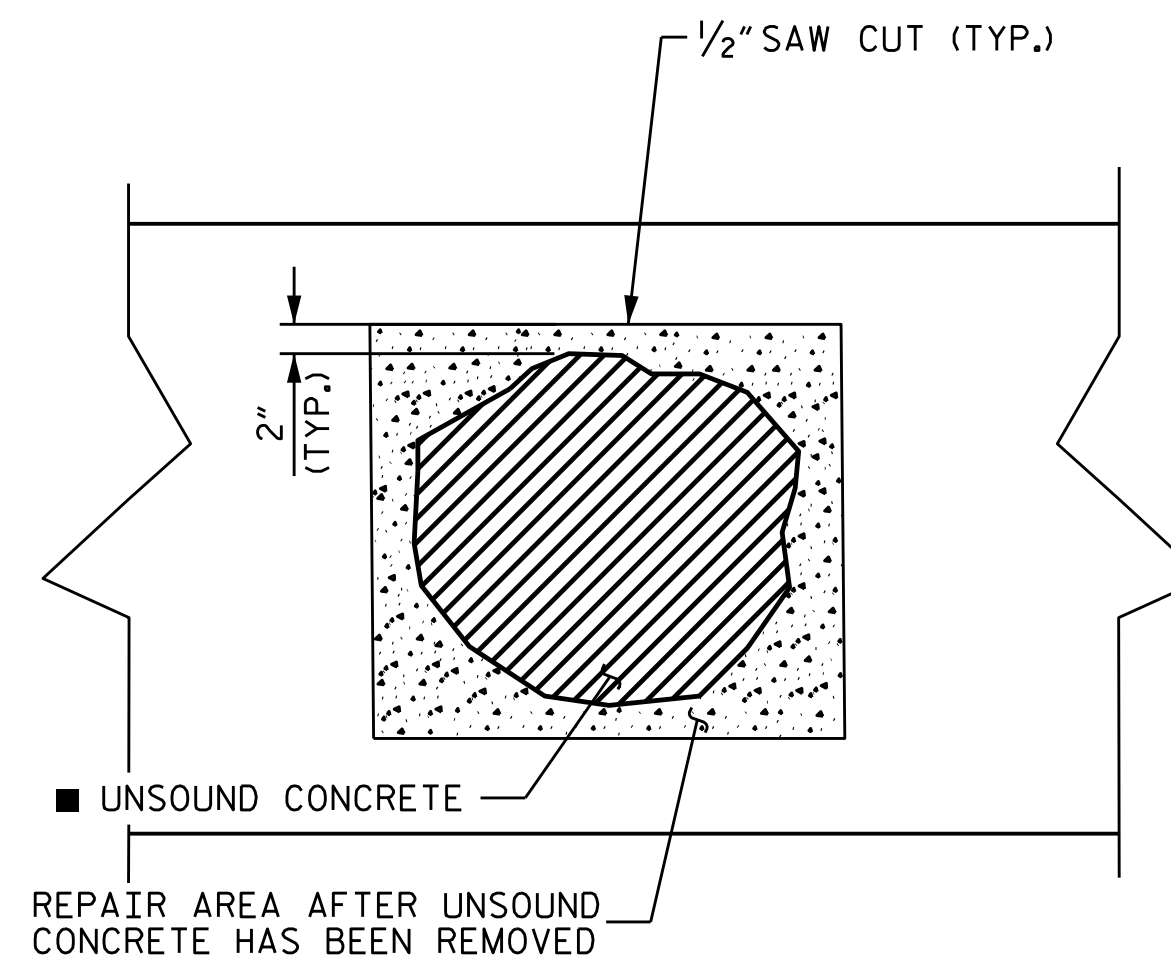

BOTTOM OF CORED SLAB

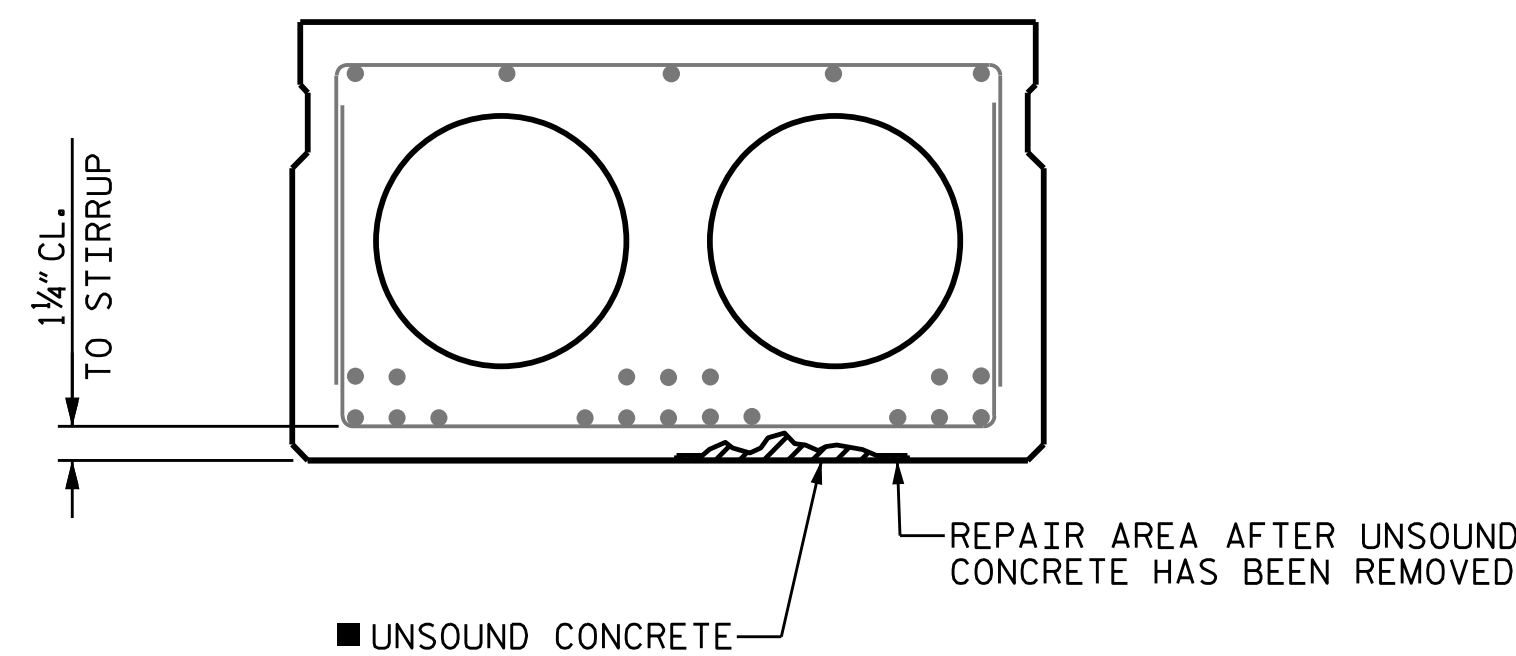

CORED SLAB SECTION

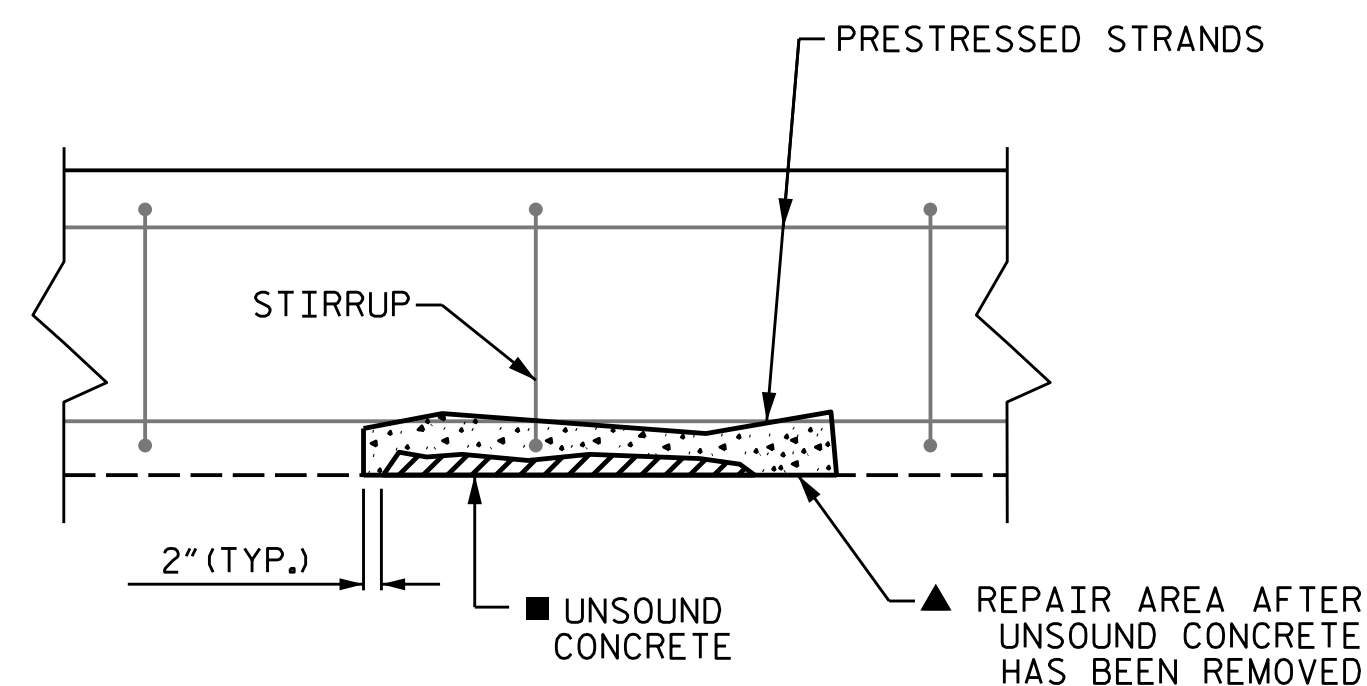

ELEVATION

NOTES:

PREPACKAGED MATERIAL IS REQUIRED.

CONSULT WITH THE ENGINEER TO DETERMINE PRELOADING REQUIREMENTS WHEN REPAIR IS WITHIN THE CENTER REGION OF THE BEAM (0.25L TO 0.75L).

FOR REPAIRS OVER RAILROAD AND SHALLOW REPAIRS THAT DO NOT ENGAGE REINFORCEMENT, ANCHOR PATCH MATERIAL USING 1/4" GALVANIZED BOLTS, EPOXY ANCHORED WITH 2" EMBEDMENT. PLACE BOLTS IN A 6" GRID. USE A LATEX OR EPOXY PATCH MATERIAL FOR IMPROVED BOND. USE EXTREME CARE TO NOT DAMAGE STRANDS.

FOR REPAIRS TO PRESTRESSED CONCRETE CORED SLABS, SEE SPECIAL PROVISIONS.

PRESTRESSED CONCRETE CORED SLAB REPAIR SEQUENCE:

- SOUND CONCRETE TO DETERMINE EXTENT OF REPAIR LOCATION.
- REMOVE SURFACE CONCRETE TO VERIFY THAT SAWCUT DEPTH WILL NOT DAMAGE EXISTING REINFORCING STEEL OR PRESTRESSING STRAND. SAW CUT AROUND REPAIR AREA TO A NOMINAL DEPTH OF 1/2".
- REMOVE CONCRETE WITHIN SAW CUT AREA TO MINIMUM 1/2" DEPTH. IF CONCRETE IS DAMAGED BEYOND THE ORIGINAL SAW CUT, A NEW SAW CUT IS REQUIRED.
- ▲ IF MORE THAN HALF THE CIRCUMFERENCE OF A REINFORCING BAR IS EXPOSED DURING THIS PROCESS, REMOVE ADDITIONAL CONCRETE TO 1" BEHIND THE BAR. THIS DOES NOT APPLY TO PRESTRESSED STRANDS.
- ALL UNSOUND CONCRETE MUST BE REMOVED, HOWEVER, PRESTRESSED STRANDS SHOULD NOT BE DISTURBED UNLESS ABSOLUTELY NECESSARY. USE EXTREME CARE TO NOT DAMAGE STRANDS.
- CLEAN AND PREPARE REINFORCING BARS AND PRESTRESSING STRANDS IN ACCORDANCE WITH THE SPECIAL PROVISIONS FOR REPAIRS TO PRESTRESSED CONCRETE CORED SLABS. FOR BARS WITH MORE THAN 10% SECTION LOSS, SPLICE AND SECURELY TIE SUPPLEMENTAL REINFORCING BARS AS NEEDED. NOTE AND PROVIDE DETAILED DOCUMENTATION, INCLUDING LOCATION AND SEVERITY, OF ALL DAMAGE TO PRESTRESSED STRANDS THAT EXCEEDS 10% SECTION LOSS. IF THREE OR MORE STRANDS ARE DAMAGED, NOTIFY THE ENGINEER PRIOR TO PLACEMENT OF REPAIR MATERIAL.
- REMOVE ALL LOOSE OR WEAKENED MATERIAL THEN CLEAN THE REPAIR AREA OF DIRT, GREASE, OIL, AND FOREIGN MATTER.
- PREPARE SURFACE AND PLACE APPROVED REPAIR MATERIAL ACCORDING TO MANUFACTURER'S RECOMMENDATIONS. MAXIMUM AGGREGATE SIZE FOR REPAIR MATERIAL SHALL NOT EXCEED 2/3 THE MINIMUM REPAIR DEPTH.

PRESTRESSED STRAND REPAIR SEQUENCE:

- REMOVE LIVE LOAD FROM REPAIR AREA BY EITHER CLOSING THE BRIDGE TO TRAFFIC OR SHIFTING TRAFFIC AWAY FROM REPAIR AREA.
- MEASURE OUT THE AREA NEEDED TO HAVE ADEQUATE ROOM TO SPLICE THE BROKEN OR DAMAGED STRAND. IF MULTIPLE STRANDS ARE BROKEN ADJACENT TO ONE ANOTHER THEN THE SPLICES SHALL BE STAGGERED. SEE "SPLICE OFFSET" DETAIL. AFTER YOU HAVE DETERMINED THE REPAIR AREA NEEDED, SAW CUT A MINIMUM OF 1/2" AT RIGHT ANGLES AROUND THE DAMAGED AREA. CHIP OUT REST OF CONCRETE TO A SUFFICIENT REPAIR DEPTH.
- SPLICE STRANDS USING THE MECHANICAL SPLICE STRAND ASSEMBLY AND TENSION TO REQUIRED FORCE PER THE MANUFACTURER'S GUIDELINES.
- PATCH REPAIR AREA USING NON-SHRINK GROUT. PROFILE OF GIRDER MAY NEED TO BE INCREASED AROUND REPAIR AREA TO PROVIDE PROPER COVER.
- AFTER GROUT HAS CURED PLACE TRAFFIC BACK ON BRIDGE OR REPAIRED AREA OF BRIDGE.

PROJECT NO. **HI-0017**
ROBESON COUNTY
BRIDGE NO. **770454**



STATE OF NORTH CAROLINA
DEPARTMENT OF TRANSPORTATION
RALEIGH

STANDARD

**TYPICAL PCCS
REPAIR DETAILS**

ASSEMBLED BY : JGB	DATE : 11/2022
CHECKED BY : SW	DATE : 11/2022
DRAWN BY :	
CHECKED BY :	

9/14/2023
S:\DPG\Division6\HI-0017\Plans\770454\404.013.HI-0017.SMU.GRD1.S4-07.770454.dgn
qabr.dwg

DOCUMENT NOT CONSIDERED
FINAL UNLESS ALL
SIGNATURES COMPLETED

REVISIONS						SHEET NO.
NO.	BY:	DATE:	NO.	BY:	DATE:	TOTAL SHEETS
1			3			7
2			4			