

5/14/23

Prepared by

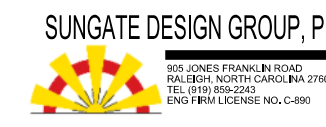

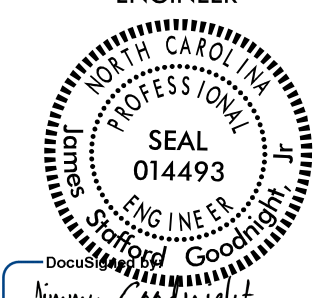
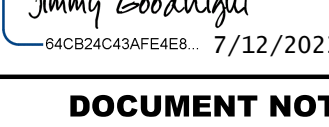

VHB Engineering NC, P.C. (C-3705)
940 Main Campus Drive, Suite 300
Raleigh, NC 27606

SUNGATE DESIGN GROUP, P.A.
10000 Sunset Blvd, Suite 100
Dallas, TX 75242
972.441.1234
www.sungatedesign.com

PROJECT REFERENCE NO. U-5312	SHEET NO. 2B-6
ROADWAY DESIGN ENGINEER	
 Documented Good Jimmy Cookmyer 646204349FE4EB 7/12/2023	
DOCUMENT NOT CONSIDERED FINAL UNLESS ALL SIGNATURES COMPLETED	

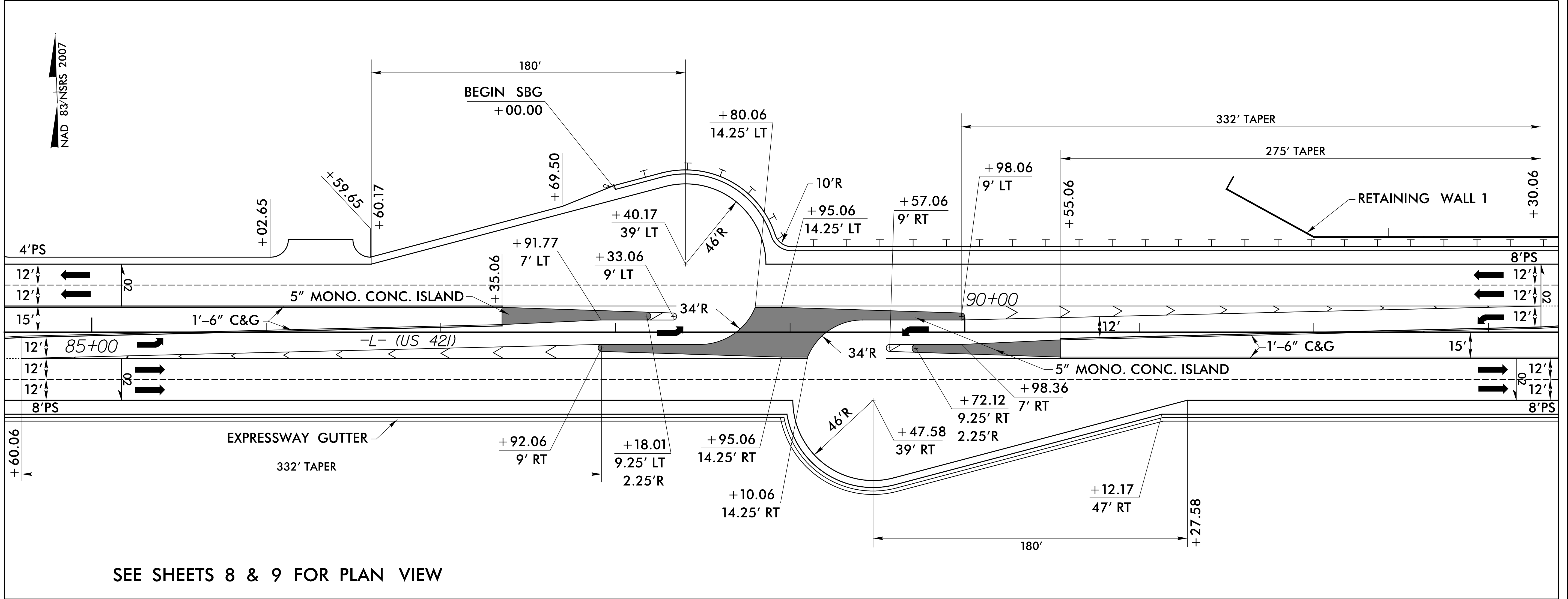
INTERSECTION DETAILS



DETAIL 4
-L- STA. 84 + 50.00 TO 93 + 40.00

- NOTES:**
- ALL DIMENSIONS ARE BASED OFF OF -L- ALIGNMENT UNLESS OTHERWISE NOTED.
 - 10' RADII FOR ALL DRIVEWAYS UNLESS OTHERWISE NOTED.
 - 2' RADII FOR ALL CONCRETE ISLANDS UNLESS OTHERWISE NOTED.

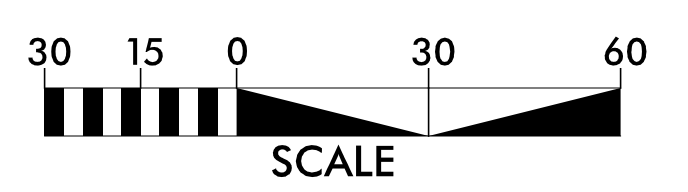

3/1/2023 3:02 PM 3/1/2023 3:02 PM 3/1/2023 3:02 PM 3/1/2023 3:02 PM 3/1/2023 3:02 PM