

REFERENCE: I-5972

PROJECT: 44989

SEE SHEET 3 FOR PLAN SHEET LAYOUT
AT TIME OF INVESTIGATION

CONTENTS

CROSS SECTIONS

LINE	STATION	SHEETS
-L-	35+50 - 46+00	4 - 11
-L-	49+50 - 82+00	11 - 32
-RPA- ¹	10+29 - 13+63	24 - 26
-RPB- ¹	10+29 - 13+82	22 - 25
-RPC- ¹	10+25 - 14+27	6 - 9
-RPD- ¹	10+21 - 13+74	7 - 10
-YI-	22+00 - 30+50	33 - 38
-YI-	32+50 - 37+00	39 - 46
-YI-	45+00 - 54+50	46 - 53
-Y2-	10+50 - 33+00	54 - 67
-RPA-	14+00 - 17+50	68 - 70
-RPB-	14+50 - 22+00	71 - 75
-RPC-	14+50 - 15+50	76
-RPC-	16+50 - 21+00	77 - 80
-RPD-	15+00 - 21+00	81 - 84
-RPD-	24+50 - 30+00	84 - 88

¹ - These cross sections are subsets of -L- cross sections.

STATE OF NORTH CAROLINA
DEPARTMENT OF TRANSPORTATION
DIVISION OF HIGHWAYS
GEOTECHNICAL ENGINEERING UNIT

ROADWAY
SUBSURFACE INVESTIGATION

COUNTY JOHNSTON

PROJECT DESCRIPTION I-95 AND US-70 BUSINESS,
(E. MARKET STREET), EXIT 95 INTERCHANGE FROM
OUTLET CENTER DRIVE TO WEST OF YELVERTON
GROVE ROAD

RECOMMENDATIONS

STATE	STATE PROJECT REFERENCE NO.	SHEET NO.	TOTAL SHEETS
N.C.	I-5972	1	88

CAUTION NOTICE

THE SUBSURFACE INFORMATION AND THE SUBSURFACE INVESTIGATION ON WHICH IT IS BASED WERE MADE FOR THE PURPOSE OF STUDY, PLANNING AND DESIGN, AND NOT FOR CONSTRUCTION OR PAY PURPOSES. THE VARIOUS FIELD BORING LOGS, ROCK CORES AND SOIL TEST DATA AVAILABLE MAY BE REVIEWED OR INSPECTED IN RALEIGH BY CONTACTING THE N. C. DEPARTMENT OF TRANSPORTATION, GEOTECHNICAL ENGINEERING UNIT AT (919) 707-6850. THE SUBSURFACE PLANS AND REPORTS, FIELD BORING LOGS, ROCK CORES AND SOIL TEST DATA ARE NOT PART OF THE CONTRACT.

GENERAL SOIL AND ROCK STRATA DESCRIPTIONS AND INDICATED BOUNDARIES ARE BASED ON A GEOTECHNICAL INTERPRETATION OF ALL AVAILABLE SUBSURFACE DATA AND MAY NOT NECESSARILY REFLECT THE ACTUAL SUBSURFACE CONDITIONS BETWEEN BORINGS OR BETWEEN SAMPLED STRATA WITHIN THE BOREHOLE. THE LABORATORY SAMPLE DATA AND THE IN SITU (ON-PLACE) TEST DATA CAN BE RELIED ON ONLY TO THE DEGREE OF RELIABILITY INHERENT IN THE STANDARD TEST METHOD. THE OBSERVED WATER LEVELS OR SOIL MOISTURE CONDITIONS INDICATED IN THE SUBSURFACE INVESTIGATIONS ARE AS RECORDED AT THE TIME OF THE INVESTIGATION. THESE WATER LEVELS OR SOIL MOISTURE CONDITIONS MAY VARY CONSIDERABLY WITH TIME ACCORDING TO CLIMATIC CONDITIONS INCLUDING TEMPERATURES, PRECIPITATION AND WIND, AS WELL AS OTHER NON-CLIMATIC FACTORS.

THE BIDDER OR CONTRACTOR IS CAUTIONED THAT DETAILS SHOWN ON THE SUBSURFACE PLANS ARE PRELIMINARY ONLY AND IN MANY CASES THE FINAL DESIGN DETAILS ARE DIFFERENT. FOR BIDDING AND CONSTRUCTION PURPOSES, REFER TO THE CONSTRUCTION PLANS AND DOCUMENTS FOR FINAL DESIGN INFORMATION ON THIS PROJECT. THE DEPARTMENT DOES NOT WARRANT OR GUARANTEE THE SUFFICIENCY OR ACCURACY OF THE INVESTIGATION MADE, NOR THE INTERPRETATIONS MADE, OR OPINION OF THE DEPARTMENT AS TO THE TYPE OF MATERIALS AND CONDITIONS TO BE ENCOUNTERED. THE BIDDER OR CONTRACTOR IS CAUTIONED TO MAKE SUCH INDEPENDENT SUBSURFACE INVESTIGATIONS AS HE DEEMS NECESSARY TO SATISFY HIMSELF AS TO CONDITIONS TO BE ENCOUNTERED ON THE PROJECT. THE CONTRACTOR SHALL HAVE NO CLAIM FOR ADDITIONAL COMPENSATION OR FOR AN EXTENSION OF TIME FOR ANY REASON RESULTING FROM THE ACTUAL CONDITIONS ENCOUNTERED AT THE SITE DIFFERING FROM THOSE INDICATED IN THE SUBSURFACE INFORMATION.

NOTES:

- THE INFORMATION CONTAINED HEREIN IS NOT IMPLIED OR GUARANTEED BY THE N. C. DEPARTMENT OF TRANSPORTATION AS ACCURATE NOR IS IT CONSIDERED PART OF THE PLANS, SPECIFICATIONS OR CONTRACT FOR THE PROJECT.
- BY HAVING REQUESTED THIS INFORMATION, THE CONTRACTOR SPECIFICALLY WAIVES ANY CLAIMS FOR INCREASED COMPENSATION OR EXTENSION OF TIME BASED ON DIFFERENCES BETWEEN THE CONDITIONS INDICATED HEREIN AND THE ACTUAL CONDITIONS AT THE PROJECT SITE.

PERSONNEL

P. CARY

J. MIZE

S&ME PERSONNEL

INVESTIGATED BY RK&K, LLP

DRAWN BY M. METRY

CHECKED BY M. SWEITZER

SUBMITTED BY RK&K, LLP

DATE OCTOBER 2021



P: (919) 878-9560
8601 Six Forks Road, Forum 1, Suite 700
Raleigh, North Carolina 27615-3960
NC License No. F-0112

Engineers | Construction Managers | Planners | Scientists
www.rkk.com

Responsive People | Creative Solutions



10/19/2021

DocuSigned by:

Margaret M. Sweitzer

4AC688A0680C4E2

SIGNATURE

DATE

**DOCUMENT NOT CONSIDERED FINAL
UNLESS ALL SIGNATURES COMPLETED**

NORTH CAROLINA DEPARTMENT OF TRANSPORTATION
DIVISION OF HIGHWAYS
GEOTECHNICAL ENGINEERING UNIT
SUBSURFACE INVESTIGATION

SOIL AND ROCK LEGEND, TERMS, SYMBOLS, AND ABBREVIATIONS

Table with multiple columns: SOIL DESCRIPTION, GRADATION, ROCK DESCRIPTION, TERMS AND DEFINITIONS, SOIL LEGEND AND AASHTO CLASSIFICATION, MINERALOGICAL COMPOSITION, COMPRESSIBILITY, PERCENTAGE OF MATERIAL, GROUND WATER, MISCELLANEOUS SYMBOLS, RECOMMENDATION SYMBOLS, ABBREVIATIONS, EQUIPMENT USED ON SUBJECT PROJECT, FRACTURE SPACING, BEDDING, INDURATION, PLASTICITY, COLOR.

09/08/99

R:\Geotech\Investigation\Design\CADD_GEO\TECH\Plan\Prof\Title sheet and Legend\5972_GEO_recs_tsh_003.dgn
9/28/2021
F:\keys

TIP PROJECT: I-5972

CONTRACT: C203991

STATE OF NORTH CAROLINA
DIVISION OF HIGHWAYS

JOHNSTON COUNTY

STATE	STATE PROJECT REFERENCE NO.	SHEET NO.	TOTAL SHEETS
N.C.	I-5972	3	88
STATE PROJ. NO.	F.A. PROJ. NO.	DESCRIPTION	
44989.1.1	NHP-0095(045)	PE	
44989.2.1	NHP-0095(045)	RW, UTILITIES	
44989.3.1	NHP-0095(045)	CONST.	

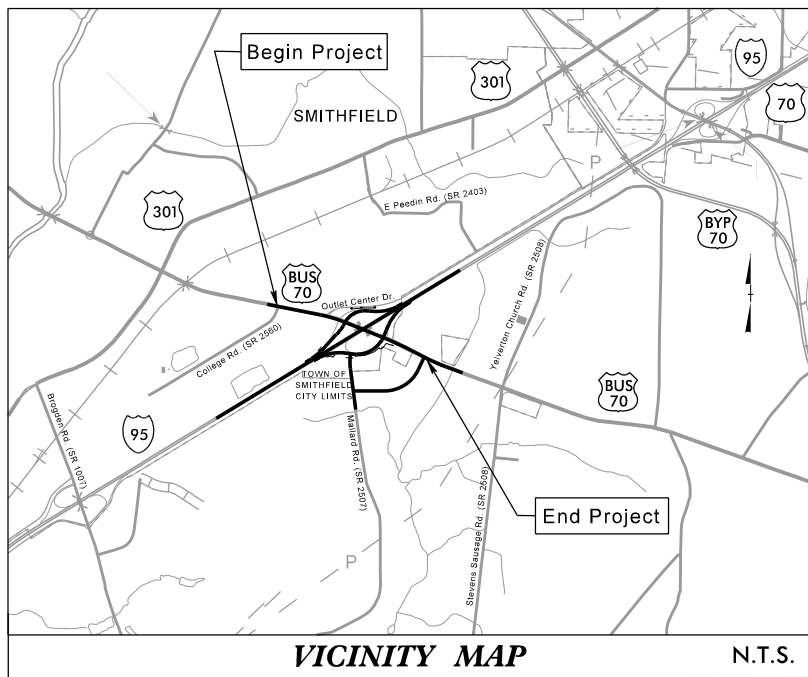

VICINITY MAP N.T.S.

LOCATION: I-95 AND US-70 BUSINESS, (E. MARKET STREET), EXIT 95 INTERCHANGE FROM OUTLET CENTER DR. TO WEST OF YELVERTON GROVE RD.
TYPE OF WORK: GRADING, DRAINAGE, PAVING, BRIDGE, SIGNING AND SIGNALS

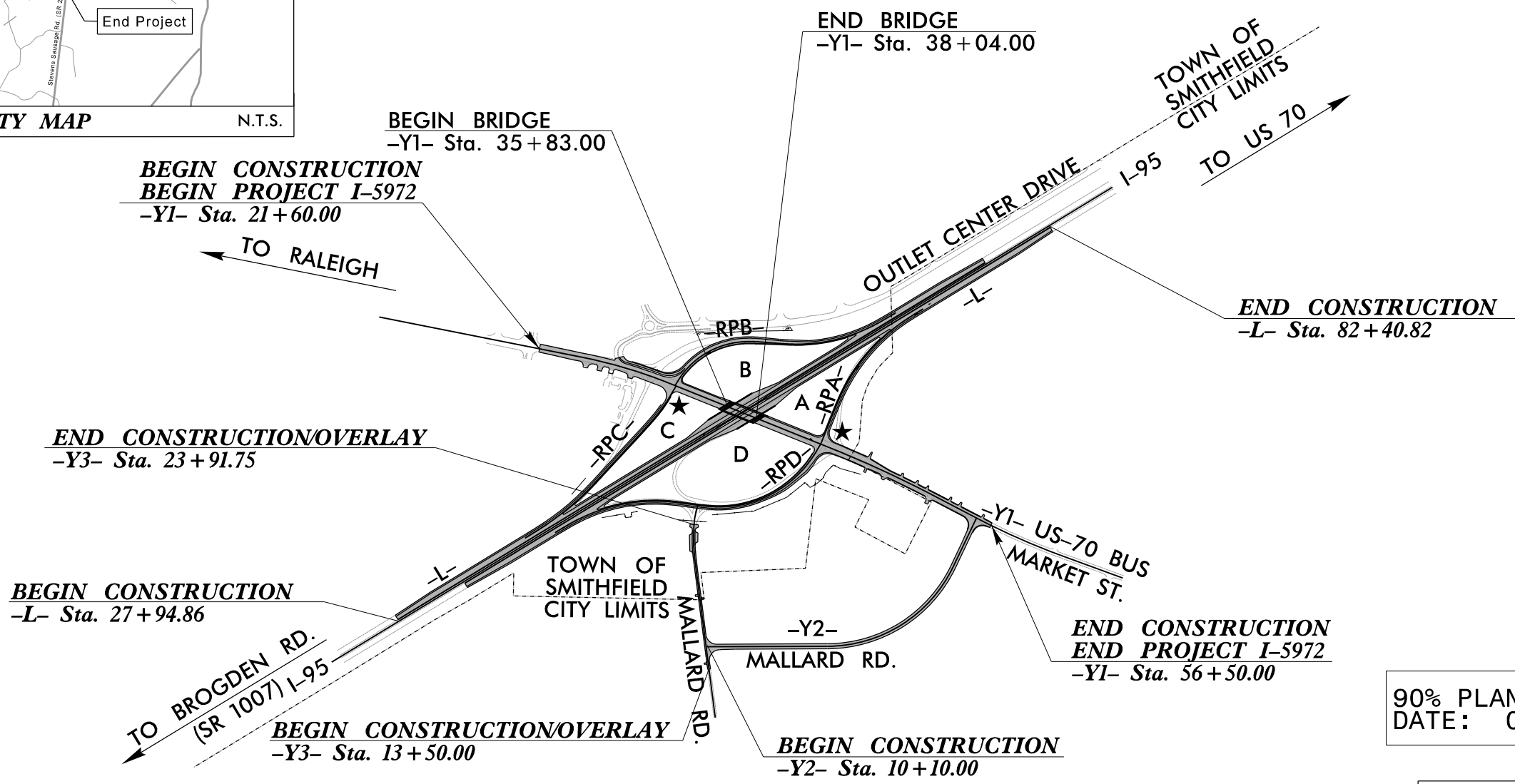

90% PLANS SUBMITTAL
DATE: 06/08/21

NOTE:
1. THIS IS A CONTROLLED-ACCESS PROJECT WITH ACCESS BEING LIMITED TO INTERCHANGES.

★ - PROPOSED SIGNALS

DOCUMENT NOT CONSIDERED FINAL
UNLESS ALL SIGNATURES COMPLETED

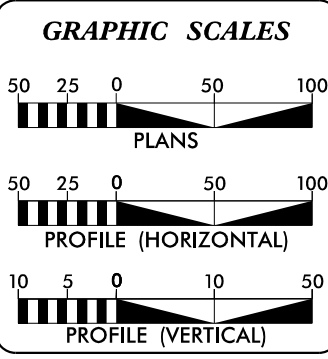

DESIGN DATA

ADT 2017 =	13,600
ADT 2040 =	17,600
K =	8 %
D =	55 %
T =	4 % *
V =	50 MPH

* (TTST 1% + DUALS 3%)

FUNC. CLASS = MINOR ARTERIAL

PROJECT LENGTH

* LENGTH OF ROADWAY PROJECT I-5972.....	0.619 mi
LENGTH OF STRUCTURE PROJECT I-5972.....	0.042 mi
TOTAL LENGTH OF PROJECT I-5972.....	0.661 mi

* BASED ON -Y1-

PREPARED IN THE OFFICE OF:
RK&K CONSULTING ENGINEERS, P.C.
FOR NORTH CAROLINA
DEPARTMENT OF TRANSPORTATION

2018 STANDARD SPECIFICATIONS	B. KEITH SKINNER, P.E. PROJECT ENGINEER
RIGHT OF WAY DATE:	MICHAEL T. MERRITT, P.E. PROJECT DESIGN ENGINEER
LETTING DATE: December 14, 2021	RUSSELL BROADWELL, P.E. DIVISION 4 PROJECT ENGINEER
NCDOT CONTACT:	RUSSELL BROADWELL, P.E. DIVISION 4 PROJECT ENGINEER

HYDRAULICS ENGINEER

SIGNATURE: _____ P.E.

ROADWAY DESIGN ENGINEER

SIGNATURE: _____ P.E.

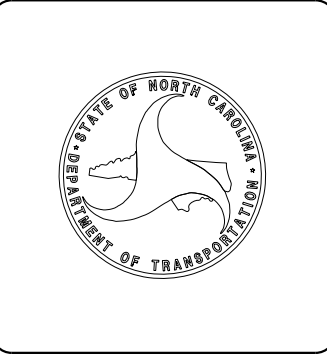

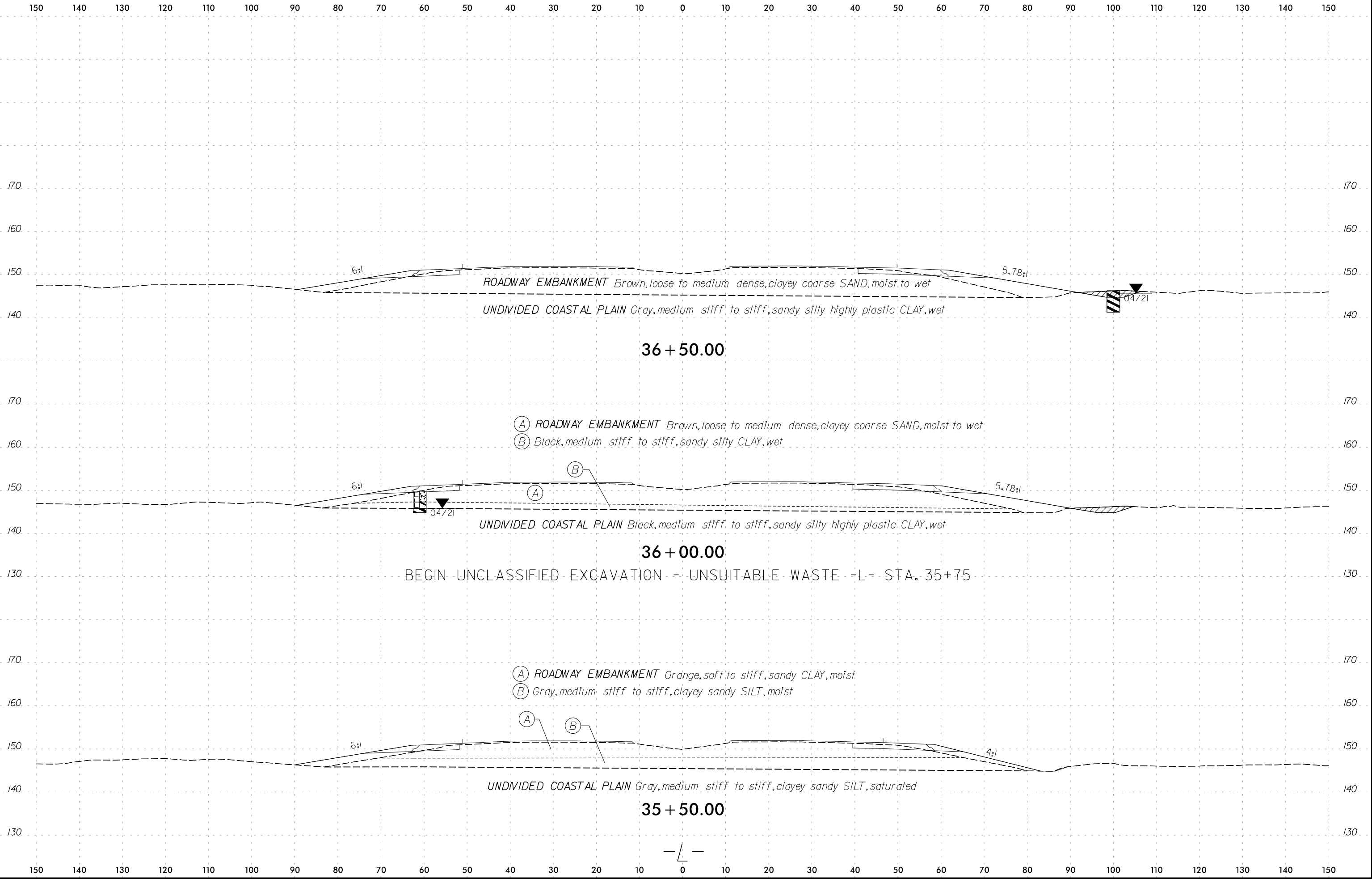

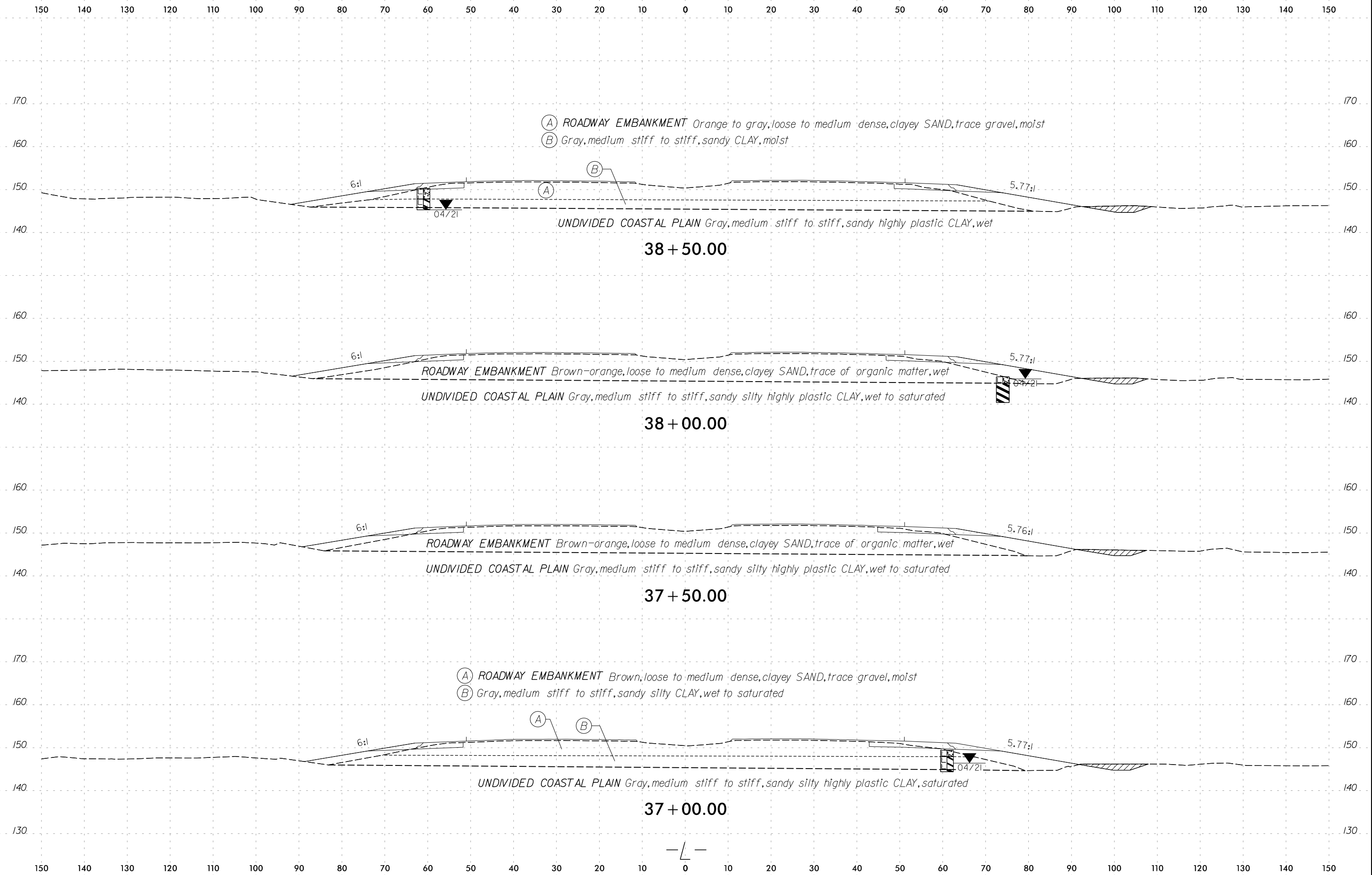

END CLASS IV SUBGRADE STABILIZATION -RPC- STA. 11+50

SAMPLE NO.	STATION	OFFSET	DEPTH INTERVAL	AASHTO CLASS.	L.L.	P.I.	% BY WEIGHT				% PASSING SIEVE			% MOISTURE	% ORGANIC
							C. SAND	F. SAND	SILT	CLAY	10	40	200		
S-22	40+00	104' RT	2.0-2.5	A-4	20	6	23	34	18	25	100	88	48	21.7	-

- (A) ROADWAY EMBANKMENT Brown, soft to stiff, coarse sandy to sandy silty highly plastic CLAY, trace gravel, moist
- (B) UNDIVIDED COASTAL PLAIN Gray, loose to medium dense, silty fine SAND, moist
- (C) Gray, medium stiff to stiff, clayey sandy SILT, moist to saturated

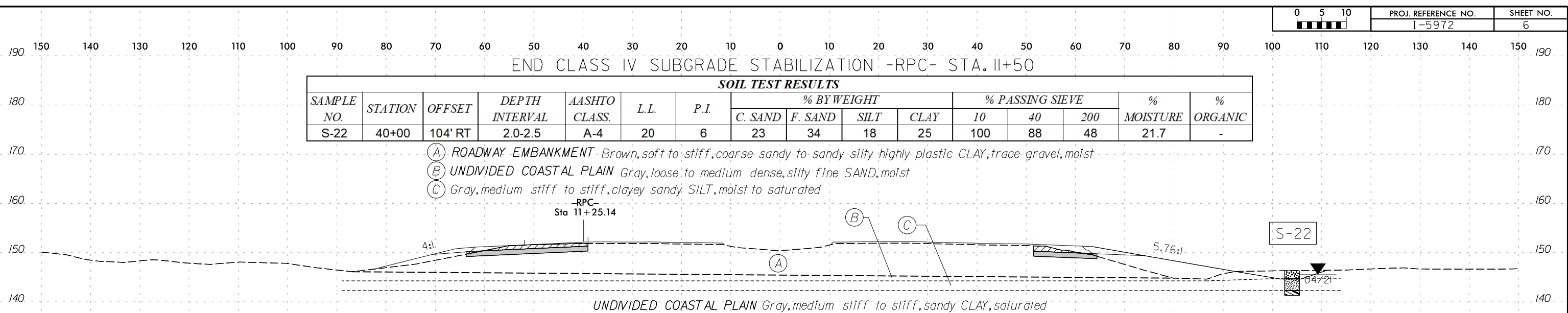

- (A) ROADWAY EMBANKMENT Brown, soft to stiff, coarse sandy to sandy silty highly plastic CLAY, trace gravel, moist
- (B) UNDIVIDED COASTAL PLAIN Gray, loose to medium dense, silty fine SAND, moist
- (C) Gray, medium stiff to stiff, clayey sandy SILT, moist to saturated

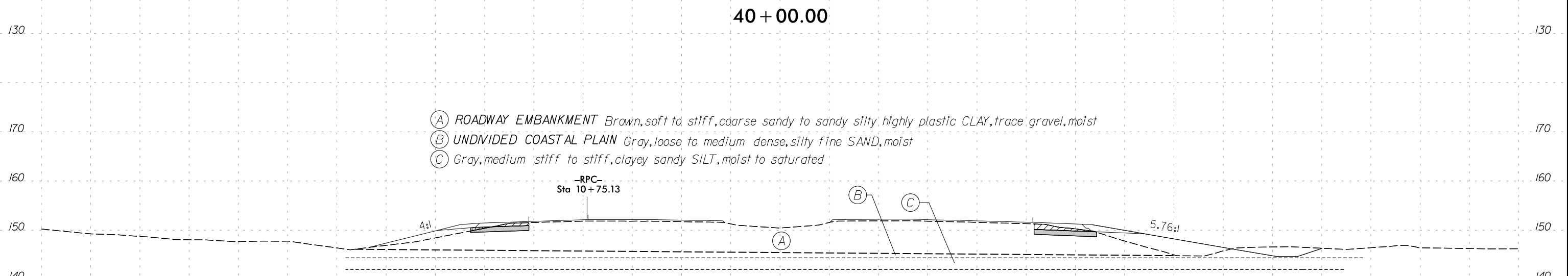

- (A) ROADWAY EMBANKMENT Brown, soft to stiff, coarse sandy to sandy silty highly plastic CLAY, trace gravel, moist to saturated

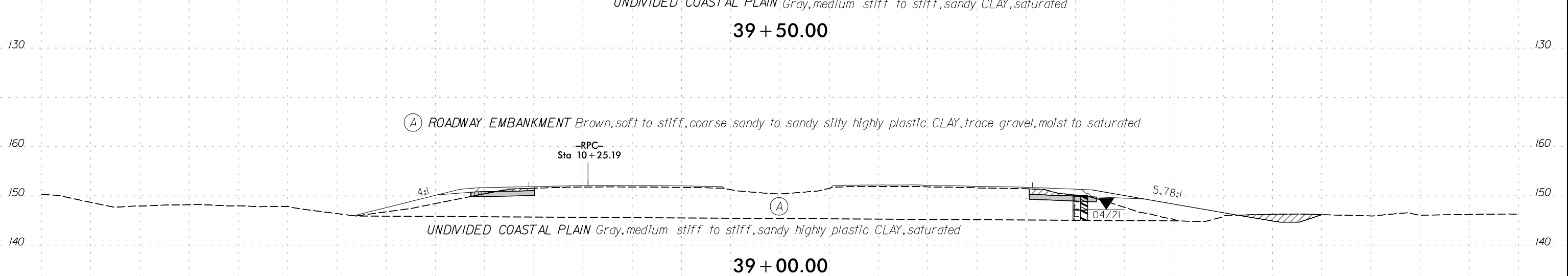

BEGIN CLASS IV SUBGRADE STABILIZATION -RPC- STA. 10+00
 BEGIN SHALLOW UNDERCUT EXCAVATION -L STA. 38+75
 BEGIN SHALLOW UNDERCUT EXCAVATION -RPC- STA. 10+00
 BEGIN UNCLASSIFIED EXCAVATION - UNSUITABLE WASTE -RPC- STA. 10+00

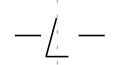

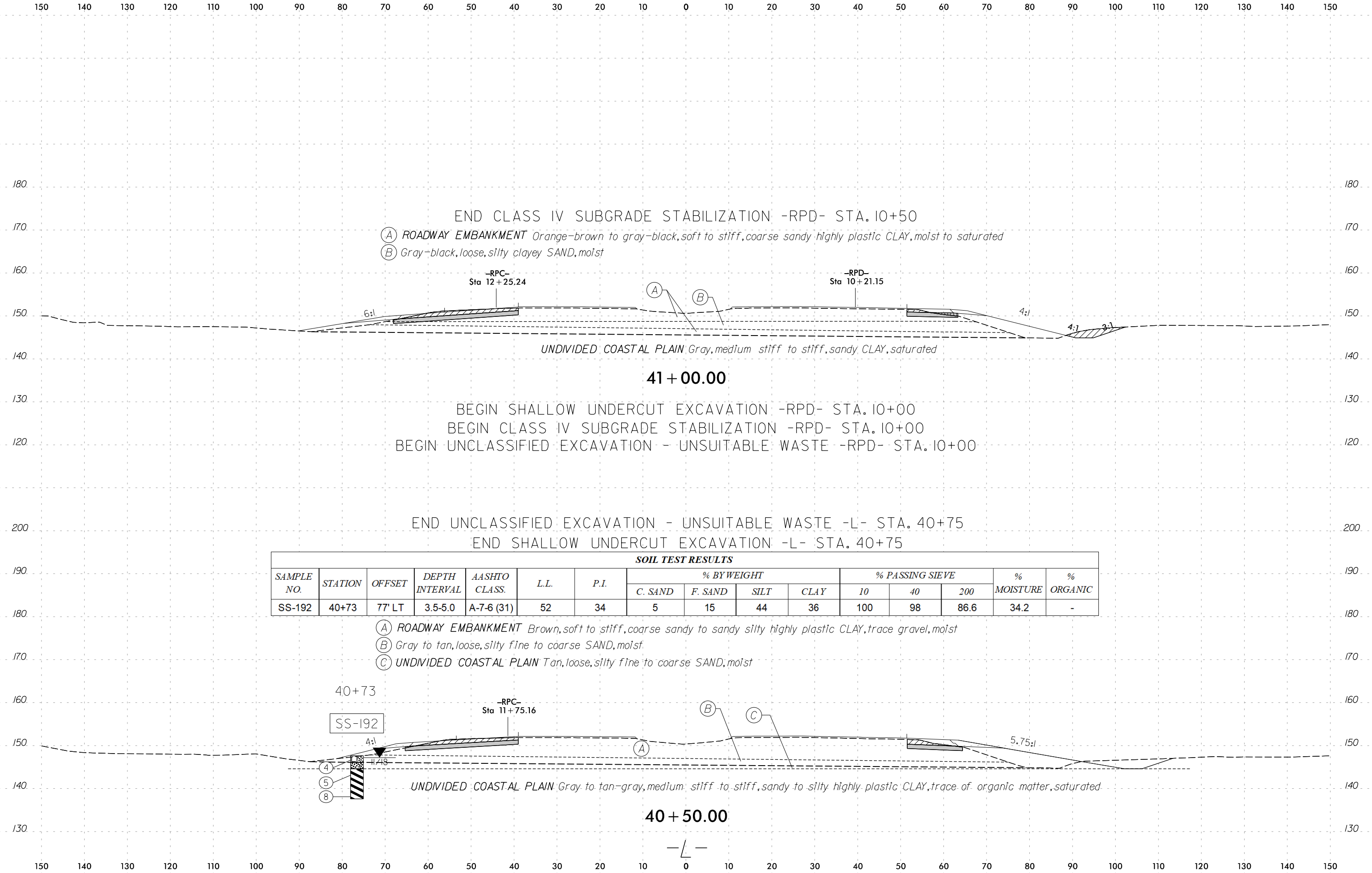

150 140 130 120 110 100 90 80 70 60 50 40 30 20 10 0 10 20 30 40 50 60 70 80 90 100 110 120 130 140 150

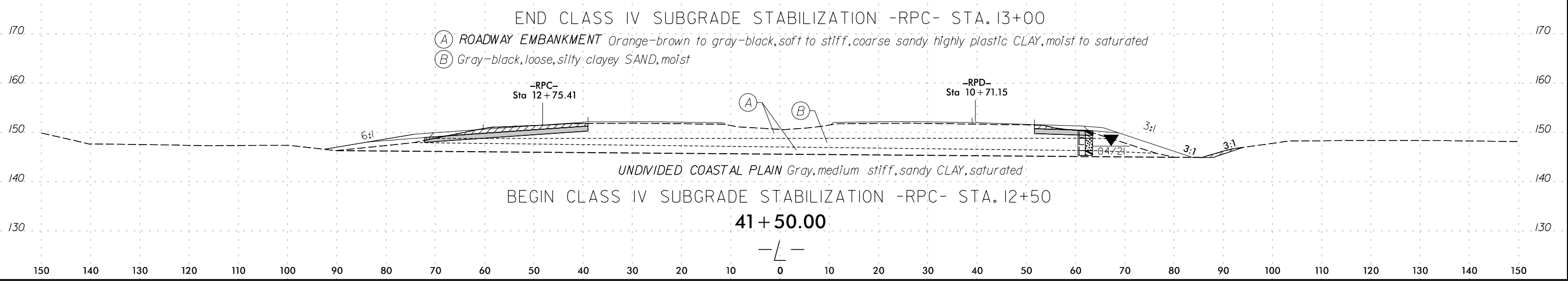
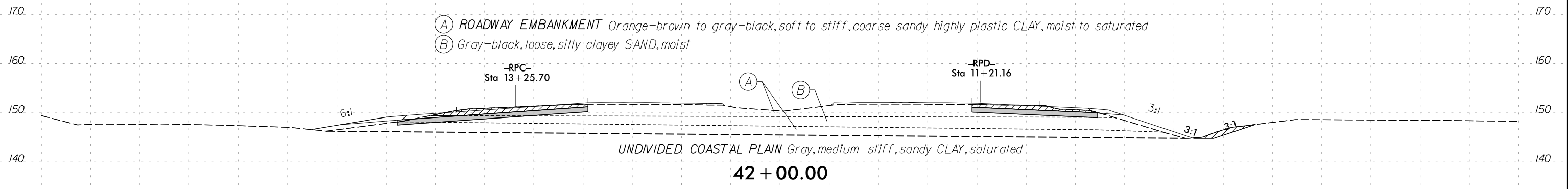
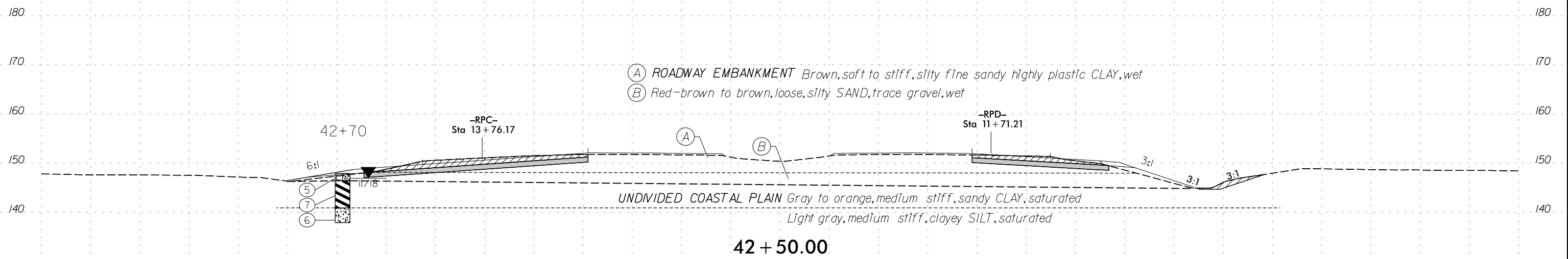

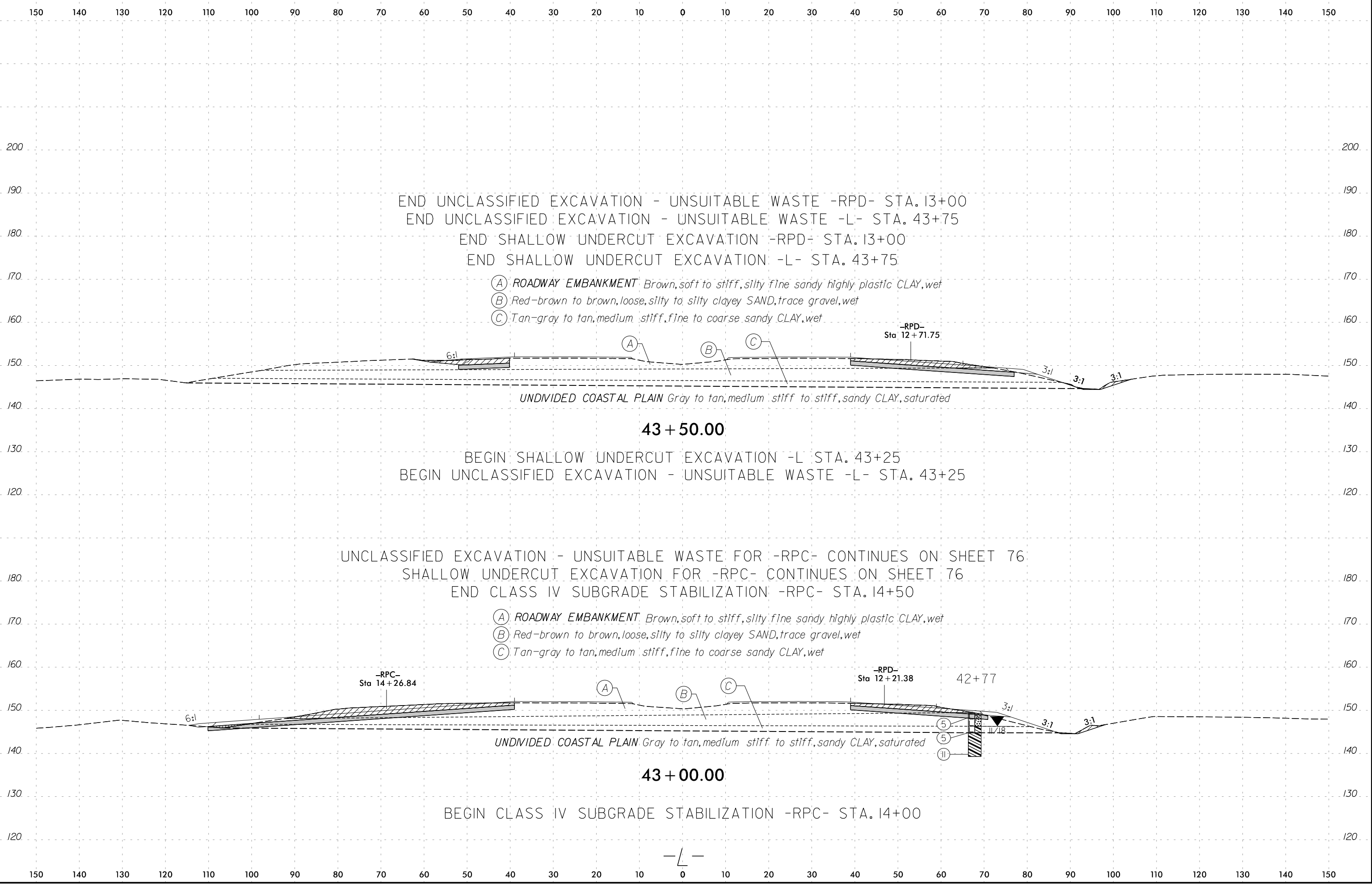

END UNCLASSIFIED EXCAVATION - UNSUITABLE WASTE -RPC- STA. 13+00
 END UNCLASSIFIED EXCAVATION - UNSUITABLE WASTE -L- STA. 43+75
 END SHALLOW UNDERCUT EXCAVATION -RPC- STA. 13+00
 END SHALLOW UNDERCUT EXCAVATION -L- STA. 43+75

- (A) ROADWAY EMBANKMENT Brown, soft to stiff, silty fine sandy highly plastic CLAY, wet
- (B) Red-brown to brown, loose, silty to silty clayey SAND, trace gravel, wet
- (C) Tan-gray to tan, medium stiff, fine to coarse sandy CLAY, wet

UNDIVIDED COASTAL PLAIN Gray to tan, medium stiff to stiff, sandy CLAY, saturated

43 + 50.00

BEGIN SHALLOW UNDERCUT EXCAVATION -L- STA. 43+25
 BEGIN UNCLASSIFIED EXCAVATION - UNSUITABLE WASTE -L- STA. 43+25

UNCLASSIFIED EXCAVATION - UNSUITABLE WASTE FOR -RPC- CONTINUES ON SHEET 76
 SHALLOW UNDERCUT EXCAVATION FOR -RPC- CONTINUES ON SHEET 76
 END CLASS IV SUBGRADE STABILIZATION -RPC- STA. 14+50

- (A) ROADWAY EMBANKMENT Brown, soft to stiff, silty fine sandy highly plastic CLAY, wet
- (B) Red-brown to brown, loose, silty to silty clayey SAND, trace gravel, wet
- (C) Tan-gray to tan, medium stiff, fine to coarse sandy CLAY, wet

UNDIVIDED COASTAL PLAIN Gray to tan, medium stiff to stiff, sandy CLAY, saturated

43 + 00.00

BEGIN CLASS IV SUBGRADE STABILIZATION -RPC- STA. 14+00

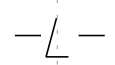

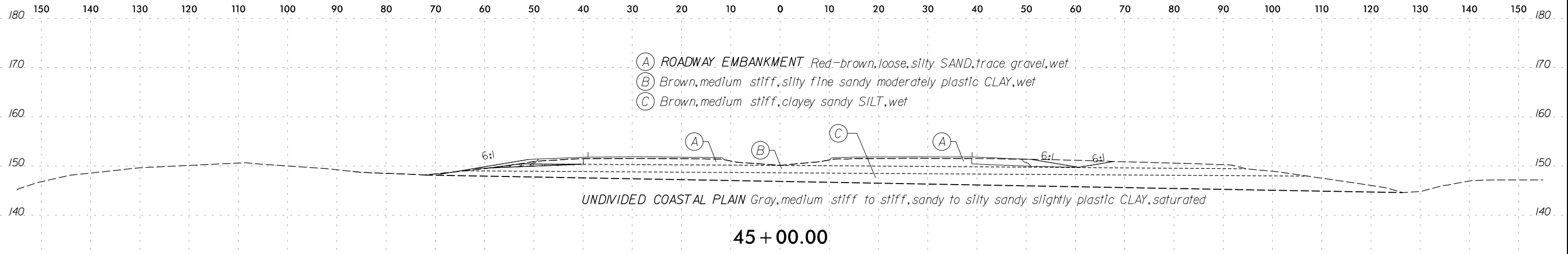

UNCLASSIFIED EXCAVATION - ACCEPTABLE FOR -RPD- CONTINUES ON SHEET 81

SOIL TEST RESULTS															
SAMPLE NO.	STATION	OFFSET	DEPTH INTERVAL	AASHTO CLASS.	L.L.	P.I.	% BY WEIGHT				% PASSING SIEVE			% MOISTURE	% ORGANIC
							C. SAND	F. SAND	SILT	CLAY	10	40	200		
SS-17	44+71	97' RT	3.5-5.0	A-6 (6)	27	12	7	26	38	29	99	95	73	19.1	-

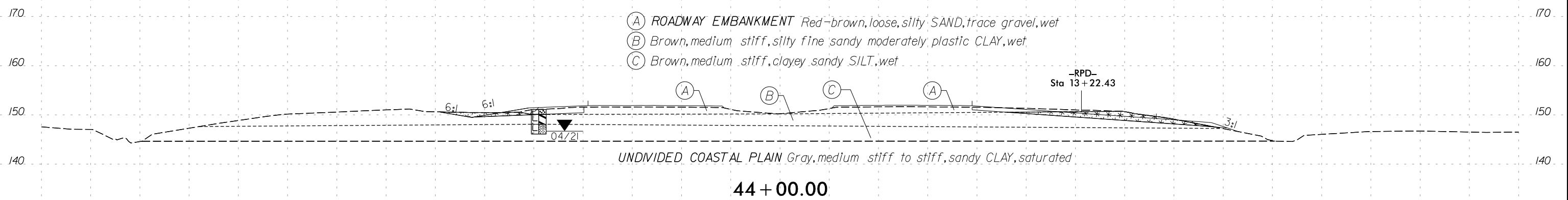
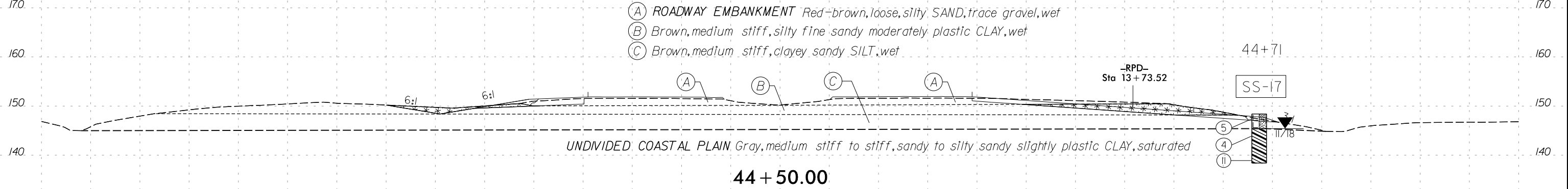

BEGIN UNCLASSIFIED EXCAVATION - ACCEPTABLE -L- STA. 43+75
 BEGIN UNCLASSIFIED EXCAVATION - ACCEPTABLE -RPD- STA. 13+00

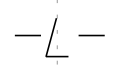



150 140 130 120 110 100 90 80 70 60 50 40 30 20 10 0 10 20 30 40 50 60 70 80 90 100 110 120 130 140 150

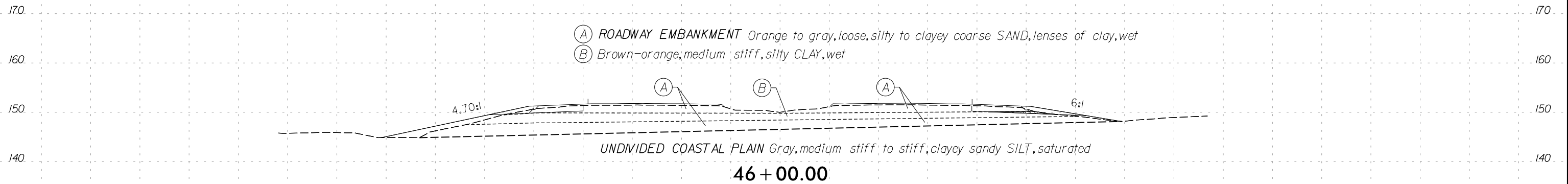
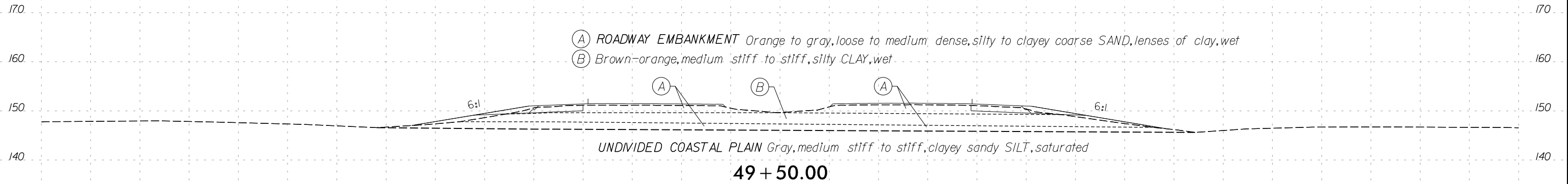

END UNCLASSIFIED EXCAVATION - ACCEPTABLE -L- STA. 45+75

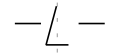
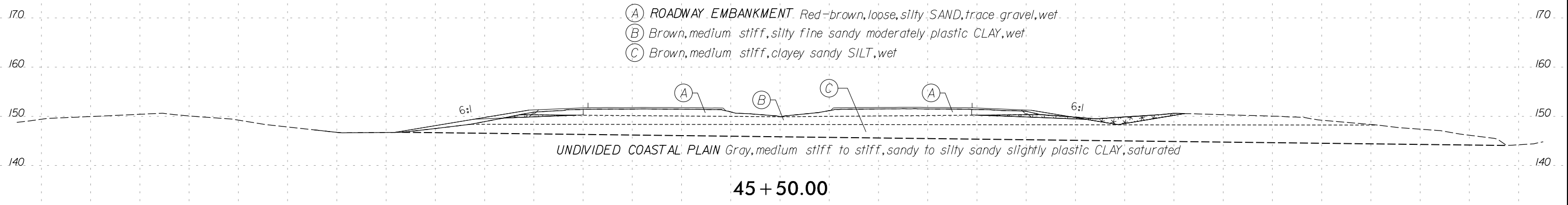

150 140 130 120 110 100 90 80 70 60 50 40 30 20 10 0 10 20 30 40 50 60 70 80 90 100 110 120 130 140 150

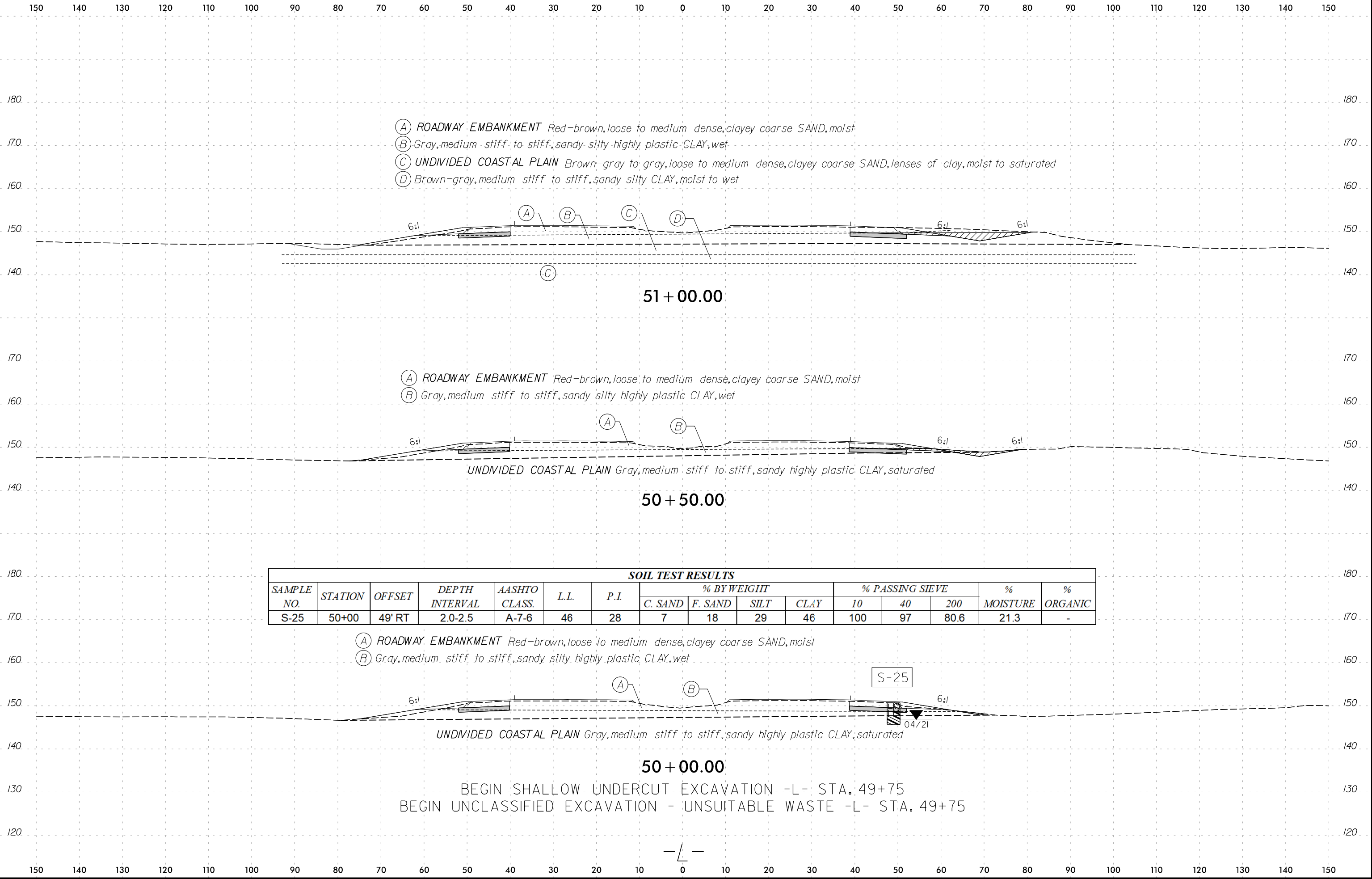

SOIL TEST RESULTS															
SAMPLE NO.	STATION	OFFSET	DEPTH INTERVAL	AASHTO CLASS.	L.L.	P.I.	% BY WEIGHT				% PASSING SIEVE			% MOISTURE	% ORGANIC
							C. SAND	F. SAND	SILT	CLAY	10	40	200		
S-25	50+00	49' RT	2.0-2.5	A-7-6	46	28	7	18	29	46	100	97	80.6	21.3	-

- (A) ROADWAY EMBANKMENT Red-brown, loose to medium dense, clayey coarse SAND, moist
- (B) Gray, medium stiff to stiff, sandy silty highly plastic CLAY, wet

150 140 130 120 110 100 90 80 70 60 50 40 30 20 10 0 10 20 30 40 50 60 70 80 90 100 110 120 130 140 150

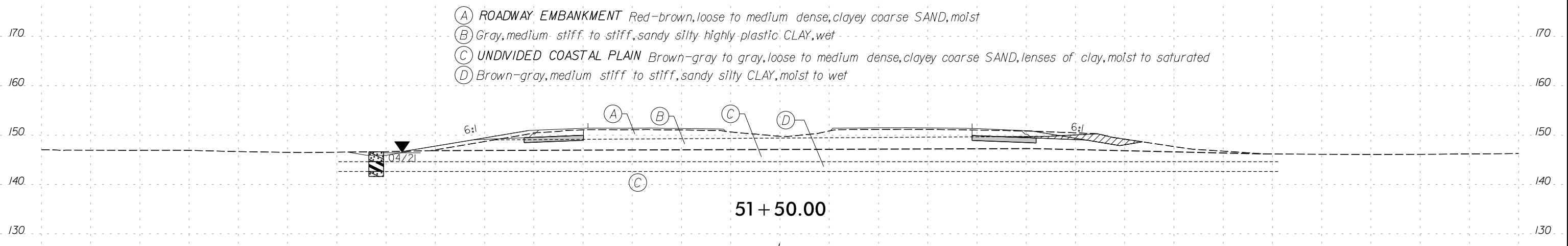
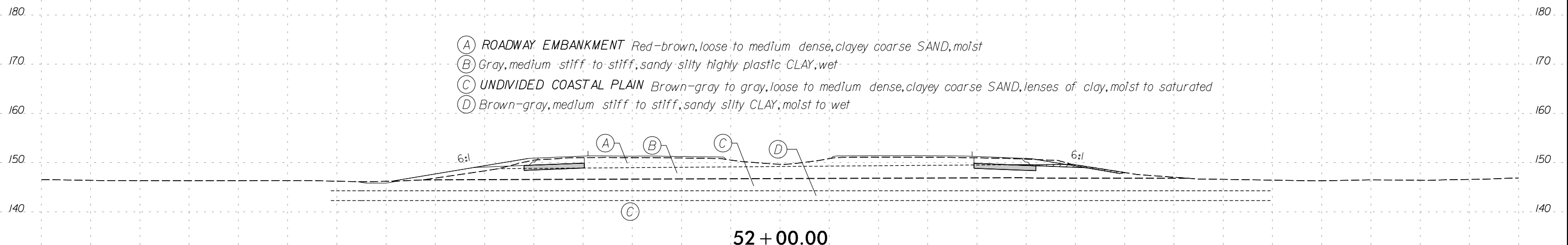
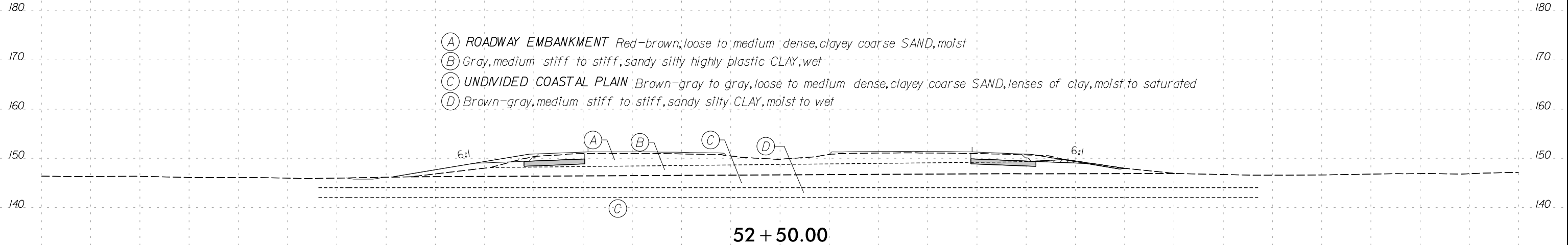

150 140 130 120 110 100 90 80 70 60 50 40 30 20 10 0 10 20 30 40 50 60 70 80 90 100 110 120 130 140 150

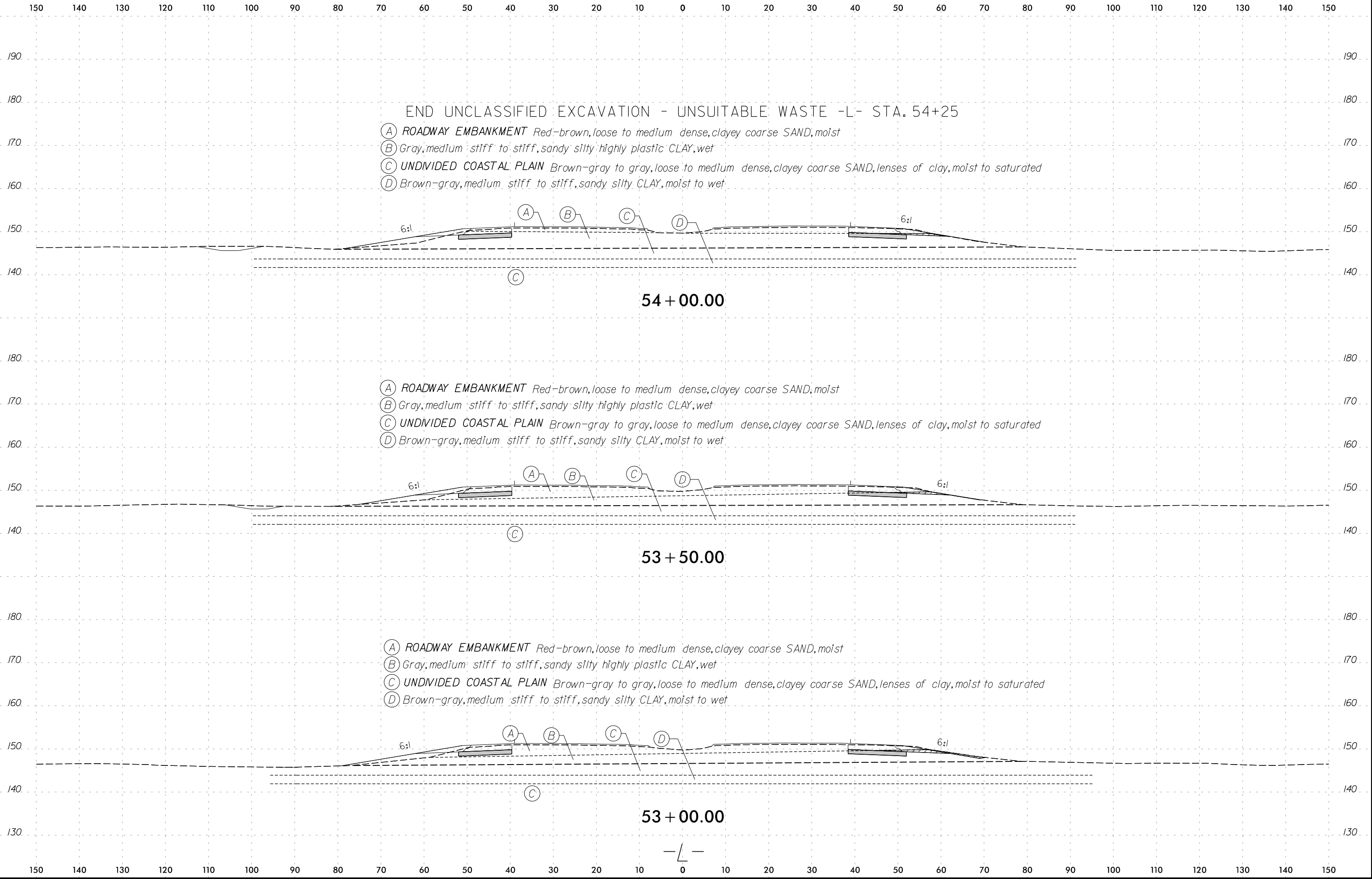

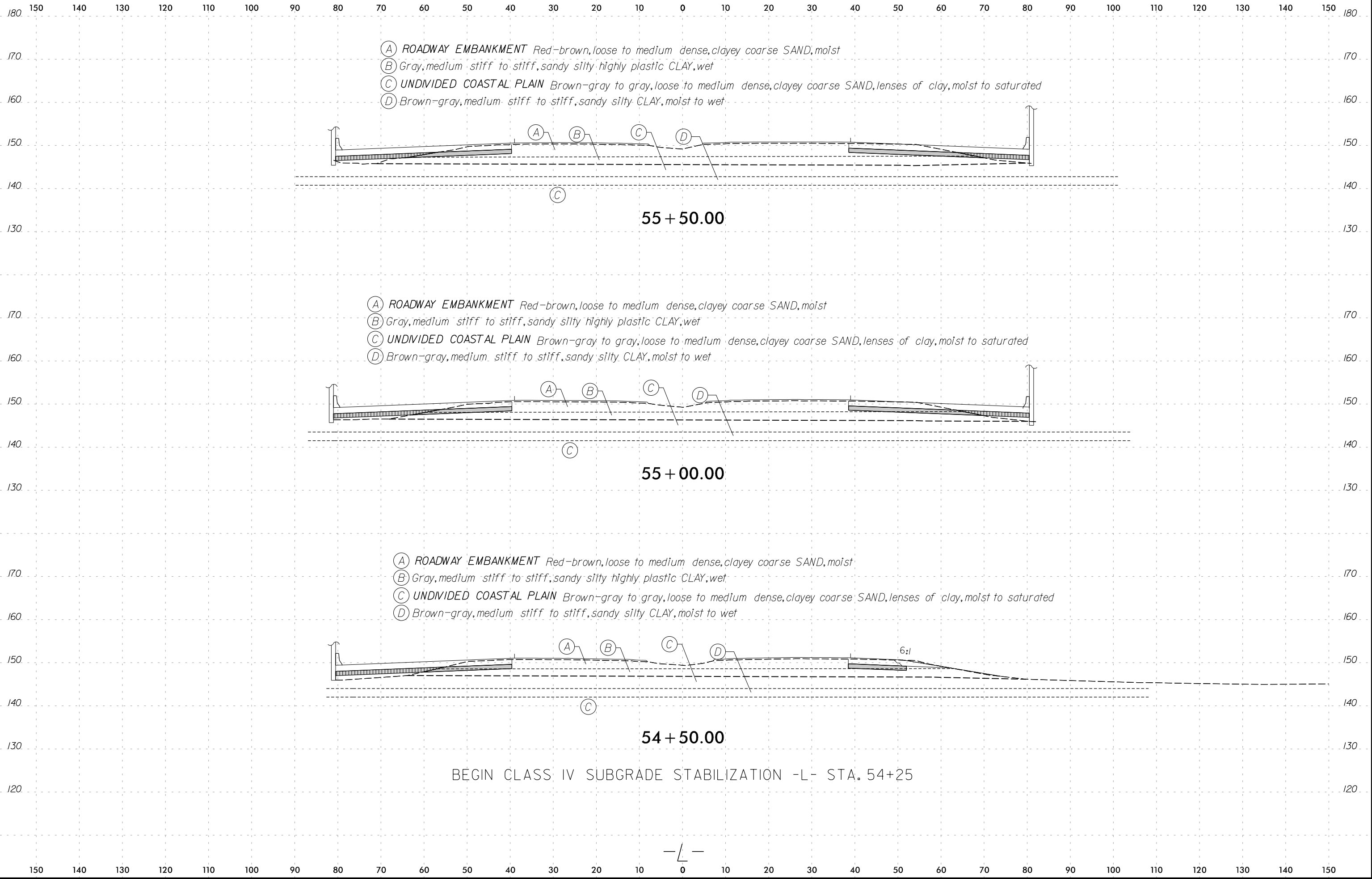

150 140 130 120 110 100 90 80 70 60 50 40 30 20 10 0 10 20 30 40 50 60 70 80 90 100 110 120 130 140 150

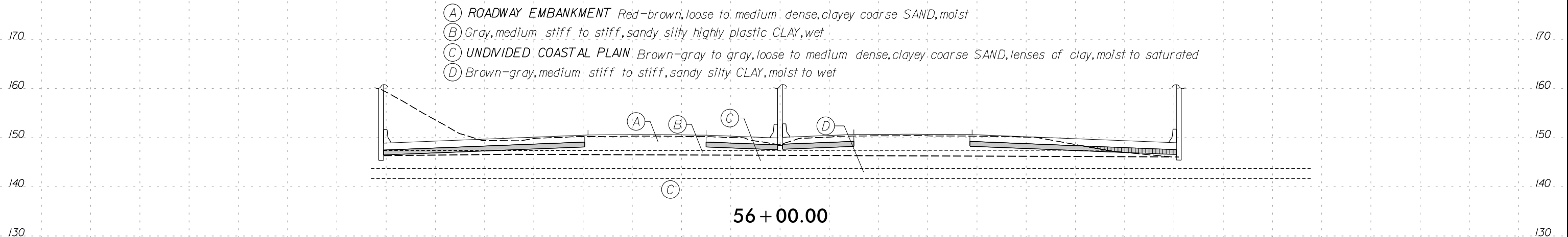
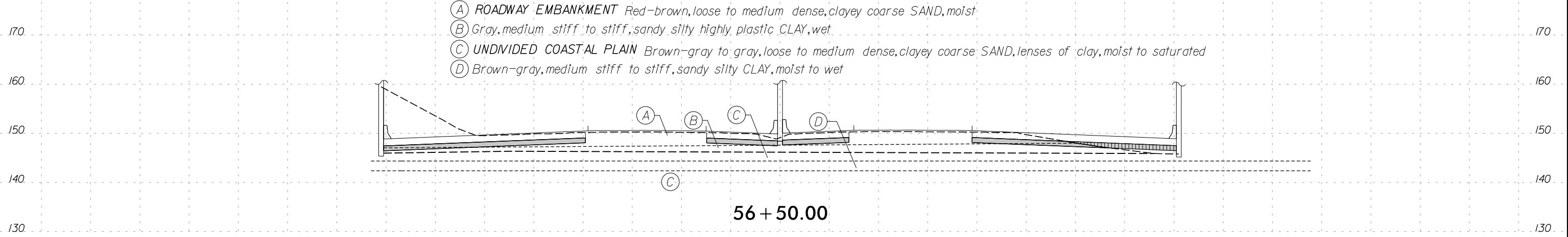
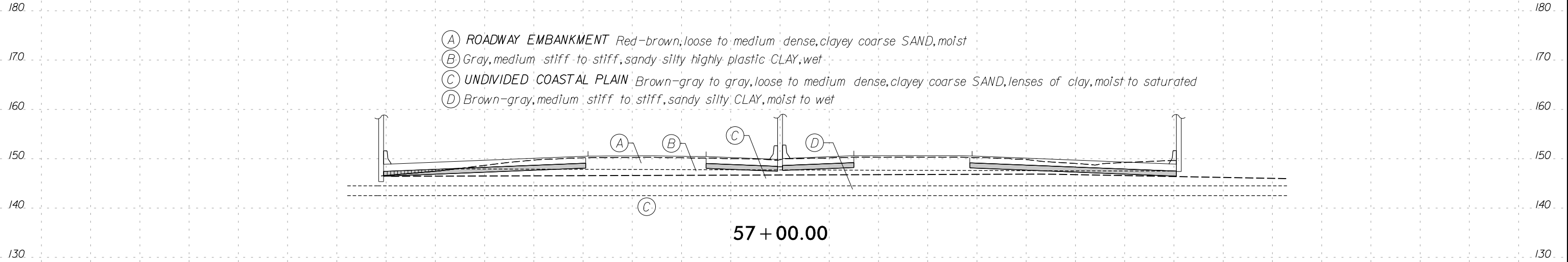

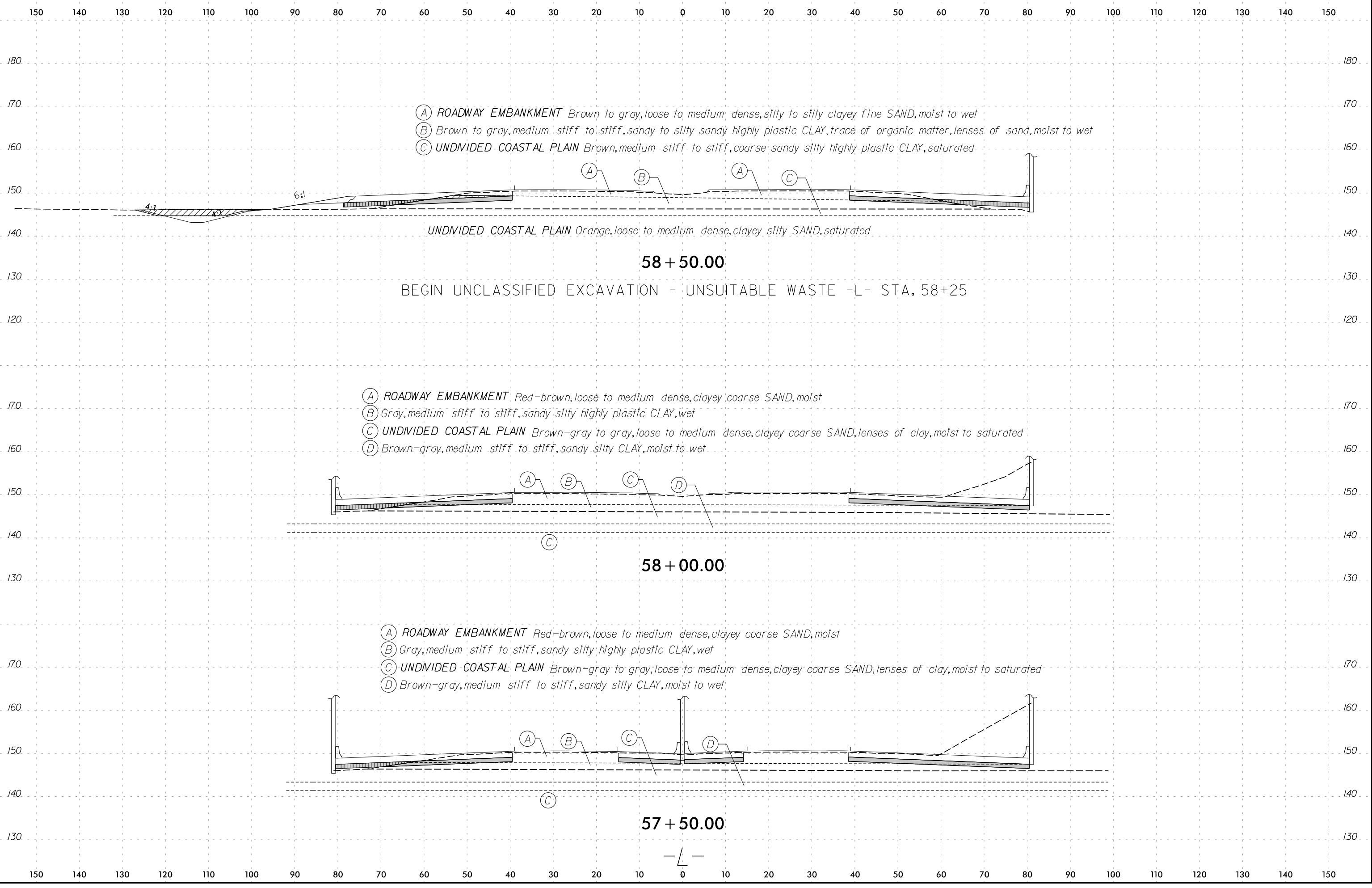

150 140 130 120 110 100 90 80 70 60 50 40 30 20 10 0 10 20 30 40 50 60 70 80 90 100 110 120 130 140 150

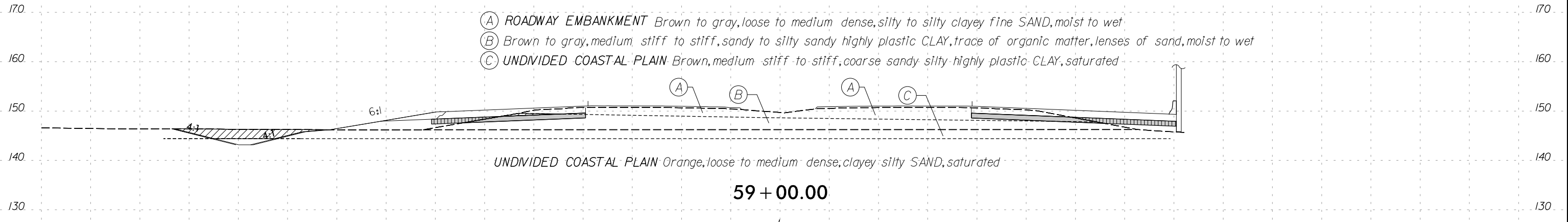
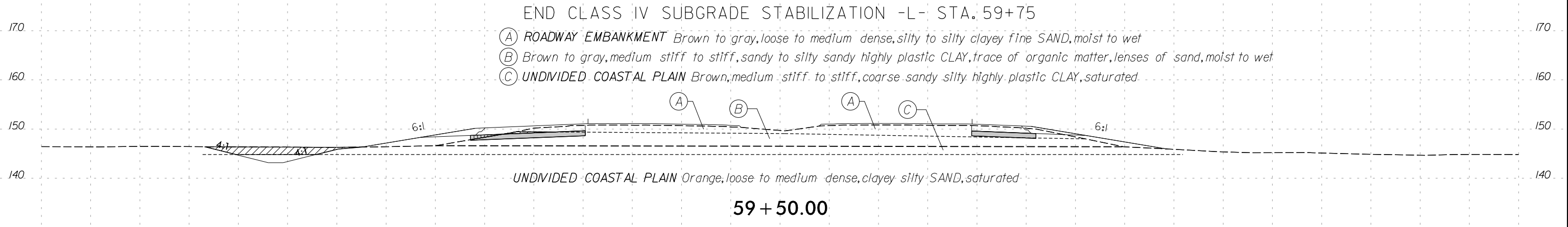
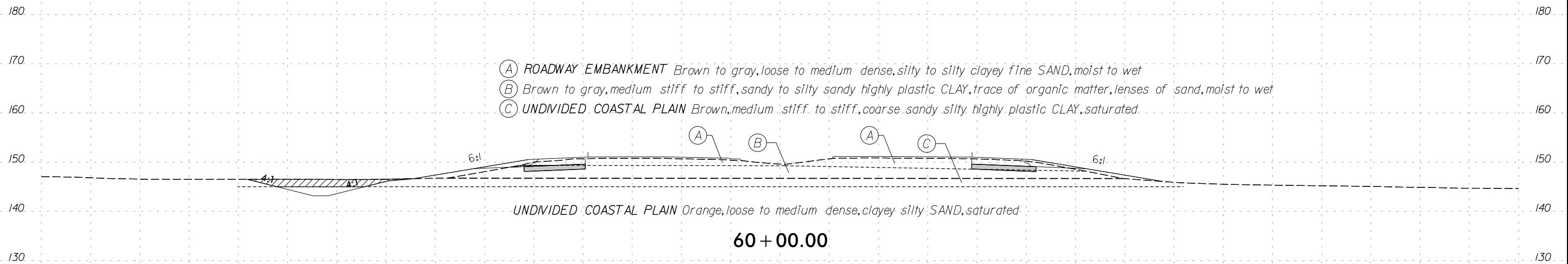

150 140 130 120 110 100 90 80 70 60 50 40 30 20 10 0 10 20 30 40 50 60 70 80 90 100 110 120 130 140 150

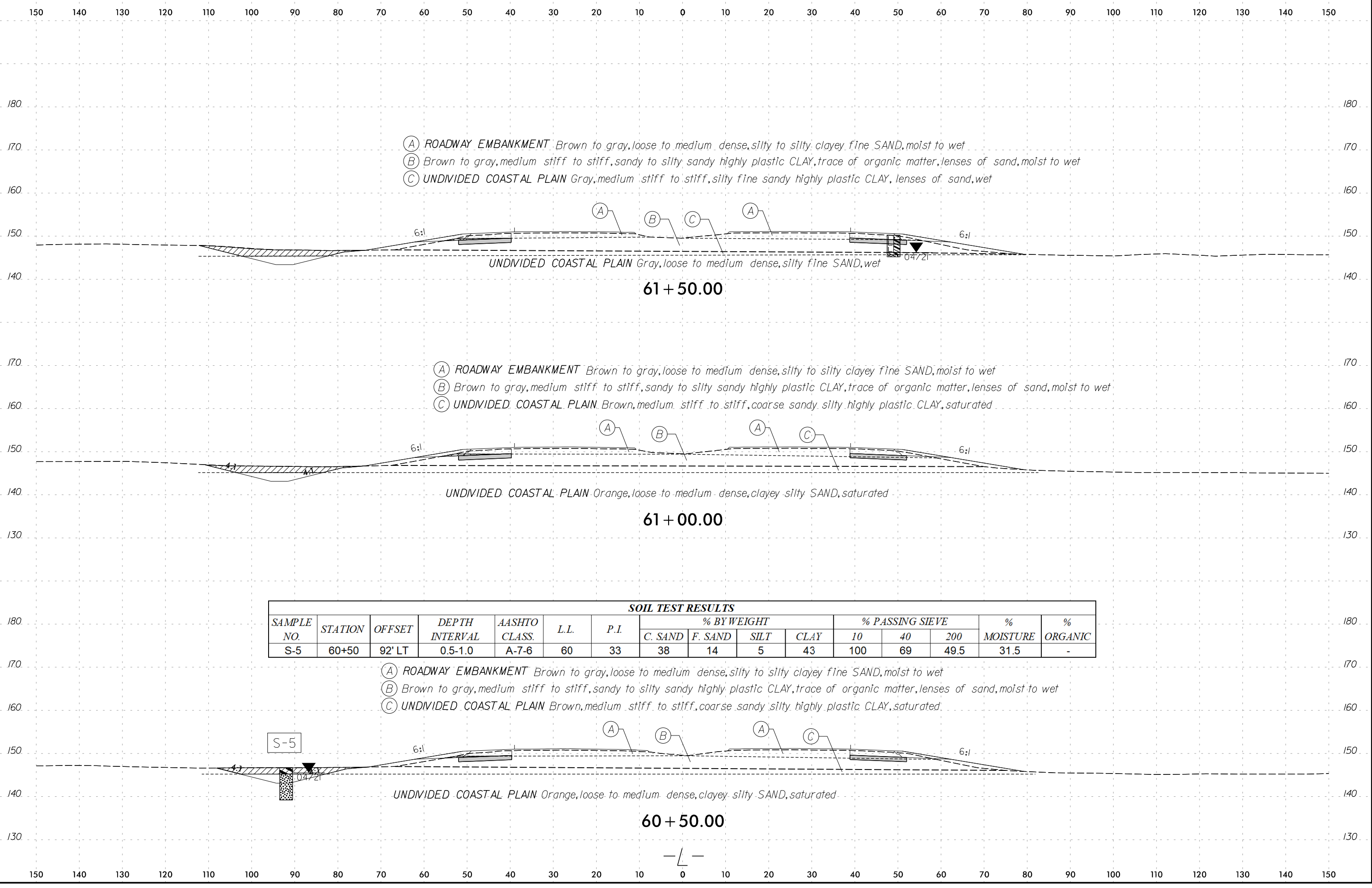

- (A) ROADWAY EMBANKMENT Brown to gray, loose to medium dense, silty to silty clayey fine SAND, moist to wet
- (B) Brown to gray, medium stiff to stiff, sandy to silty sandy highly plastic CLAY, trace of organic matter, lenses of sand, moist to wet
- (C) UNDIVIDED COASTAL PLAIN Gray, medium stiff to stiff, silty fine sandy highly plastic CLAY, lenses of sand, wet

- (A) ROADWAY EMBANKMENT Brown to gray, loose to medium dense, silty to silty clayey fine SAND, moist to wet
- (B) Brown to gray, medium stiff to stiff, sandy to silty sandy highly plastic CLAY, trace of organic matter, lenses of sand, moist to wet
- (C) UNDIVIDED COASTAL PLAIN Brown, medium stiff to stiff, coarse sandy silty highly plastic CLAY, saturated

SOIL TEST RESULTS															
SAMPLE NO.	STATION	OFFSET	DEPTH INTERVAL	AASHTO CLASS.	L.L.	P.I.	% BY WEIGHT				% PASSING SIEVE			% MOISTURE	% ORGANIC
							C. SAND	F. SAND	SILT	CLAY	10	40	200		
S-5	60+50	92' LT	0.5-1.0	A-7-6	60	33	38	14	5	43	100	69	49.5	31.5	-

- (A) ROADWAY EMBANKMENT Brown to gray, loose to medium dense, silty to silty clayey fine SAND, moist to wet
- (B) Brown to gray, medium stiff to stiff, sandy to silty sandy highly plastic CLAY, trace of organic matter, lenses of sand, moist to wet
- (C) UNDIVIDED COASTAL PLAIN Brown, medium stiff to stiff, coarse sandy silty highly plastic CLAY, saturated

S-5

150 140 130 120 110 100 90 80 70 60 50 40 30 20 10 0 10 20 30 40 50 60 70 80 90 100 110 120 130 140 150

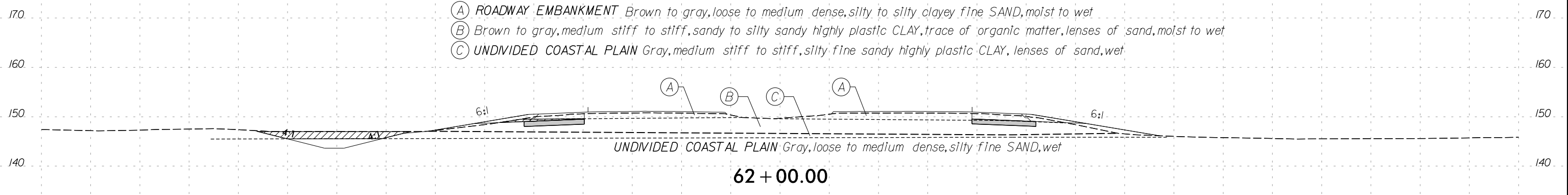
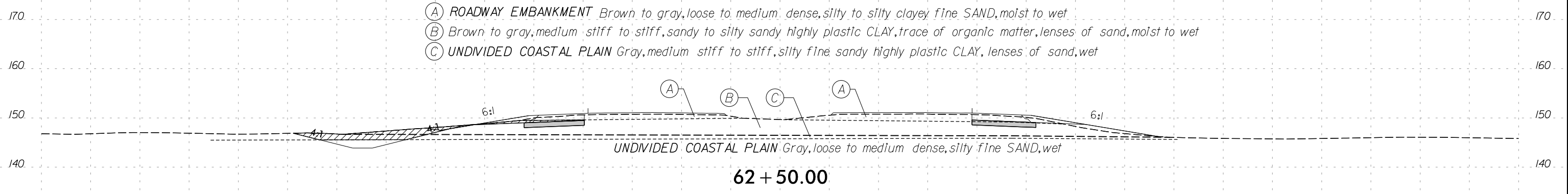
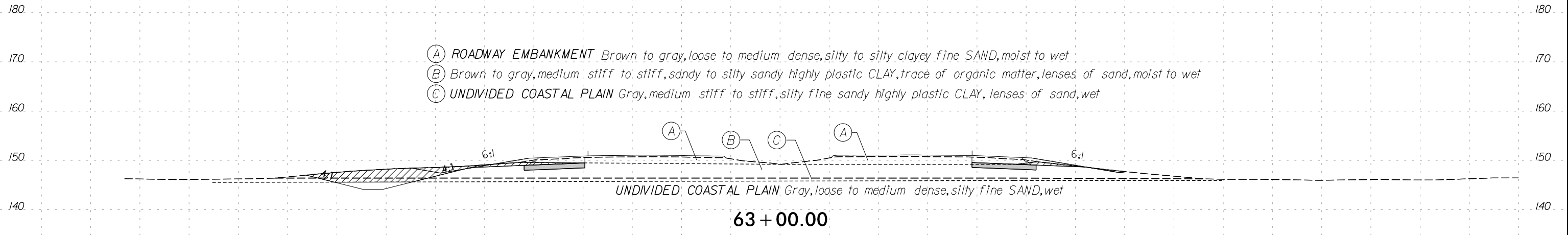

150 140 130 120 110 100 90 80 70 60 50 40 30 20 10 0 10 20 30 40 50 60 70 80 90 100 110 120 130 140 150

150 140 130 120 110 100 90 80 70 60 50 40 30 20 10 0 10 20 30 40 50 60 70 80 90 100 110 120 130 140 150

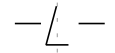
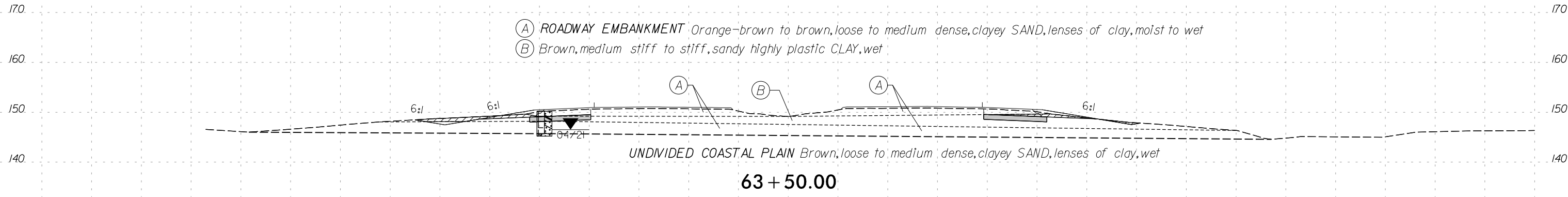
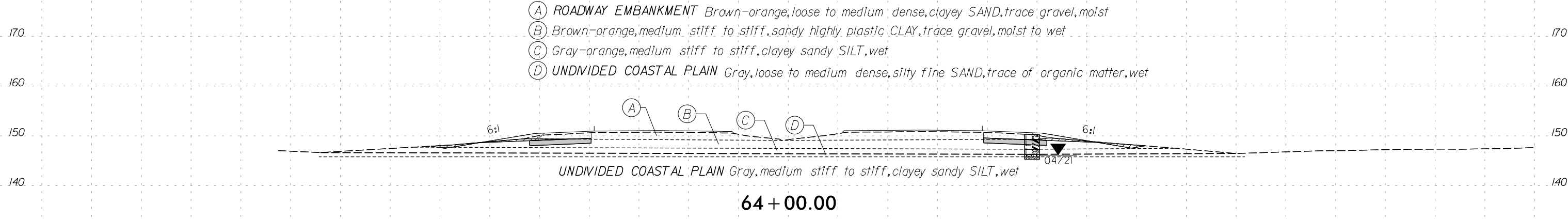
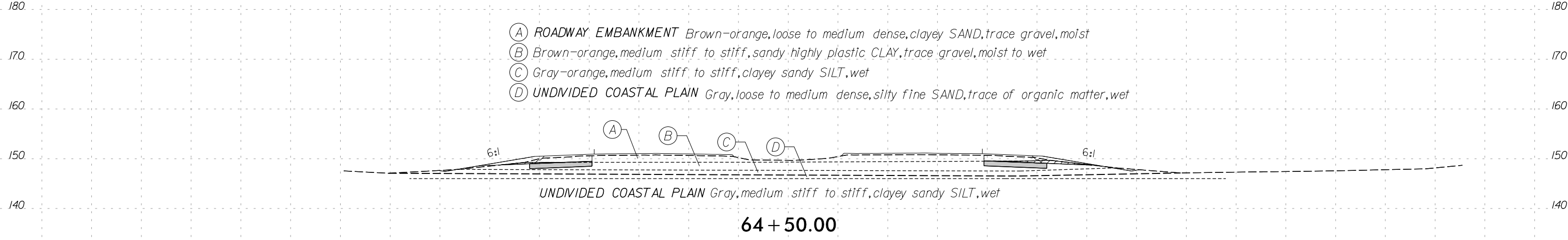

150 140 130 120 110 100 90 80 70 60 50 40 30 20 10 0 10 20 30 40 50 60 70 80 90 100 110 120 130 140 150

190 180 170 160 150 140 130 120 110 100 90 80 70 60 50 40 30 20 10 0 10 20 30 40 50 60 70 80 90 100 110 120 130 140 150

SOIL TEST RESULTS															
SAMPLE NO.	STATION	OFFSET	DEPTH INTERVAL	AASHTO CLASS.	L.L.	P.I.	% BY WEIGHT				% PASSING SIEVE			% MOISTURE	% ORGANIC
							C. SAND	F. SAND	SILT	CLAY	10	40	200		
SS-208	65+79	66' LT	3.5-5.0	A-4 (2)	23	6	10	26	40	24	98	92	71.6	18.3	-

- (A) ROADWAY EMBANKMENT Brown, loose to medium dense, silty SAND, moist
- (B) Brown to brown-orange, medium stiff, sandy to sandy silty highly plastic CLAY, trace gravel, moist to wet

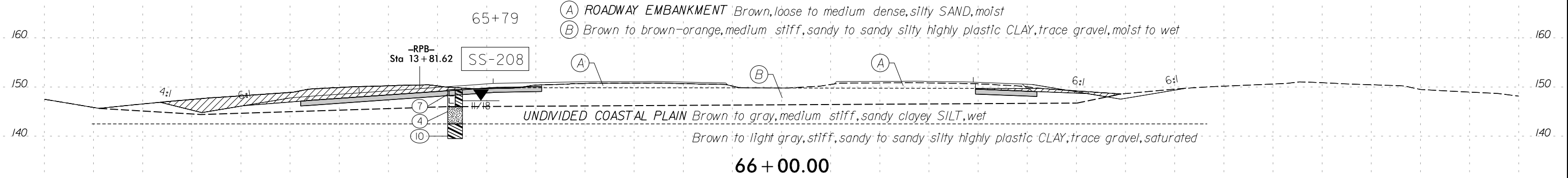

- (A) ROADWAY EMBANKMENT Brown, loose to medium dense, silty SAND, moist
- (B) Brown to brown-orange, medium stiff, sandy to sandy silty highly plastic CLAY, trace gravel, moist to wet

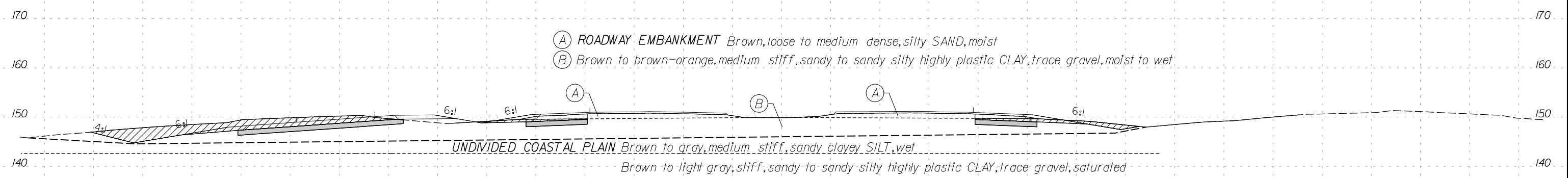

UNCLASSIFIED EXCAVATION - UNSUITABLE WASTE FOR -RPB- CONTINUES ON SHEET 71

SHALLOW UNDERCUT EXCAVATION FOR -RPB- CONTINUES ON SHEET 71

- (A) ROADWAY EMBANKMENT Brown, loose to medium dense, silty SAND, moist
- (B) Brown to brown-orange, medium stiff, sandy to sandy silty highly plastic CLAY, trace gravel, moist to wet

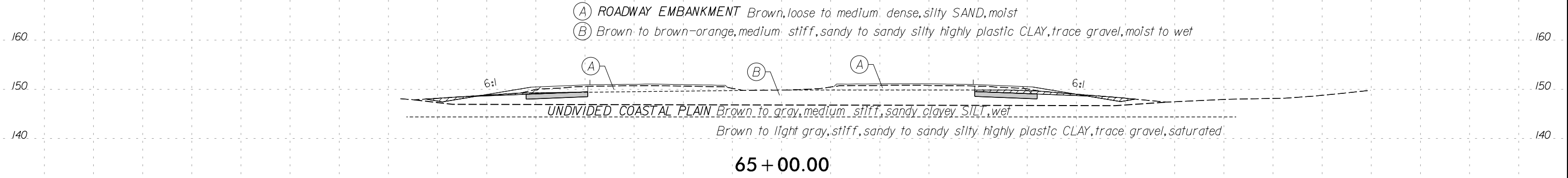

150 140 130 120 110 100 90 80 70 60 50 40 30 20 10 0 10 20 30 40 50 60 70 80 90 100 110 120 130 140 150

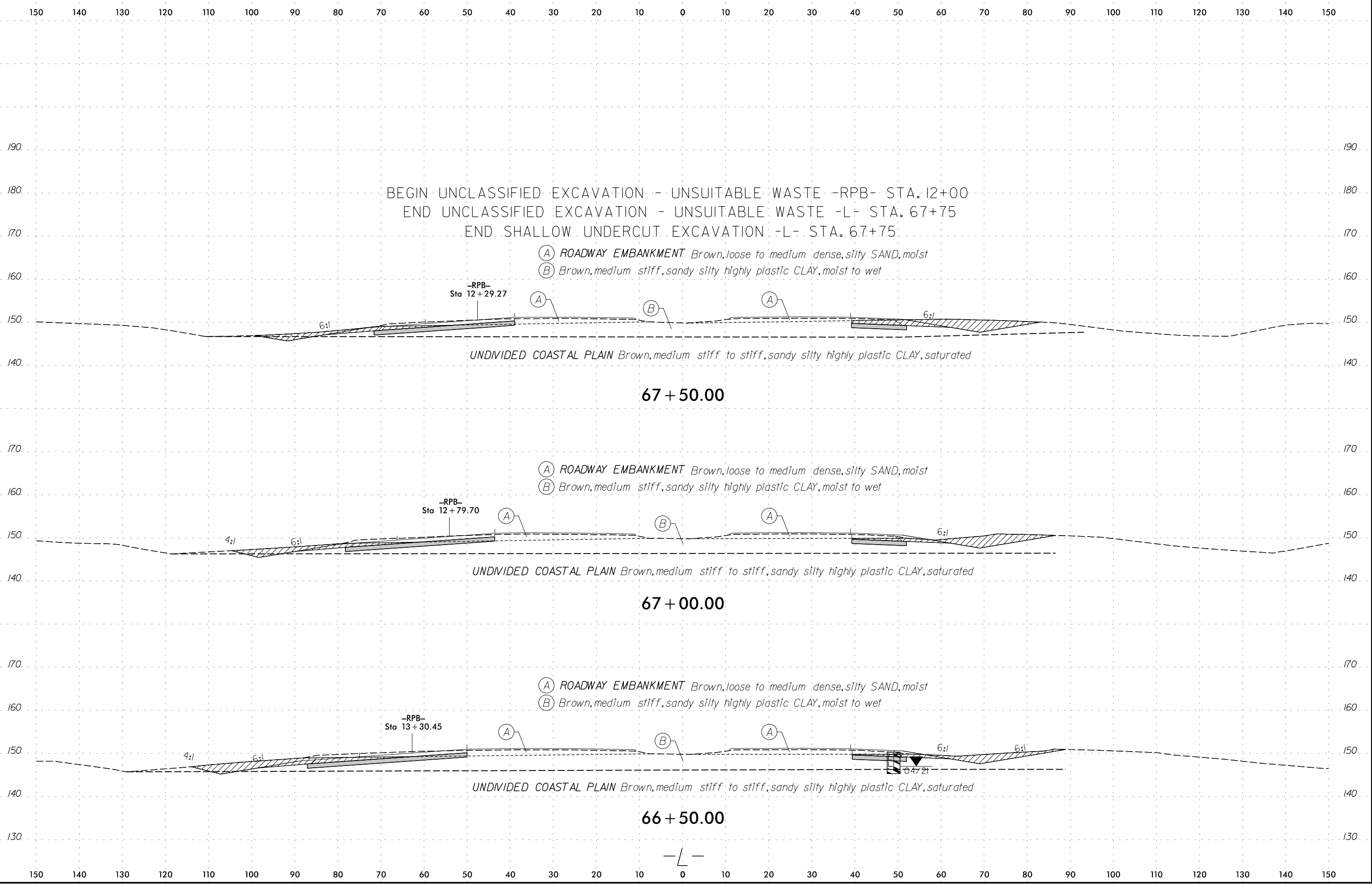

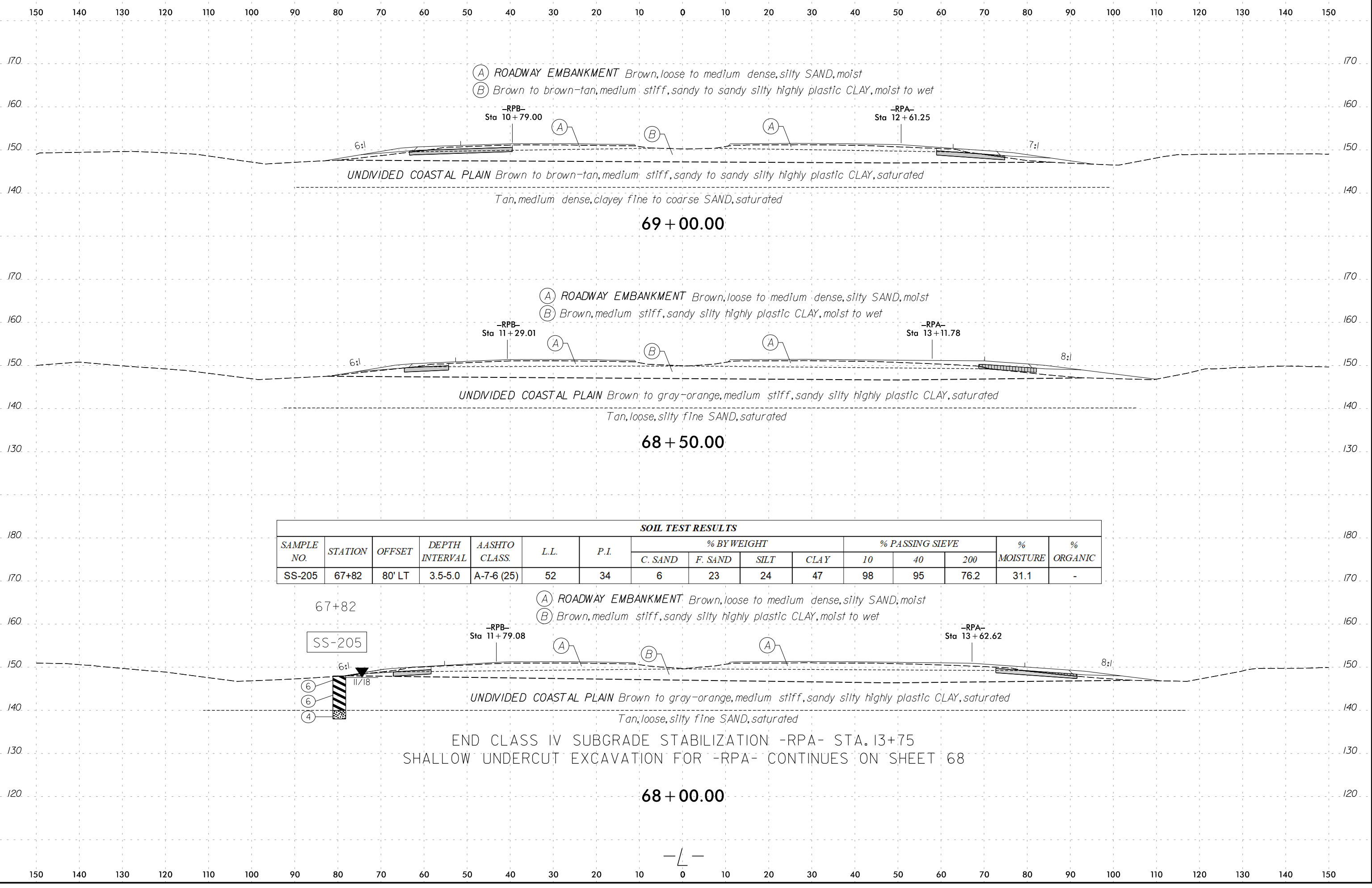

SOIL TEST RESULTS

SAMPLE NO.	STATION	OFFSET	DEPTH INTERVAL	AASHTO CLASS.	L.L.	P.I.	% BY WEIGHT				% PASSING SIEVE			% MOISTURE	% ORGANIC
							C. SAND	F. SAND	SILT	CLAY	10	40	200		
SS-205	67+82	80' LT	3.5-5.0	A-7-6 (25)	52	34	6	23	24	47	98	95	76.2	31.1	-

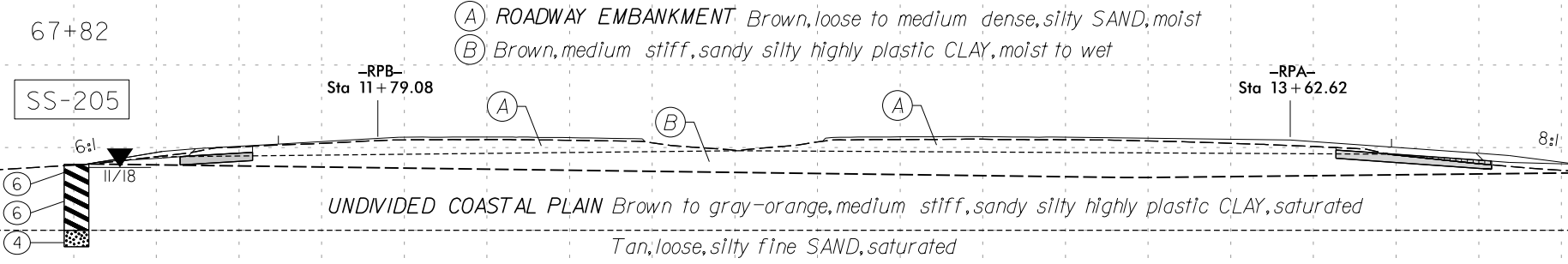

END CLASS IV SUBGRADE STABILIZATION -RPA- STA. 13+75
 SHALLOW UNDERCUT EXCAVATION FOR -RPA- CONTINUES ON SHEET 68

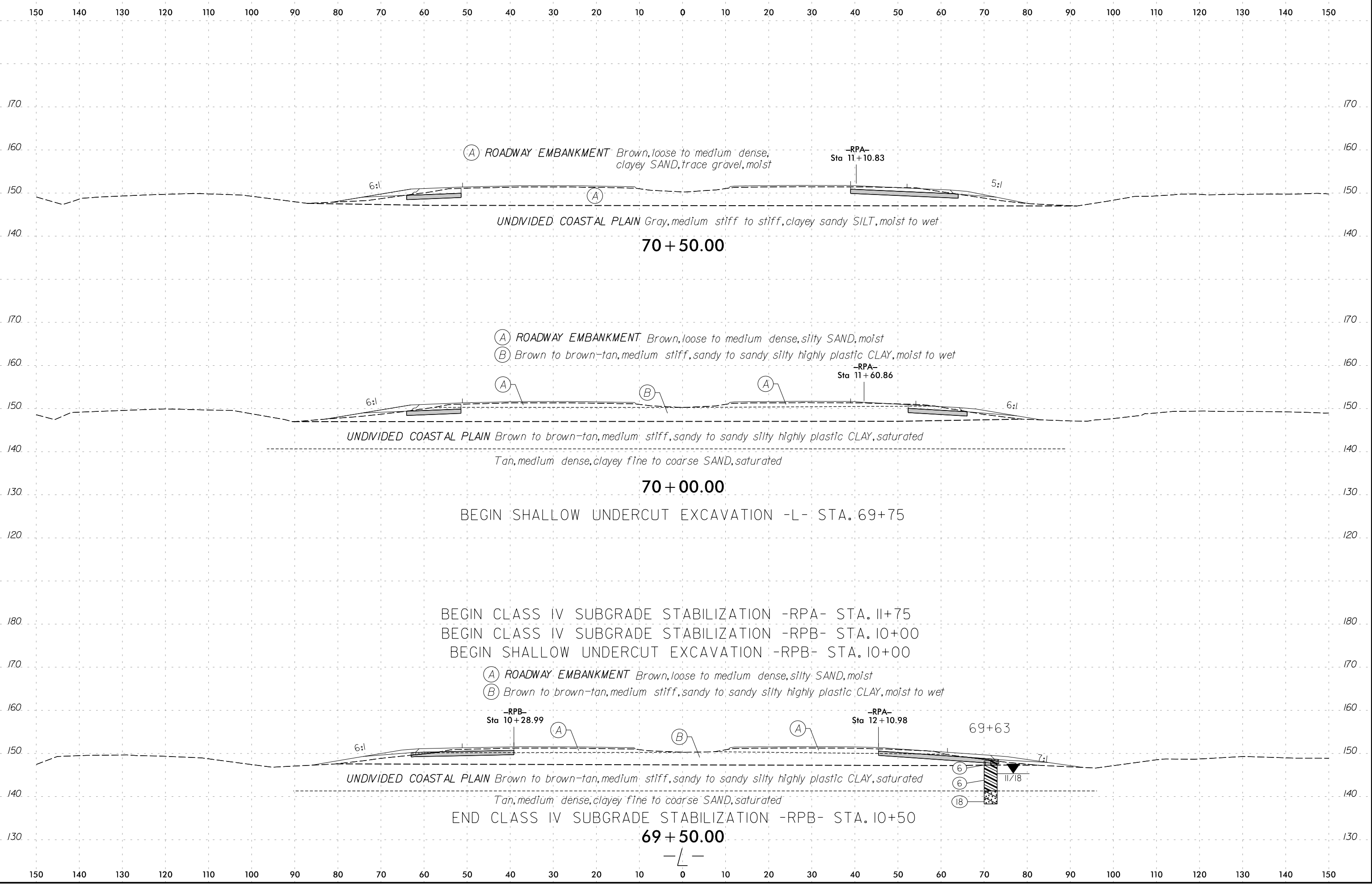

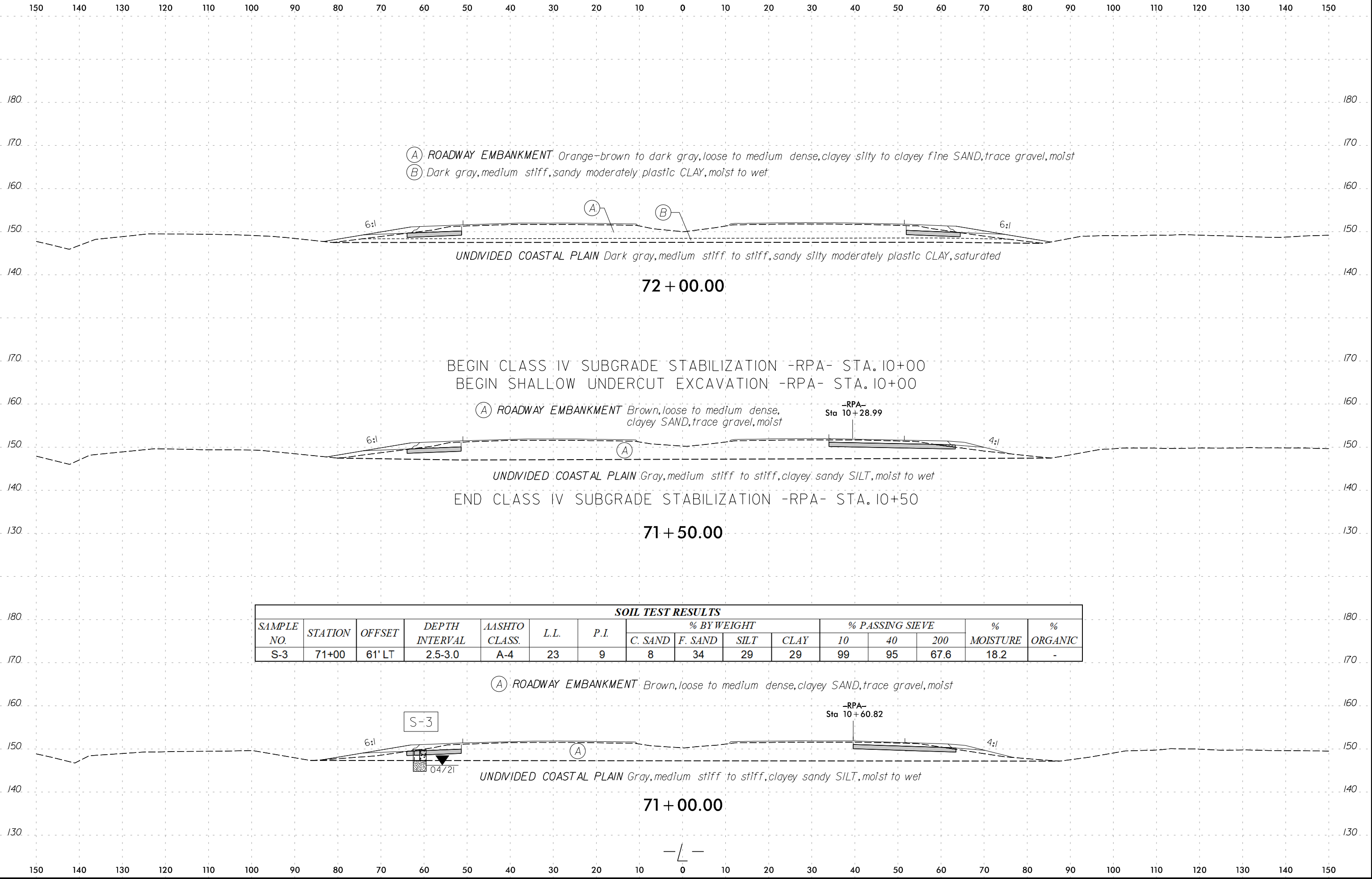

(A) ROADWAY EMBANKMENT Orange-brown to dark gray, loose to medium dense, clayey silty to clayey fine SAND, trace gravel, moist
 (B) Dark gray, medium stiff, sandy moderately plastic CLAY, moist to wet

UNDIVIDED COASTAL PLAIN Dark gray, medium stiff to stiff, sandy silty moderately plastic CLAY, saturated

72 + 00.00

BEGIN CLASS IV SUBGRADE STABILIZATION -RPA- STA. 10+00
 BEGIN SHALLOW UNDERCUT EXCAVATION -RPA- STA. 10+00

(A) ROADWAY EMBANKMENT Brown, loose to medium dense, clayey SAND, trace gravel, moist

-RPA- Sta 10+28.99

UNDIVIDED COASTAL PLAIN Gray, medium stiff to stiff, clayey sandy SILT, moist to wet

END CLASS IV SUBGRADE STABILIZATION -RPA- STA. 10+50

71 + 50.00

SOIL TEST RESULTS															
SAMPLE NO.	STATION	OFFSET	DEPTH INTERVAL	AASHTO CLASS.	L.L.	P.I.	% BY WEIGHT				% PASSING SIEVE			% MOISTURE	% ORGANIC
							C. SAND	F. SAND	SILT	CLAY	10	40	200		
S-3	71+00	61' LT	2.5-3.0	A-4	23	9	8	34	29	29	99	95	67.6	18.2	-

(A) ROADWAY EMBANKMENT Brown, loose to medium dense, clayey SAND, trace gravel, moist

-RPA- Sta 10+60.82

S-3

04/21

UNDIVIDED COASTAL PLAIN Gray, medium stiff to stiff, clayey sandy SILT, moist to wet

71 + 00.00

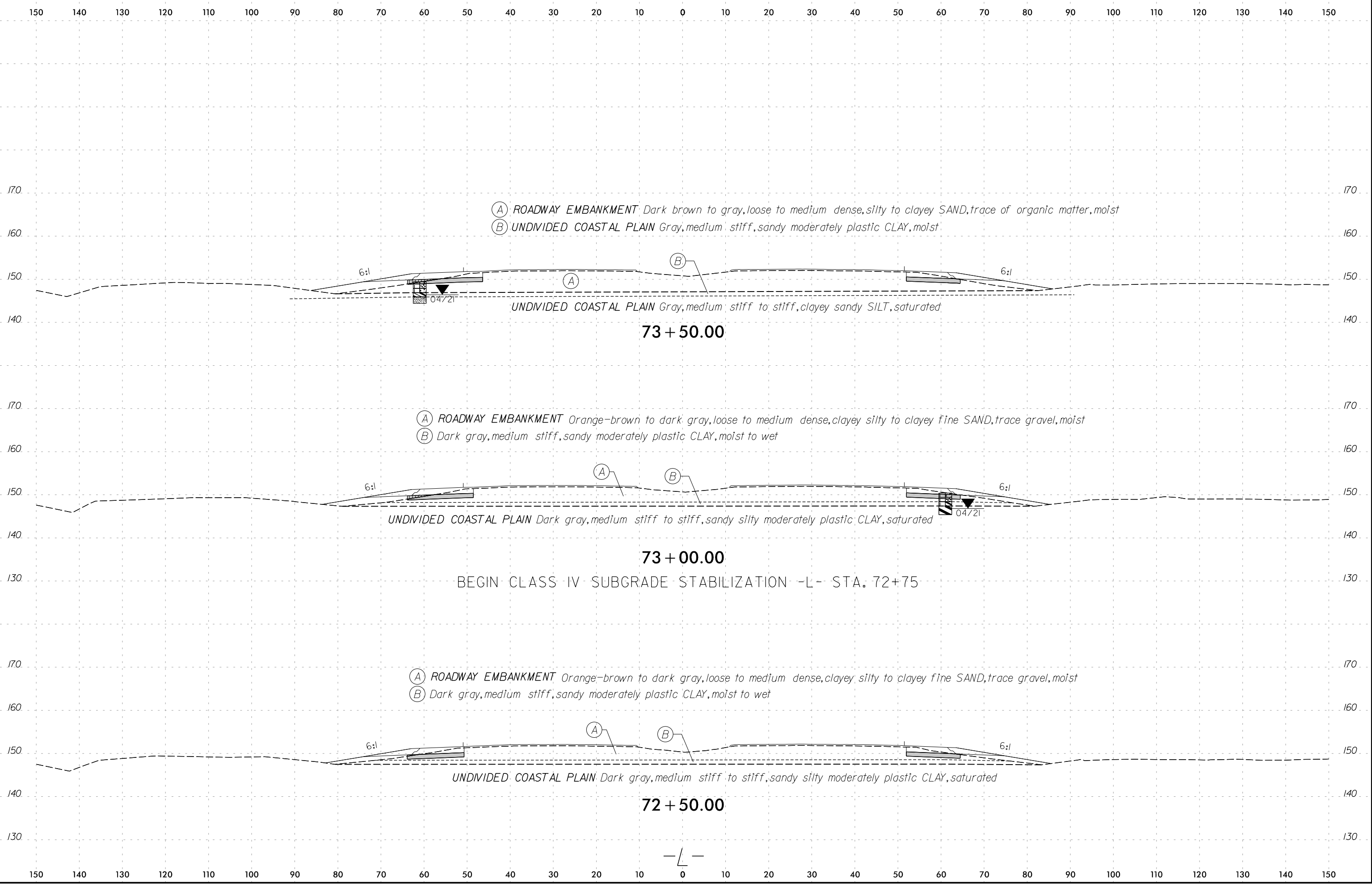

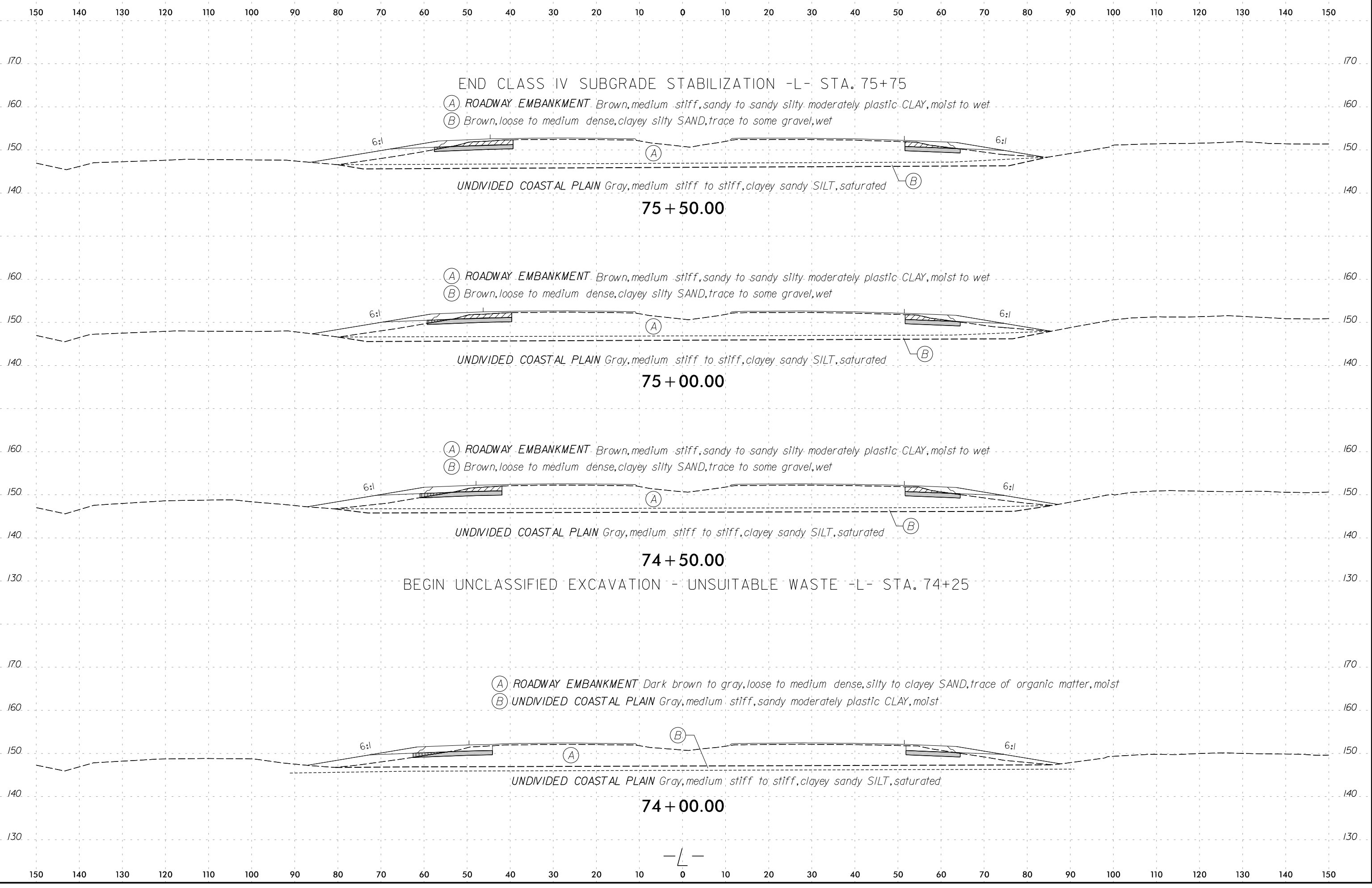

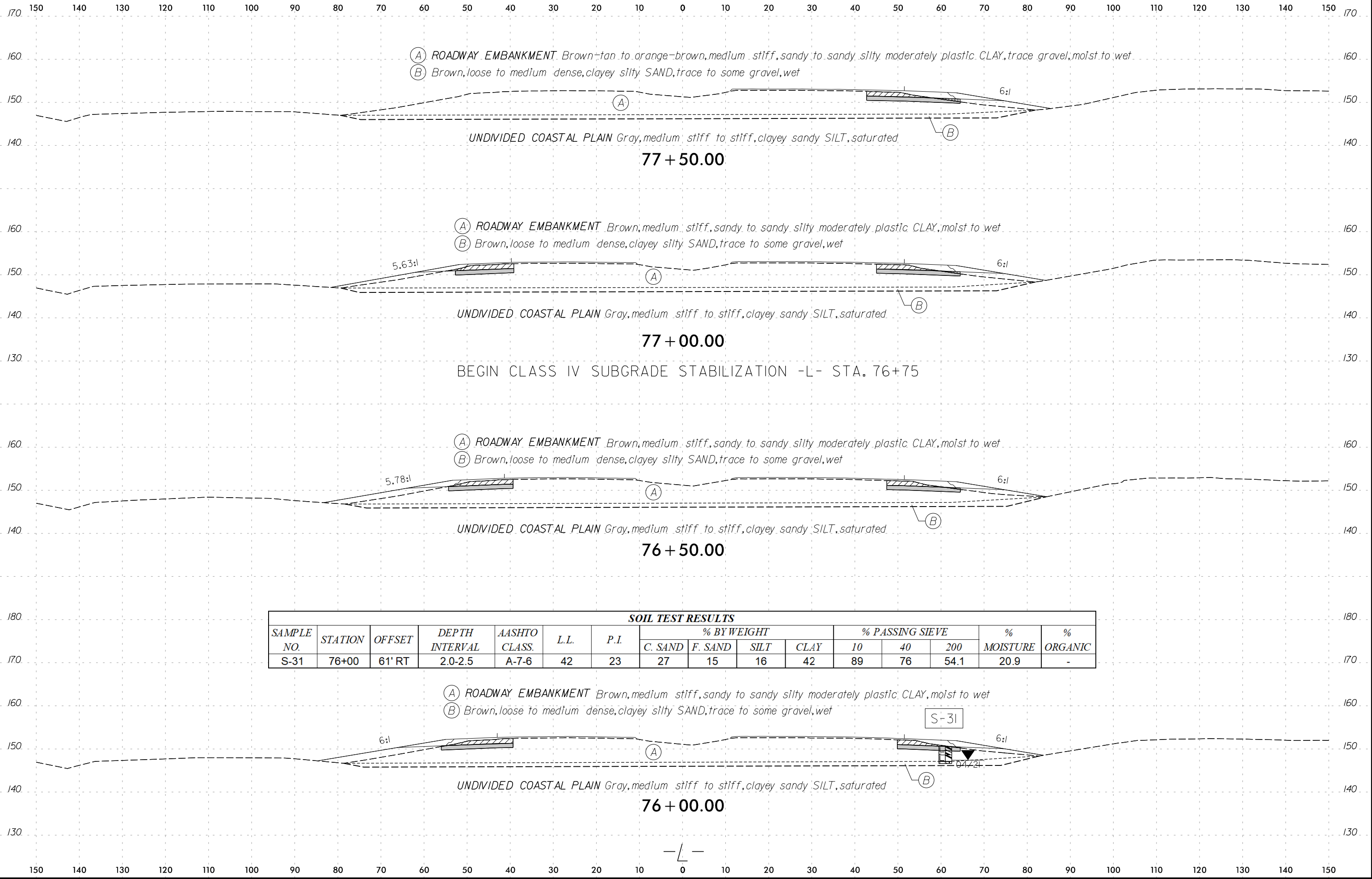

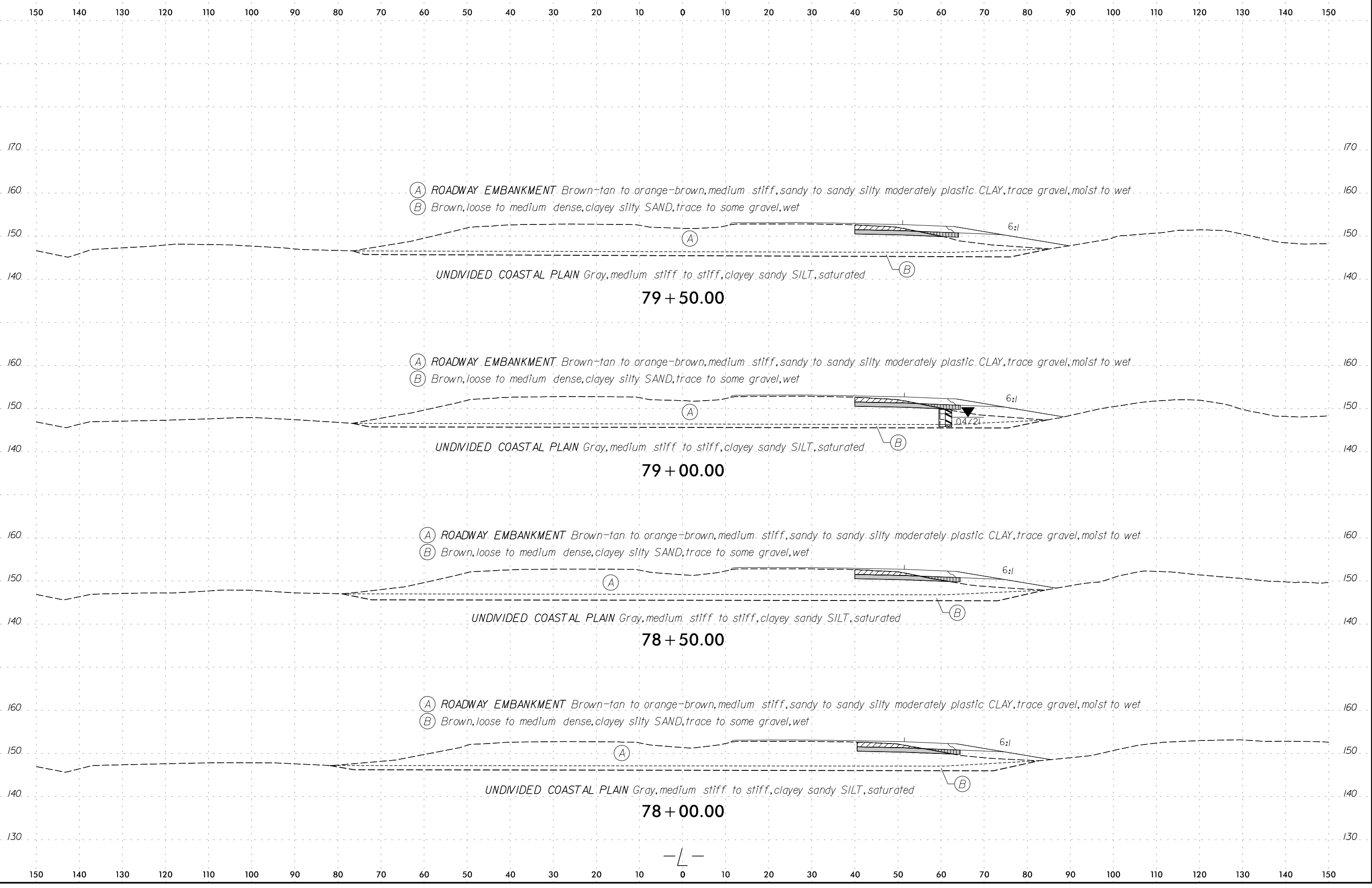

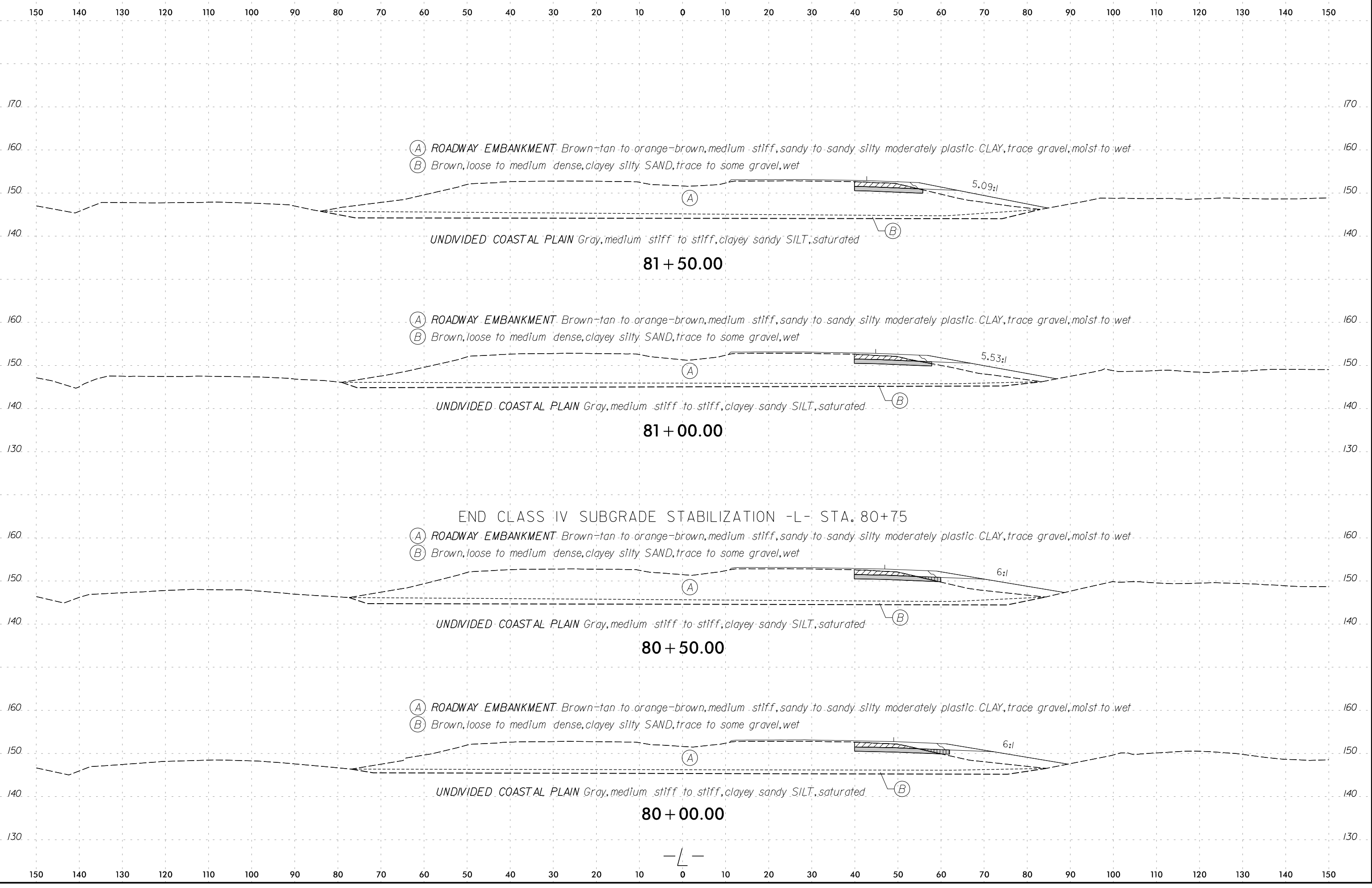

150 140 130 120 110 100 90 80 70 60 50 40 30 20 10 0 10 20 30 40 50 60 70 80 90 100 110 120 130 140 150

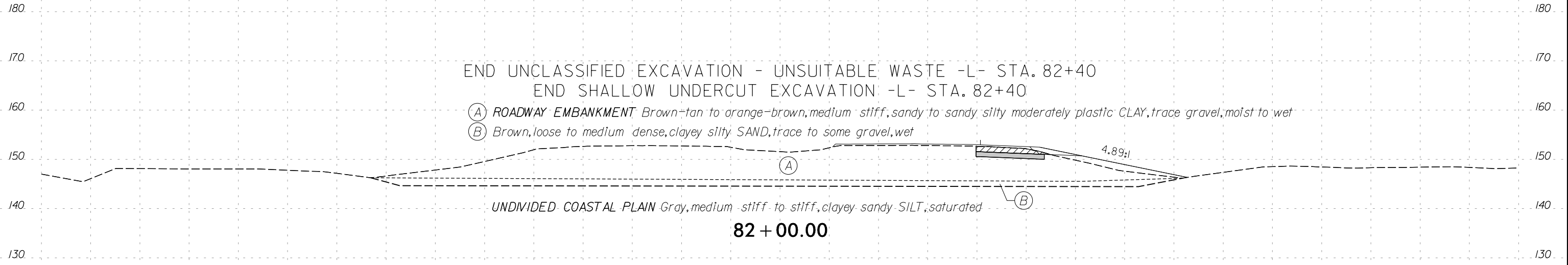

150 140 130 120 110 100 90 80 70 60 50 40 30 20 10 0 10 20 30 40 50 60 70 80 90 100 110 120 130 140 150

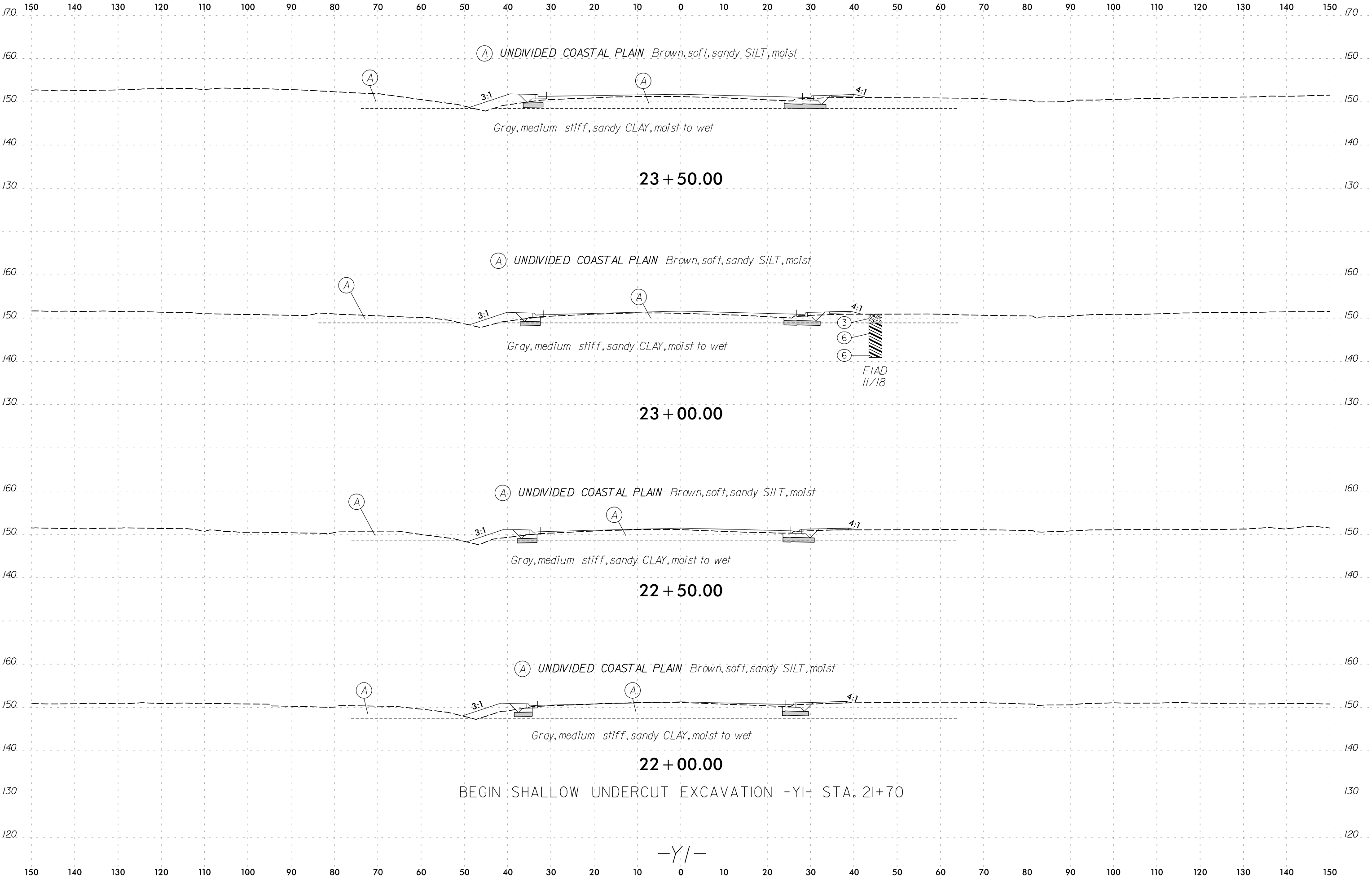

150 140 130 120 110 100 90 80 70 60 50 40 30 20 10 0 10 20 30 40 50 60 70 80 90 100 110 120 130 140 150

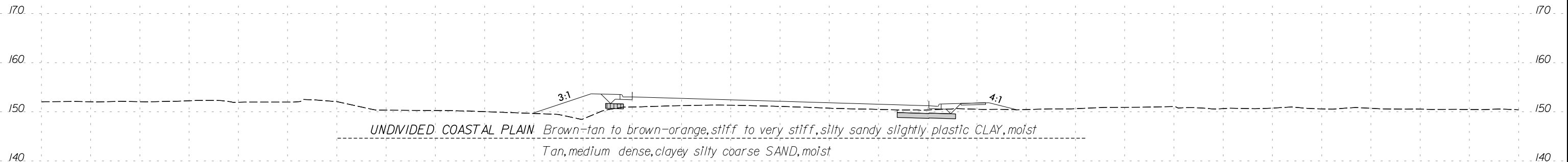

25 + 50.00

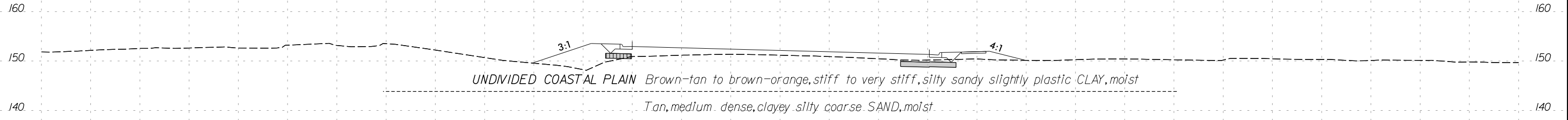

25 + 00.00

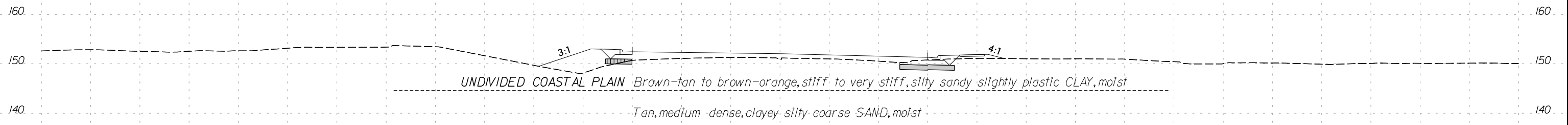

24 + 50.00

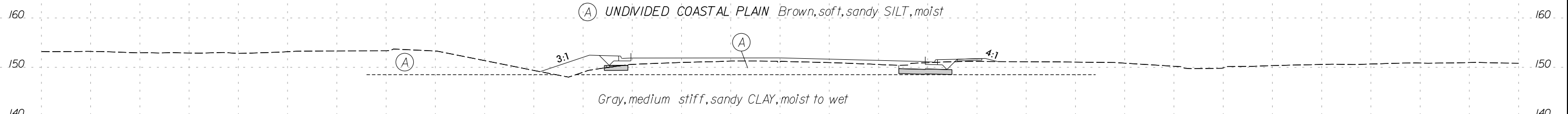

24 + 00.00

BEGIN CLASS IV SUBGRADE STABILIZATION -YI- STA. 23+75

-YI-

150 140 130 120 110 100 90 80 70 60 50 40 30 20 10 0 10 20 30 40 50 60 70 80 90 100 110 120 130 140 150

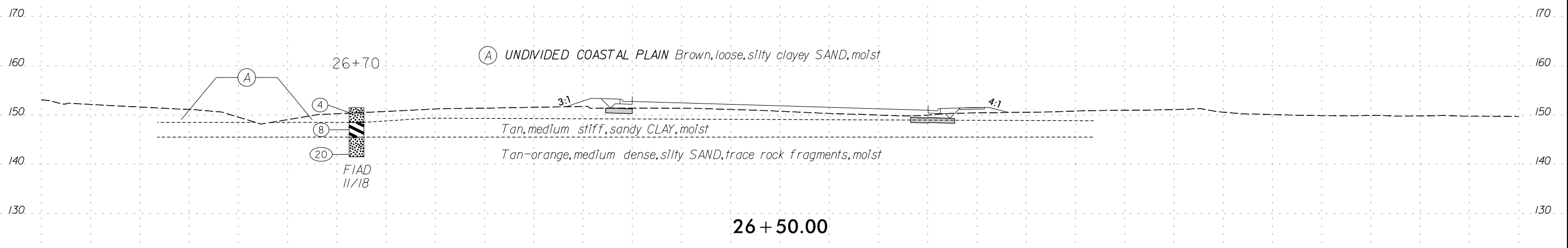
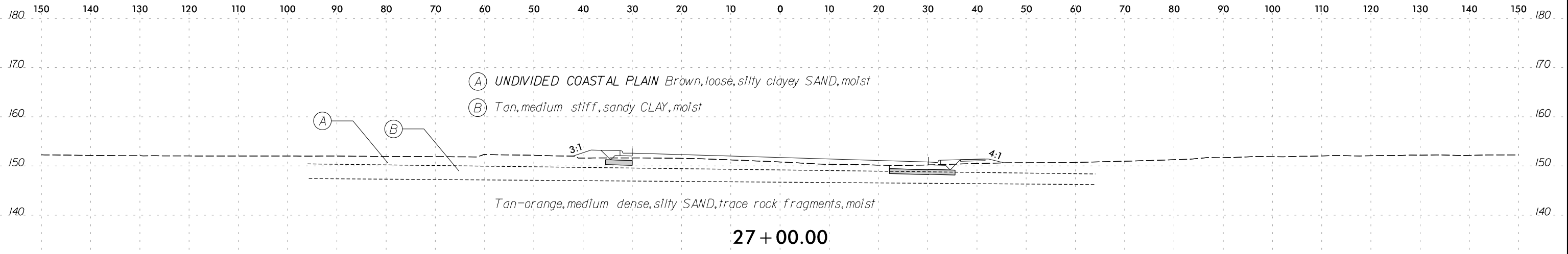

END CLASS IV SUBGRADE STABILIZATION -YI- STA. 26+25

SOIL TEST RESULTS

SAMPLE NO.	STATION	OFFSET	DEPTH INTERVAL	AASHTO CLASS.	L.L.	P.I.	% BY WEIGHT				% PASSING SIEVE			% MOISTURE	% ORGANIC
							C. SAND	F. SAND	SILT	CLAY	10	40	200		
SS-4	25+85	38' RT	0.0-1.5	A-6 (2)	26	11	31	19	24	26	95	76	51.3	13.6	-

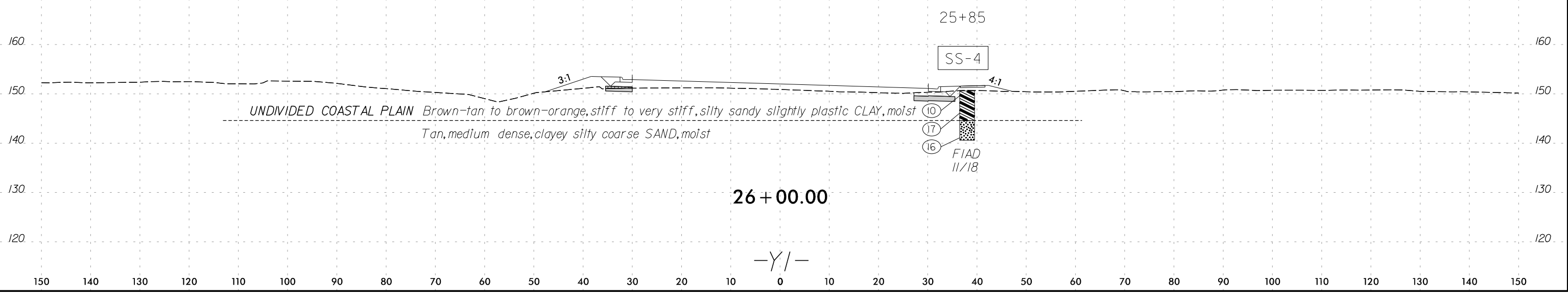

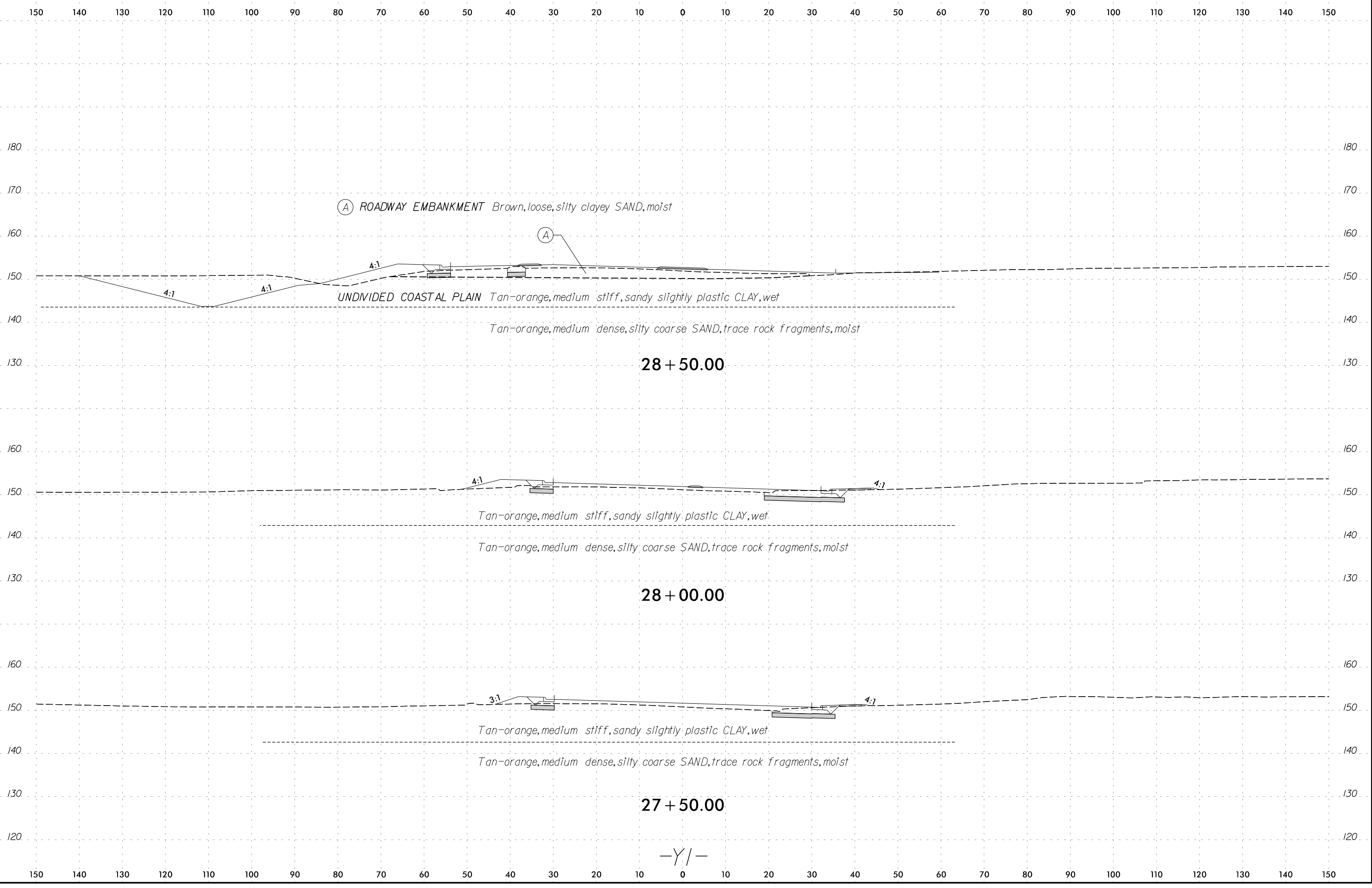

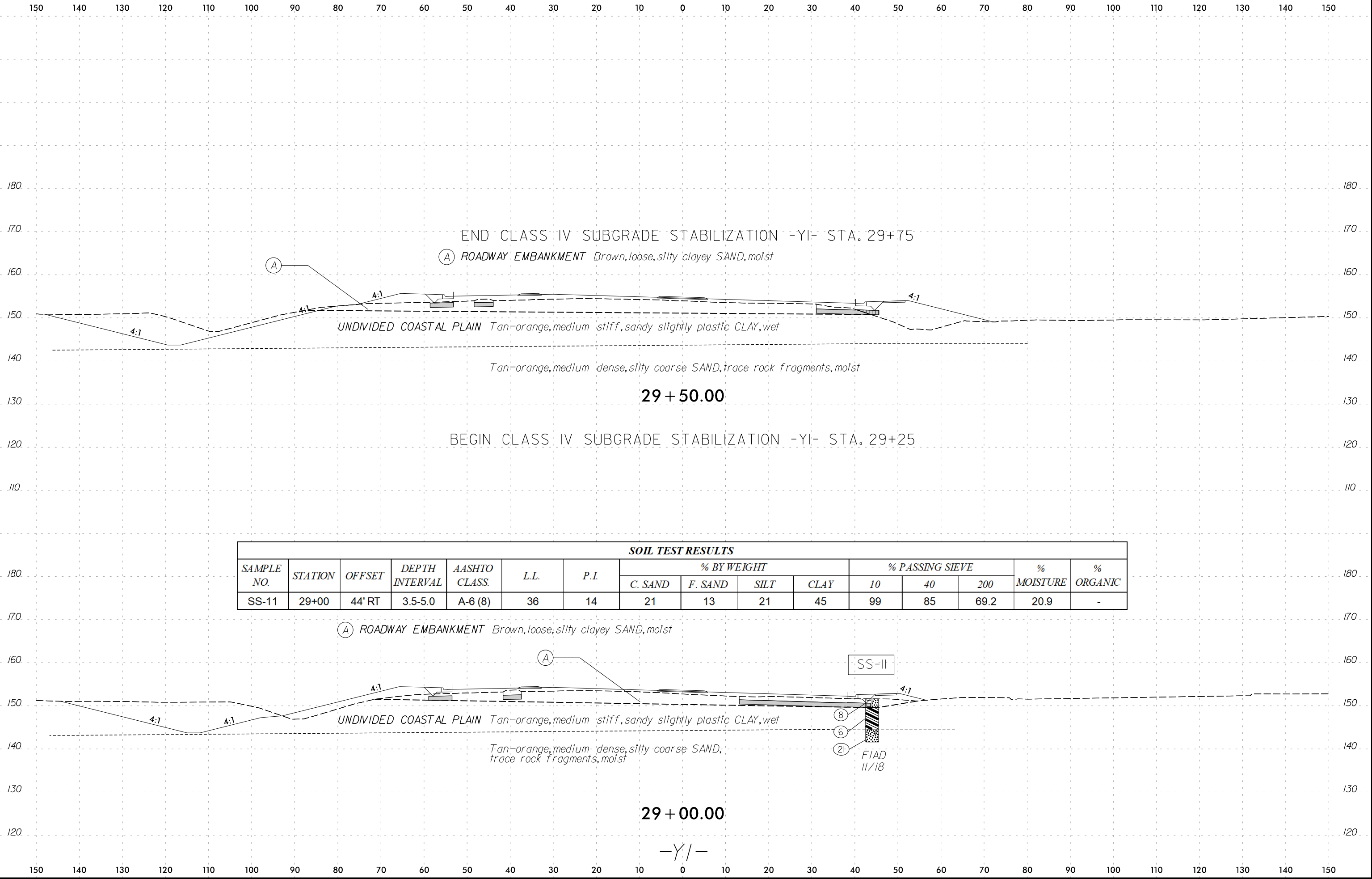

SOIL TEST RESULTS															
SAMPLE NO.	STATION	OFFSET	DEPTH INTERVAL	AASHTO CLASS.	L.L.	P.I.	% BY WEIGHT				% PASSING SIEVE			% MOISTURE	% ORGANIC
							C. SAND	F. SAND	SILT	CLAY	10	40	200		
SS-11	29+00	44' RT	3.5-5.0	A-6 (8)	36	14	21	13	21	45	99	85	69.2	20.9	-

150 140 130 120 110 100 90 80 70 60 50 40 30 20 10 0 10 20 30 40 50 60 70 80 90 100 110 120 130 140 150

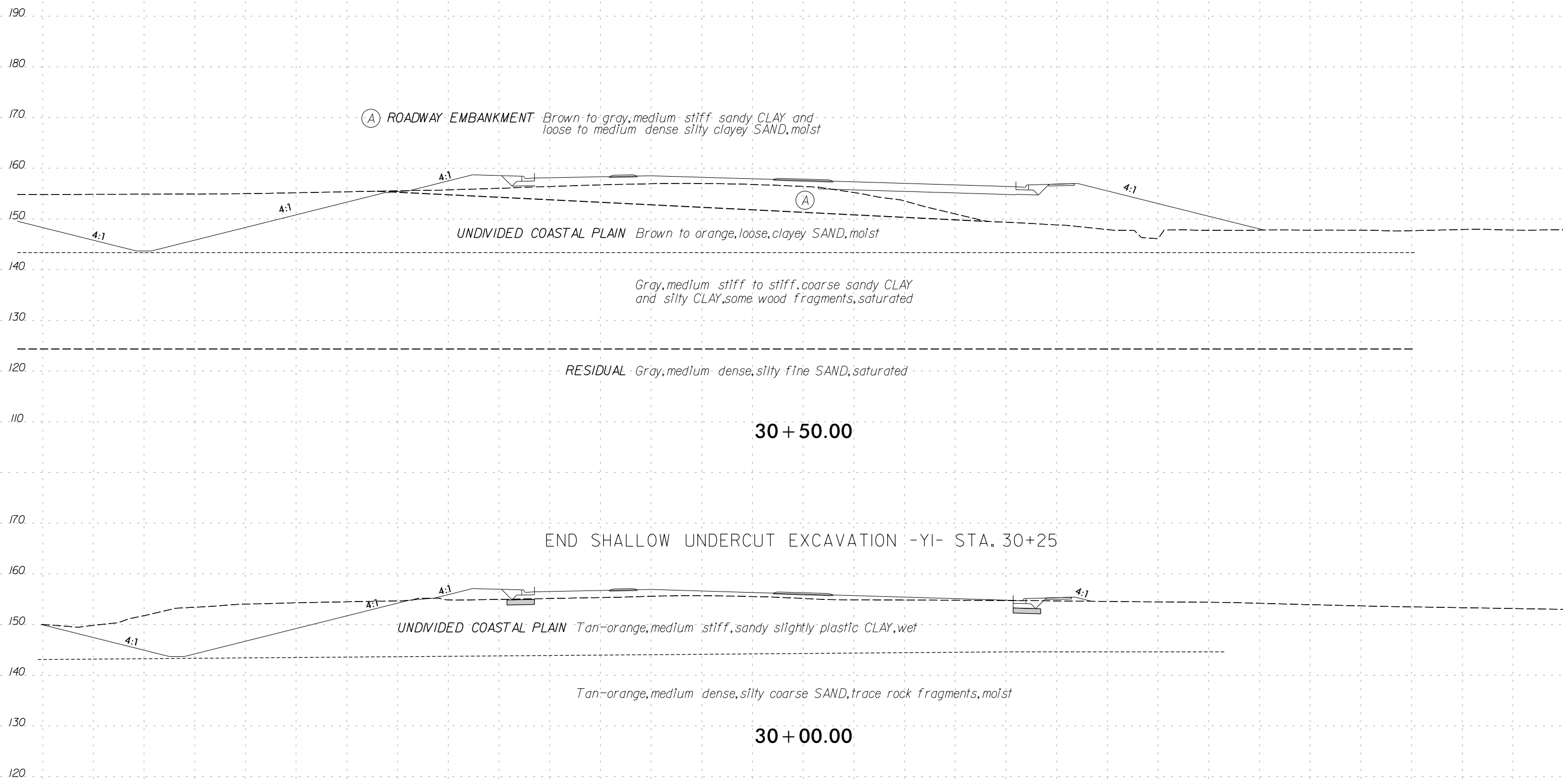

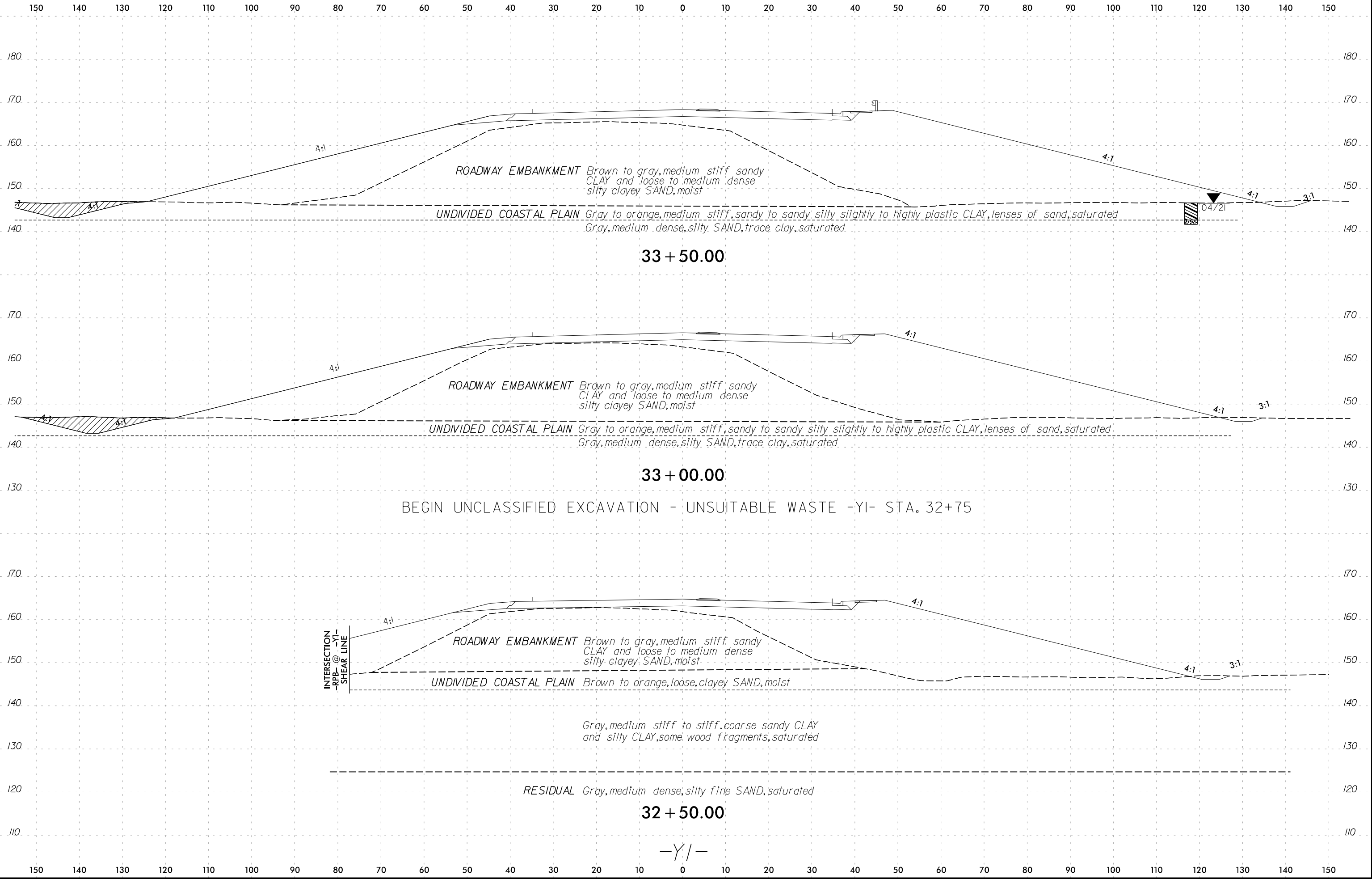
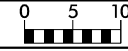

150 140 130 120 110 100 90 80 70 60 50 40 30 20 10 0 10 20 30 40 50 60 70 80 90 100 110 120 130 140 150

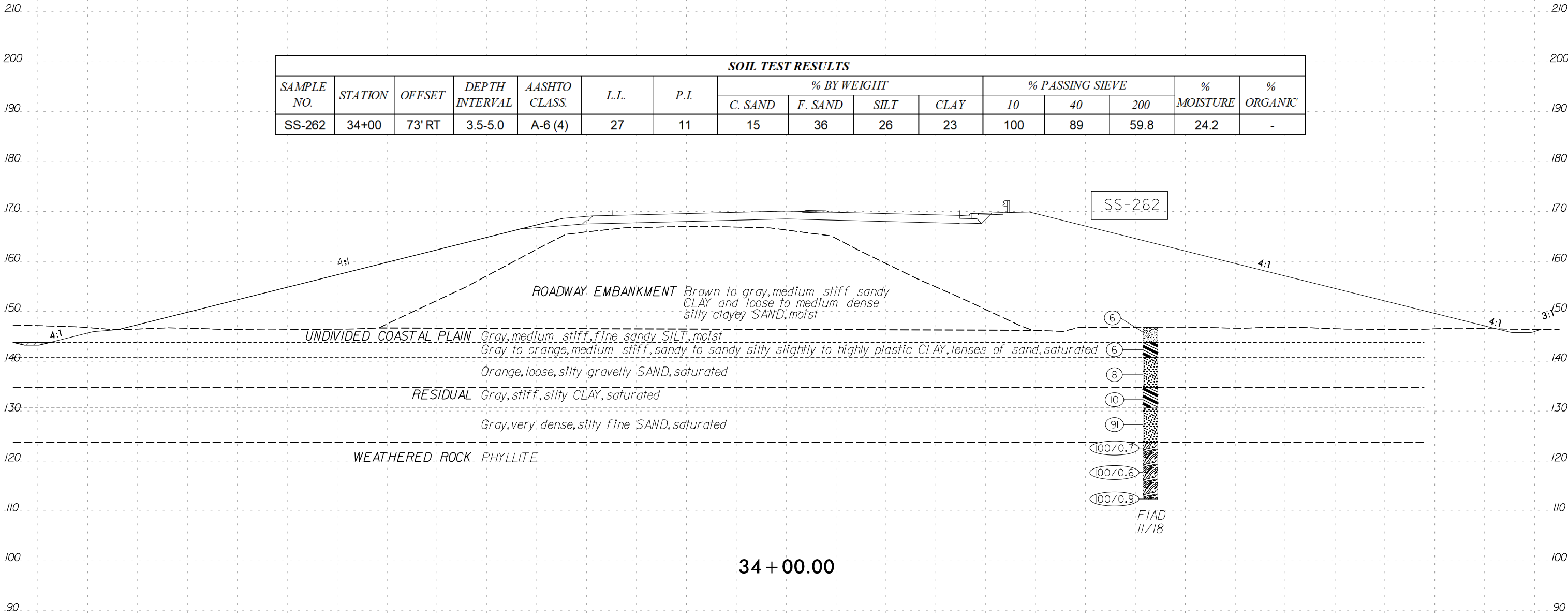

160 150 140 130 120 110 100 90 80 70 60 50 40 30 20 10 0 10 20 30 40 50 60 70 80 90 100 110 120 130 140

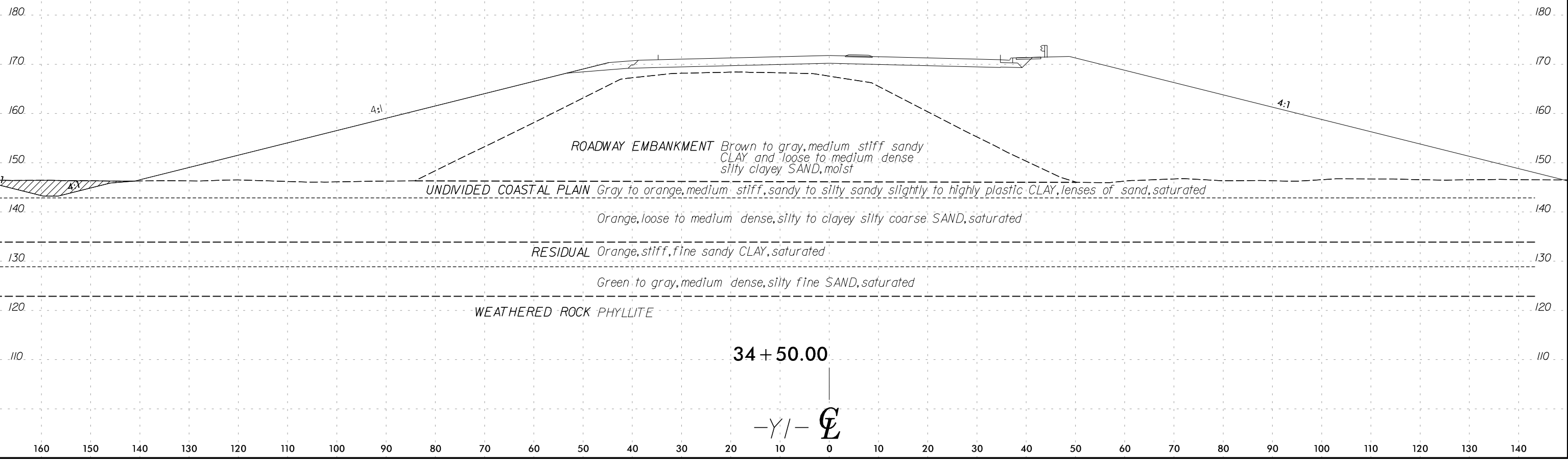

170 160 150 140 130 120 110 100 90 80 70 60 50 40 30 20 10 0 10 20 30 40 50 60 70 80 90 100 110 120 130

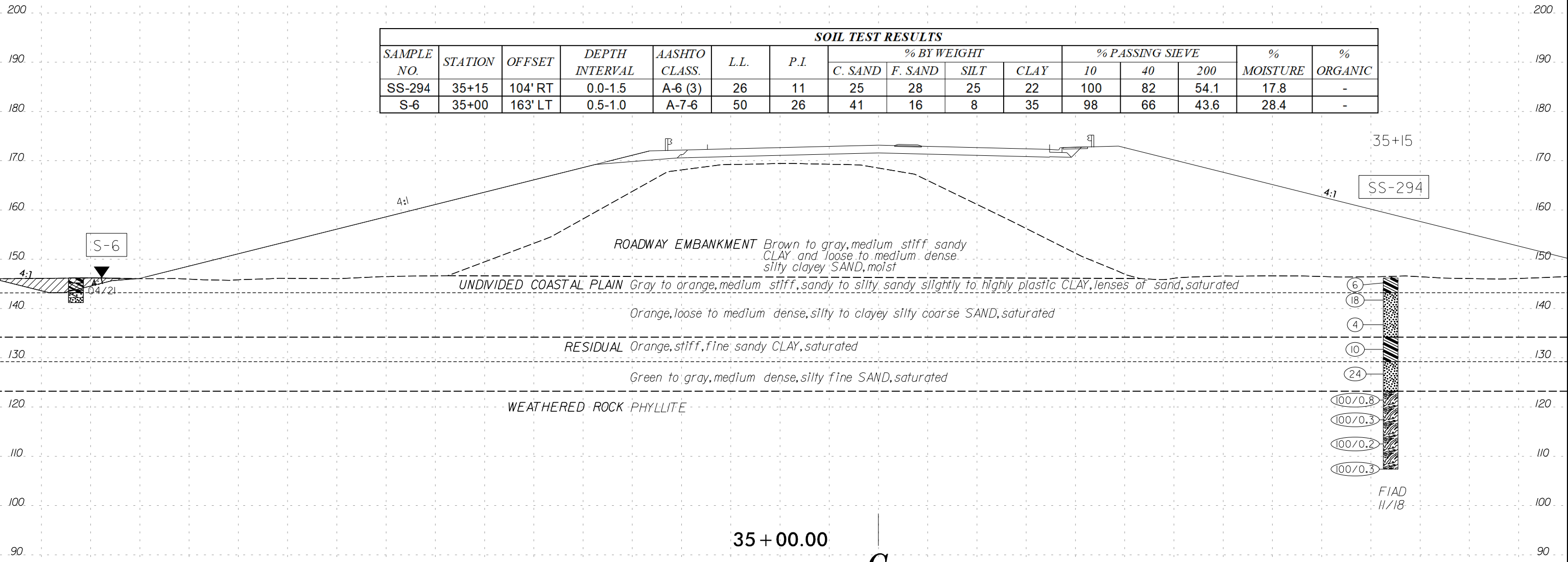

SOIL TEST RESULTS															
SAMPLE NO.	STATION	OFFSET	DEPTH INTERVAL	AASHTO CLASS.	L.L.	P.I.	% BY WEIGHT				% PASSING SIEVE			% MOISTURE	% ORGANIC
							C. SAND	F. SAND	SILT	CLAY	10	40	200		
SS-294	35+15	104' RT	0.0-1.5	A-6 (3)	26	11	25	28	25	22	100	82	54.1	17.8	-
S-6	35+00	163' LT	0.5-1.0	A-7-6	50	26	41	16	8	35	98	66	43.6	28.4	-

9/29/2021
R:\Geotech\Investigation\Design\CADD_GEO\TECH\XSC\Recommendations_graphics\I5972_GEO_XSR_Y1.dgn
mmetrlj

35 + 00.00

-Y/-

CL

170 160 150 140 130 120 110 100 90 80 70 60 50 40 30 20 10 0 10 20 30 40 50 60 70 80 90 100 110 120 130

170 160 150 140 130 120 110 100 90 80 70 60 50 40 30 20 10 0 10 20 30 40 50 60 70 80 90 100 110 120 130

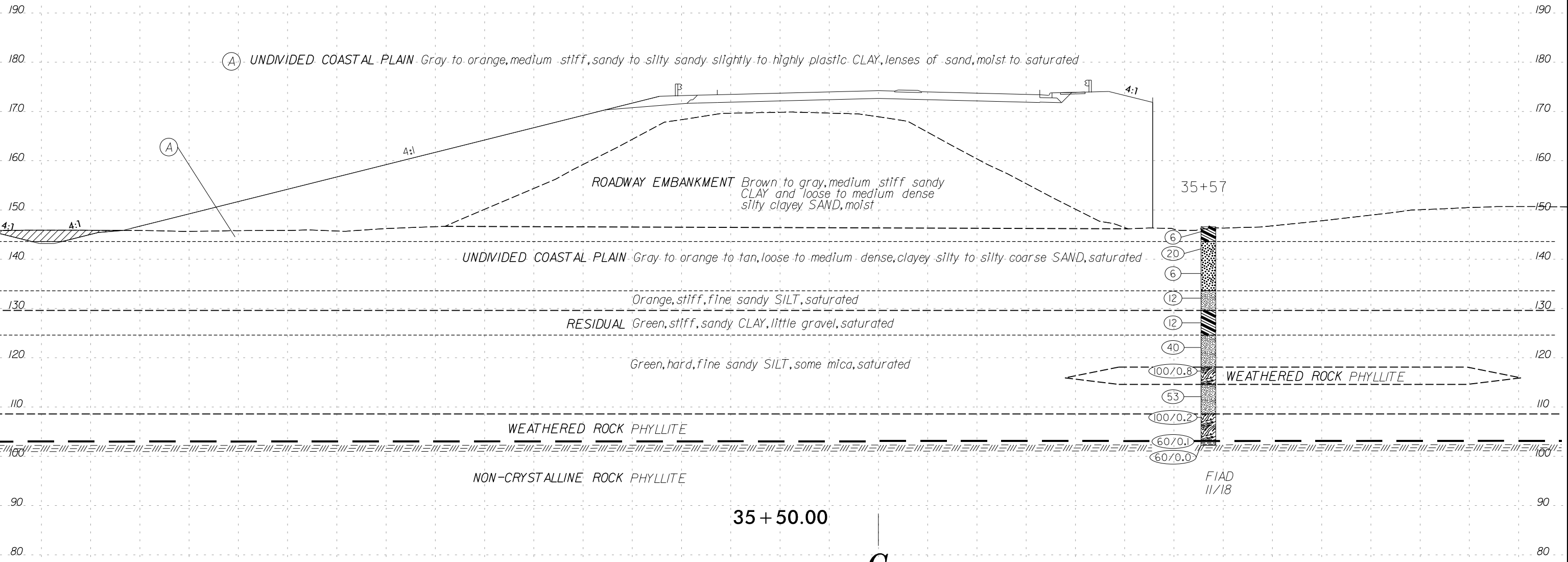

9/29/2021 R:\Geotech\Investigation\Design\CADD_GEO\TECH\XSC\Recommendations_graphics\15972_GEO_XSR_Y1.dgn

170 160 150 140 130 120 110 100 90 80 70 60 50 40 30 20 10 0 10 20 30 40 50 60 70 80 90 100 110 120 130

170 160 150 140 130 120 110 100 90 80 70 60 50 40 30 20 10 0 10 20 30 40 50 60 70 80 90 100 110 120 130

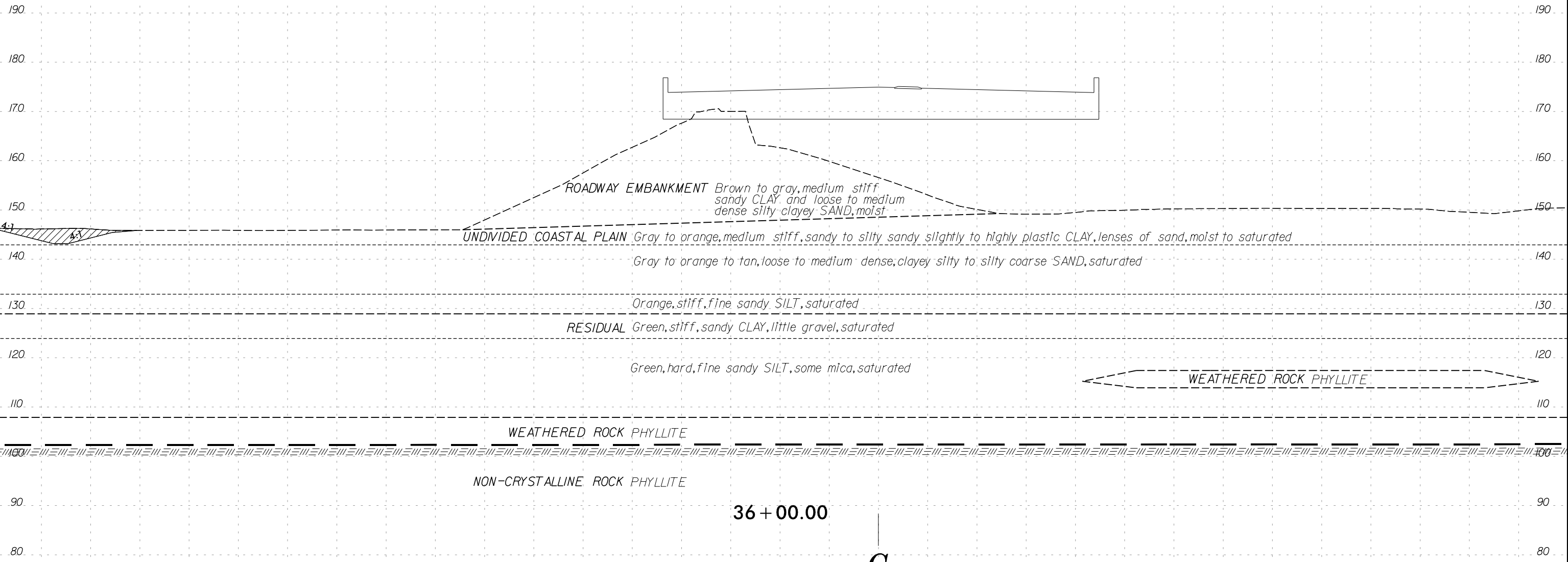

9/29/2021
R:\Geotech\Investigation\Design\CADD_GEO\TECH\XSC\Recommendations_graphics\15972_GEO_XSR_Y1.dgn

170 160 150 140 130 120 110 100 90 80 70 60 50 40 30 20 10 0 10 20 30 40 50 60 70 80 90 100 110 120 130

-Y/-

CL

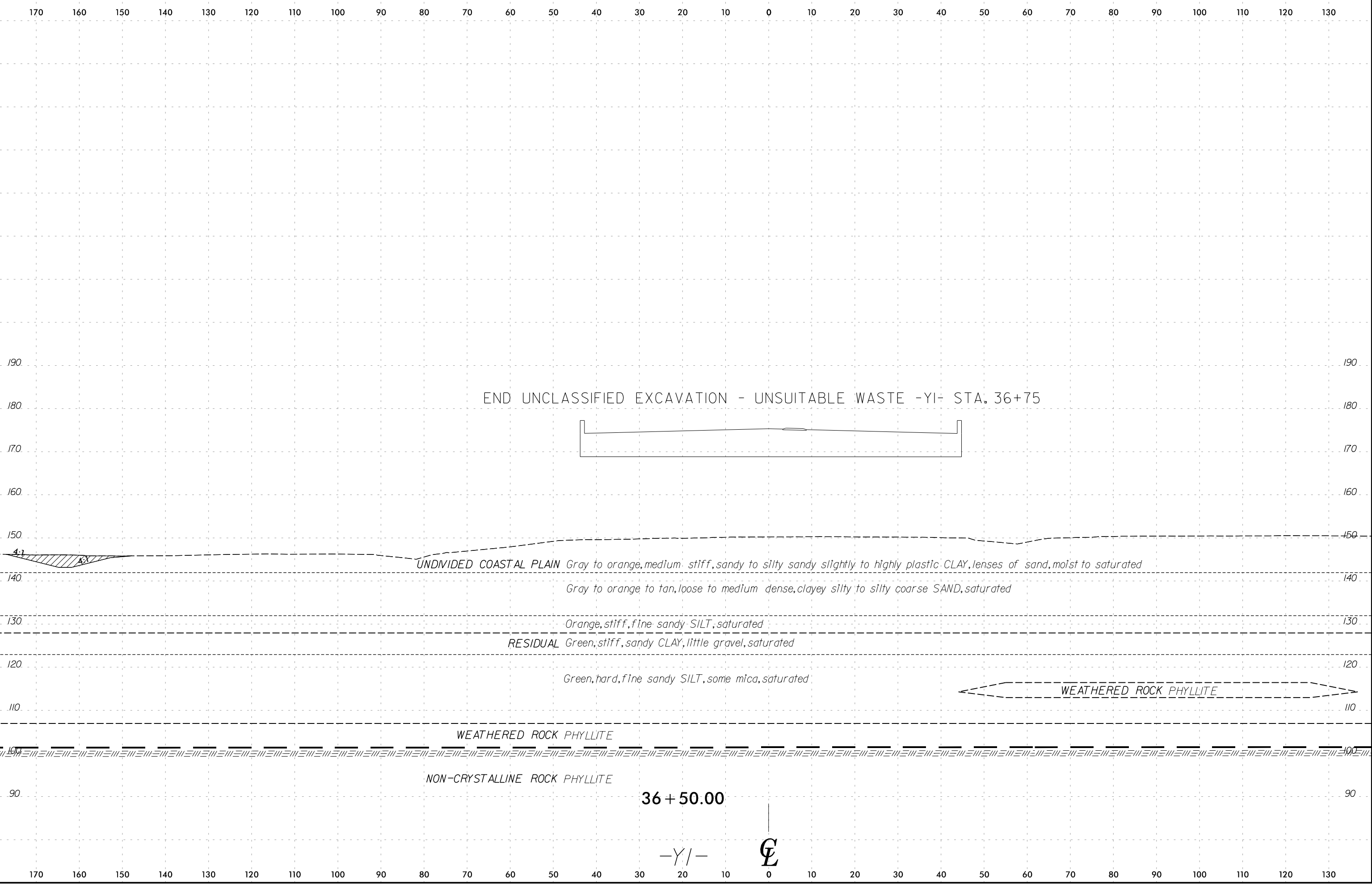

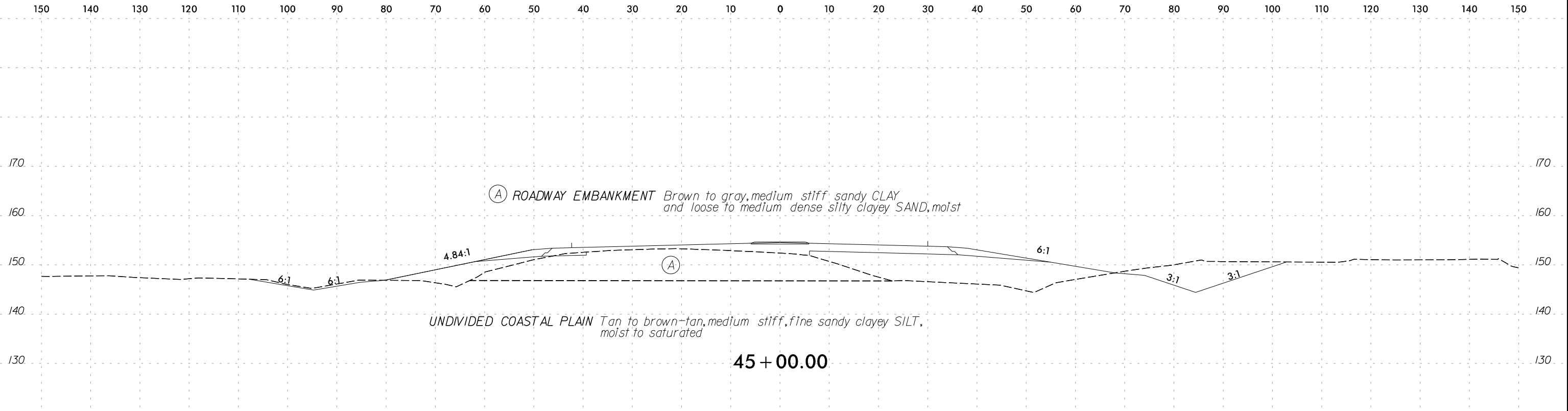

45 + 00.00

SOIL TEST RESULTS															
SAMPLE NO.	STATION	OFFSET	DEPTH INTERVAL	AASHTO CLASS.	L.L.	P.I.	% BY WEIGHT				% PASSING SIEVE			% MOISTURE	% ORGANIC
							C. SAND	F. SAND	SILT	CLAY	10	40	200		
SS-234	36+76	111' LT	0.0-1.5	A-7-6 (5)	45	22	34	28	10	28	99	78	41.4	16.8	-

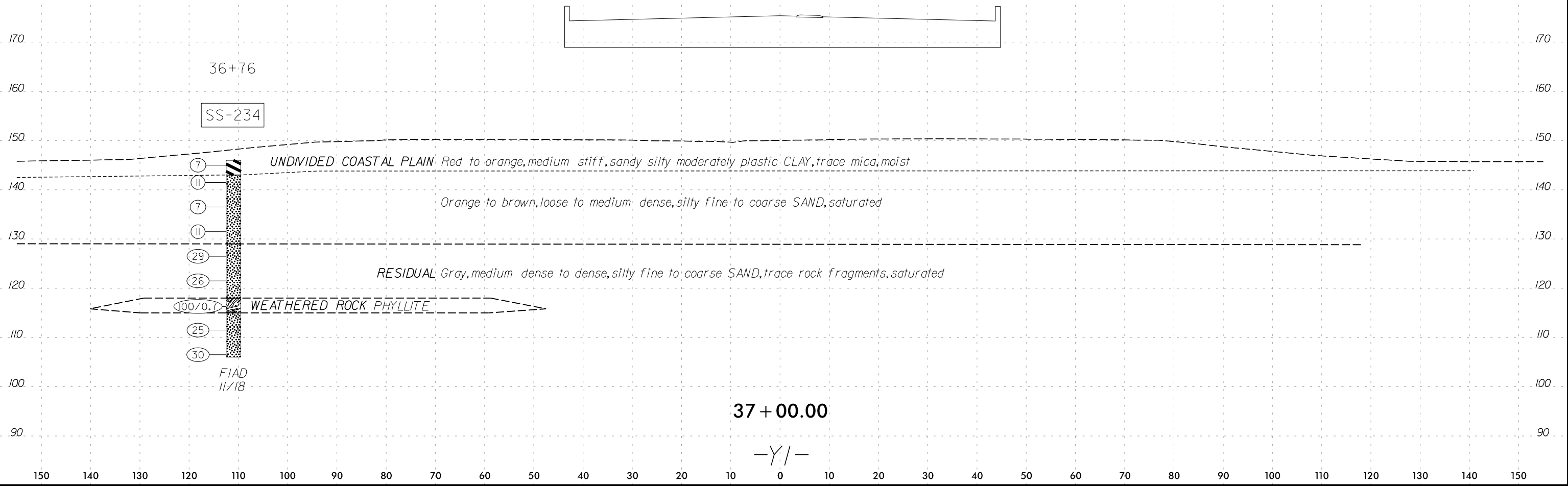

37 + 00.00

-Y/-

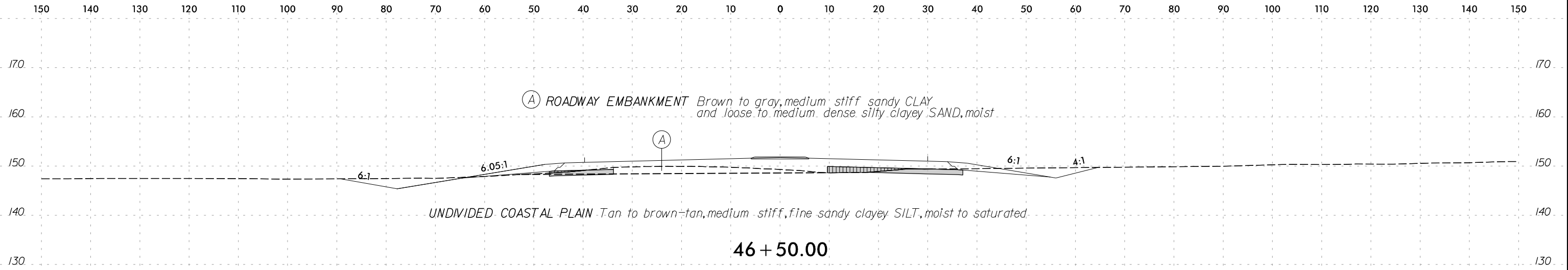

SOIL TEST RESULTS															
SAMPLE NO.	STATION	OFFSET	DEPTH INTERVAL	AASHTO CLASS.	L.L.	P.I.	% BY WEIGHT				% PASSING SIEVE			% MOISTURE	% ORGANIC
							C. SAND	F. SAND	SILT	CLAY	10	40	200		
SS-51	45+85	20' RT	3.5-5.0	A-4 (3)	25	10	19	30	26	25	99	89	55.6	12.2	-

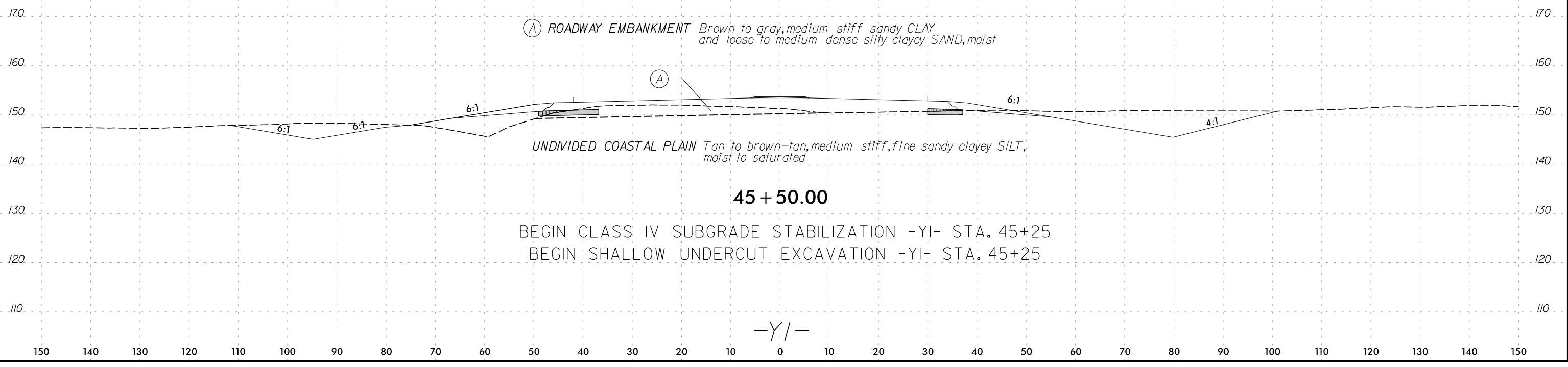
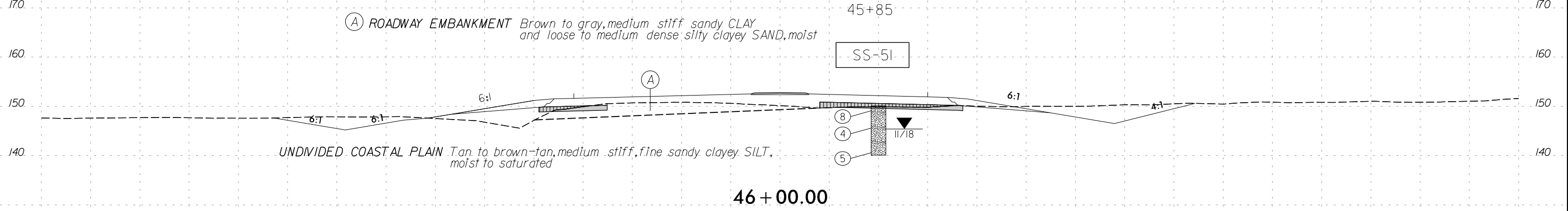

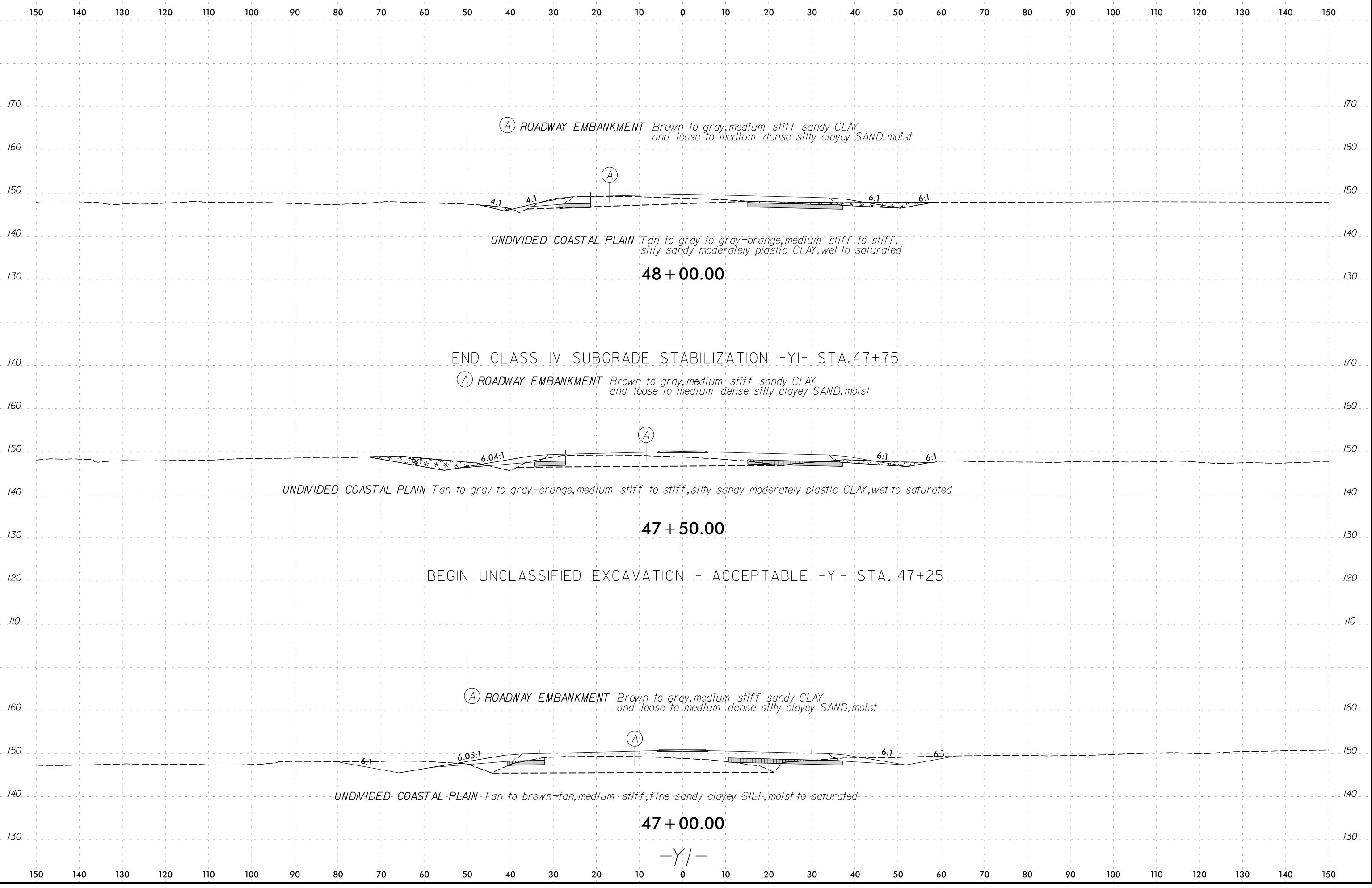

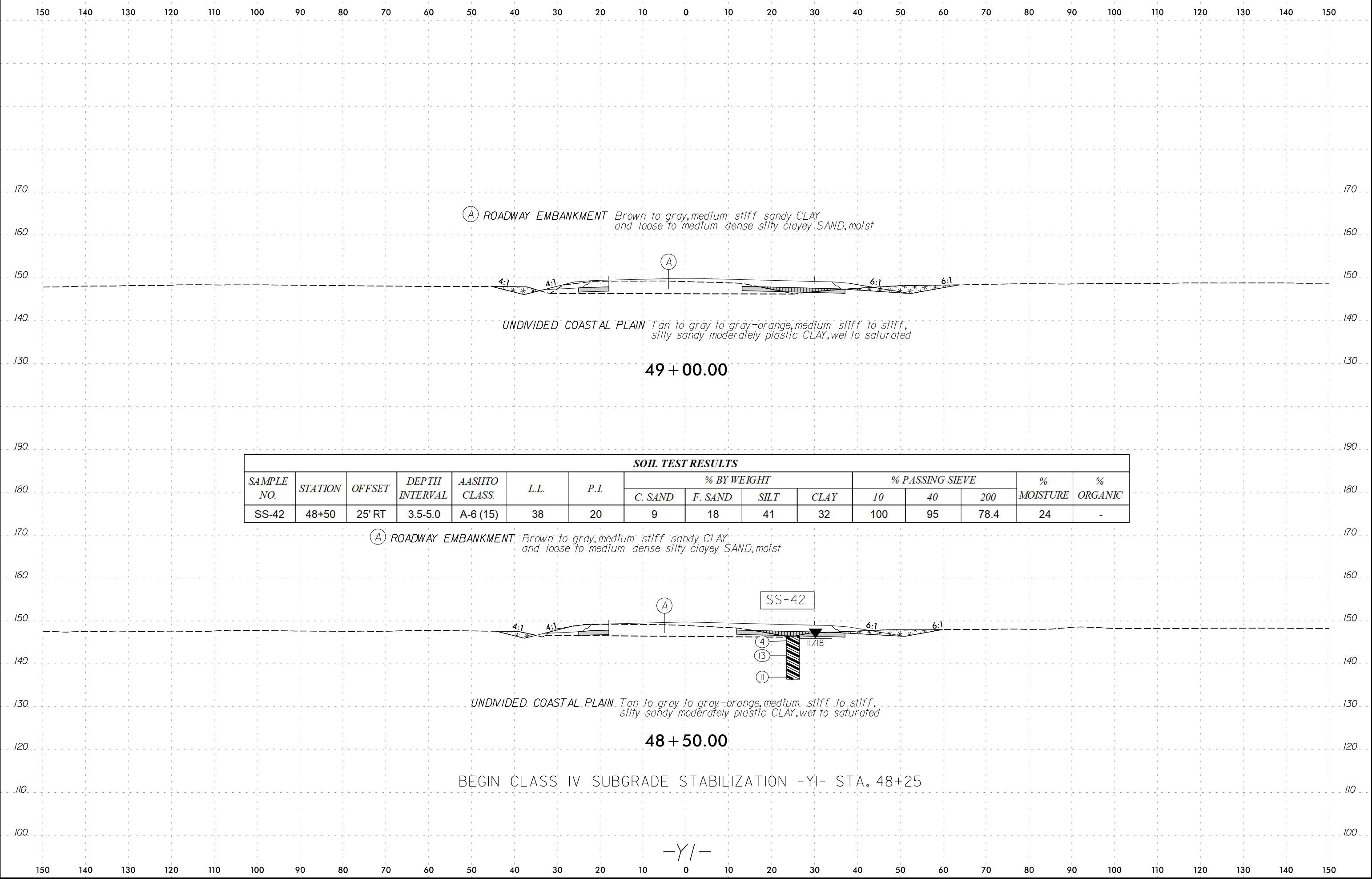

SOIL TEST RESULTS															
SAMPLE NO.	STATION	OFFSET	DEPTH INTERVAL	AASHTO CLASS.	L.L.	P.I.	% BY WEIGHT				% PASSING SIEVE			% MOISTURE	% ORGANIC
							C. SAND	F. SAND	SILT	CLAY	10	40	200		
SS-42	48+50	25' RT	3.5-5.0	A-6 (15)	38	20	9	18	41	32	100	95	78.4	24	-

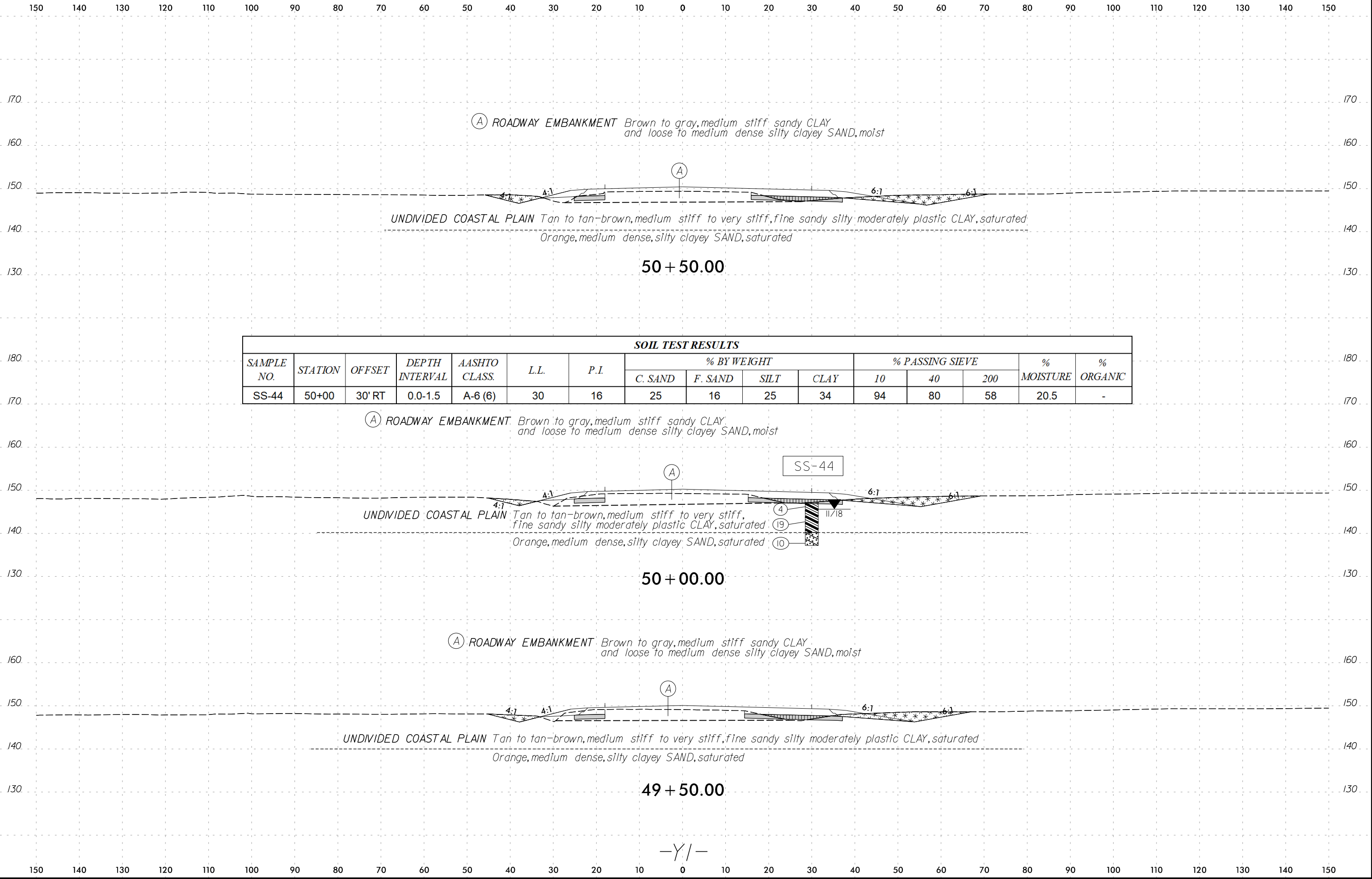

SOIL TEST RESULTS

SAMPLE NO.	STATION	OFFSET	DEPTH INTERVAL	AASHTO CLASS.	L.L.	P.I.	% BY WEIGHT				% PASSING SIEVE			% MOISTURE	% ORGANIC
							C. SAND	F. SAND	SILT	CLAY	10	40	200		
SS-44	50+00	30' RT	0.0-1.5	A-6 (6)	30	16	25	16	25	34	94	80	58	20.5	-

150 140 130 120 110 100 90 80 70 60 50 40 30 20 10 0 10 20 30 40 50 60 70 80 90 100 110 120 130 140 150

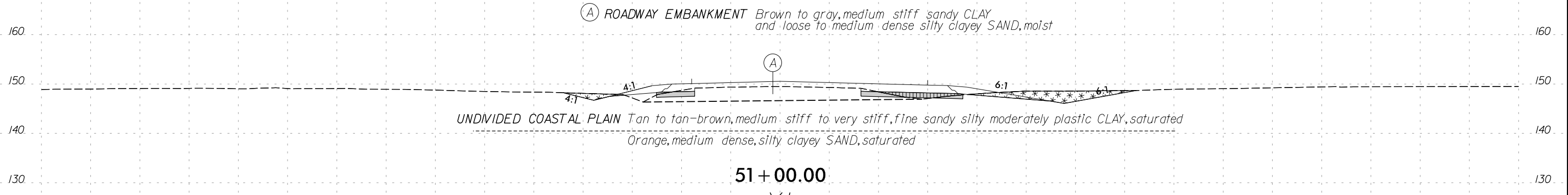
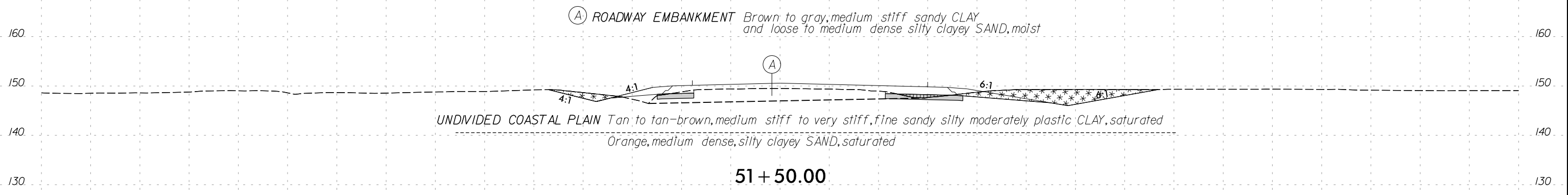
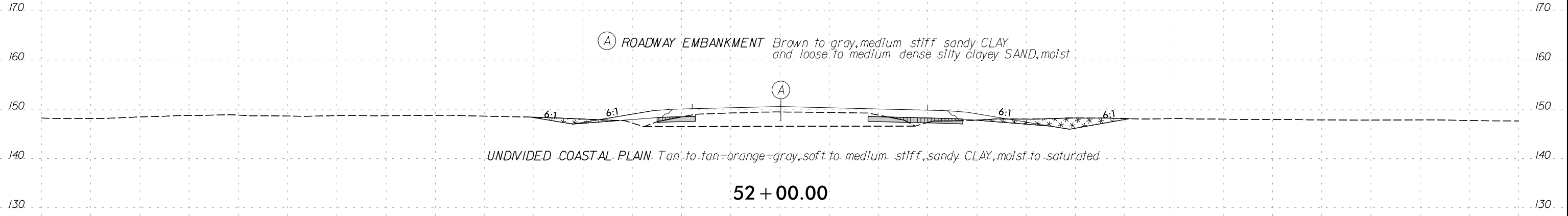

150 140 130 120 110 100 90 80 70 60 50 40 30 20 10 0 10 20 30 40 50 60 70 80 90 100 110 120 130 140 150

150 140 130 120 110 100 90 80 70 60 50 40 30 20 10 0 10 20 30 40 50 60 70 80 90 100 110 120 130 140 150

180 170 160 150 140 130 120 110 100 90 80 70 60 50 40 30 20 10 0 10 20 30 40 50 60 70 80 90 100 110 120 130 140 150

END CLASS IV SUBGRADE STABILIZATION -YI- STA.53+75

(A) ROADWAY EMBANKMENT *Brown to gray, medium stiff sandy CLAY and loose to medium dense silty clayey SAND, moist*

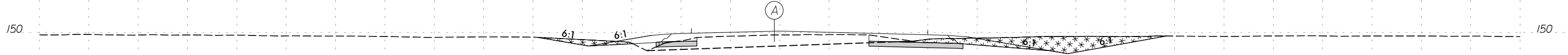

UNDIVIDED COASTAL PLAIN *Tan to tan-orange-gray, soft to medium stiff, sandy CLAY, moist to saturated*

53 + 50.00

BEGIN CLASS IV SUBGRADE STABILIZATION -YI- STA. 53+25

180 170 160 150 140 130 120 110 100 90 80 70 60 50 40 30 20 10 0 10 20 30 40 50 60 70 80 90 100 110 120 130 140 150

160 150 140 130 120 110 100 90 80 70 60 50 40 30 20 10 0 10 20 30 40 50 60 70 80 90 100 110 120 130 140 150

(A) ROADWAY EMBANKMENT *Brown to gray, medium stiff sandy CLAY and loose to medium dense silty clayey SAND, moist*

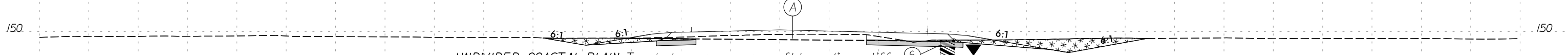

UNDIVIDED COASTAL PLAIN *Tan to tan-orange-gray, soft to medium stiff, sandy CLAY, moist to saturated*

53 + 00.00

170 160 150 140 130 120 110 100 90 80 70 60 50 40 30 20 10 0 10 20 30 40 50 60 70 80 90 100 110 120 130 140 150

END CLASS IV SUBGRADE STABILIZATION -YI- STA.52+75

(A) ROADWAY EMBANKMENT *Brown to gray, medium stiff sandy CLAY and loose to medium dense silty clayey SAND, moist*

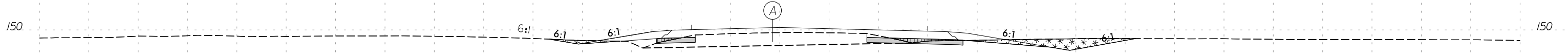

UNDIVIDED COASTAL PLAIN *Tan to tan-orange-gray, soft to medium stiff, sandy CLAY, moist to saturated*

52 + 50.00

-YI-

150 140 130 120 110 100 90 80 70 60 50 40 30 20 10 0 10 20 30 40 50 60 70 80 90 100 110 120 130 140 150

150 140 130 120 110 100 90 80 70 60 50 40 30 20 10 0 10 20 30 40 50 60 70 80 90 100 110 120 130 140 150

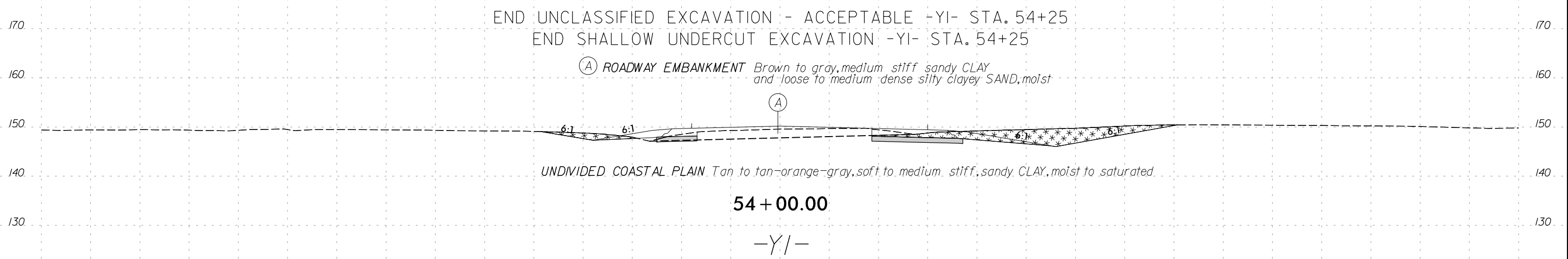
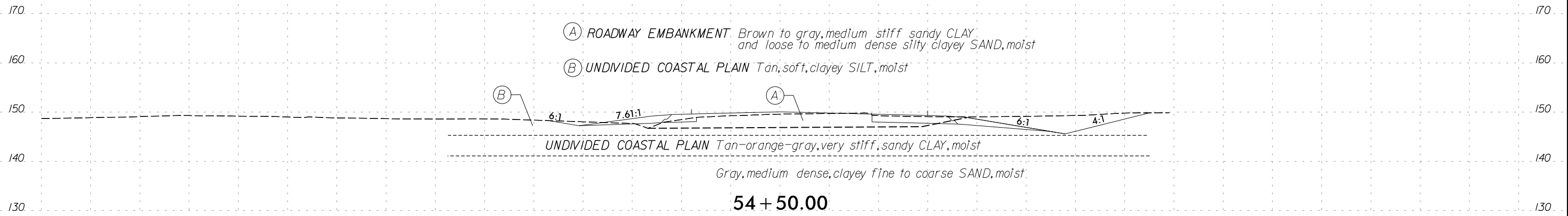

150 140 130 120 110 100 90 80 70 60 50 40 30 20 10 0 10 20 30 40 50 60 70 80 90 100 110 120 130 140 150

150 140 130 120 110 100 90 80 70 60 50 40 30 20 10 0 10 20 30 40 50 60 70 80 90 100 110 120 130 140 150

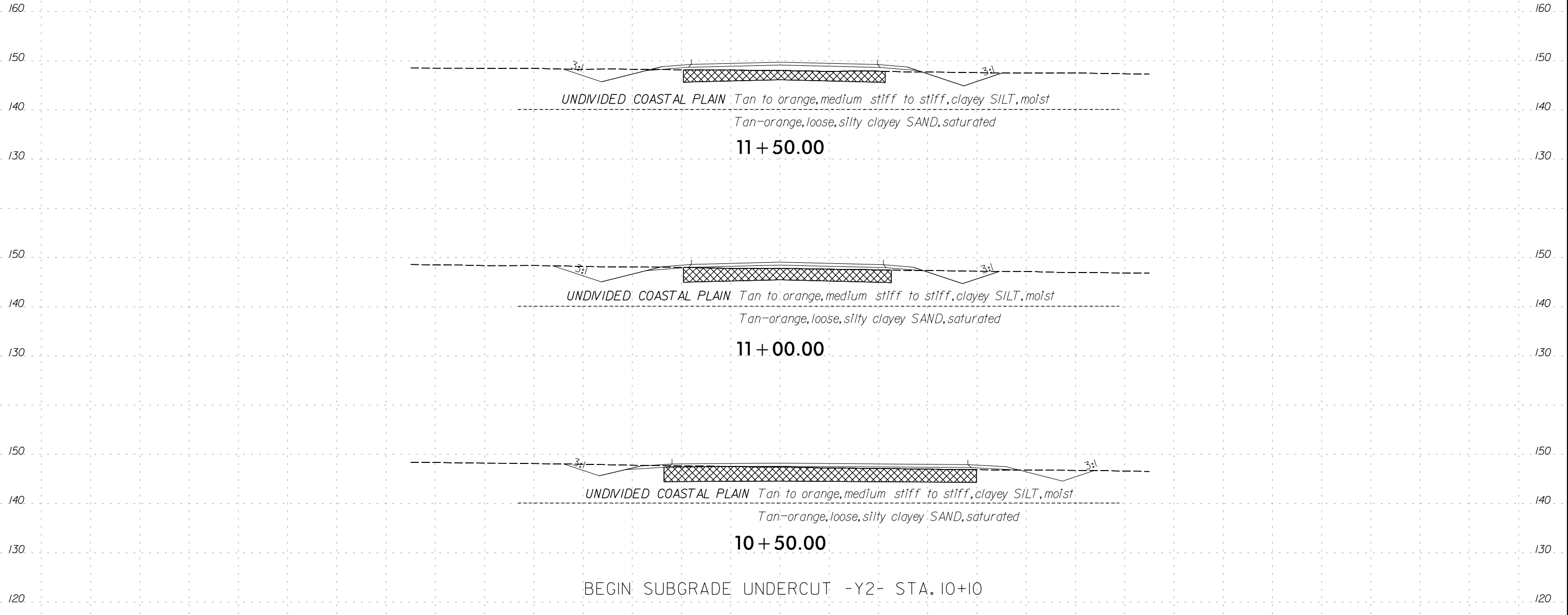

-Y2-

150 140 130 120 110 100 90 80 70 60 50 40 30 20 10 0 10 20 30 40 50 60 70 80 90 100 110 120 130 140 150

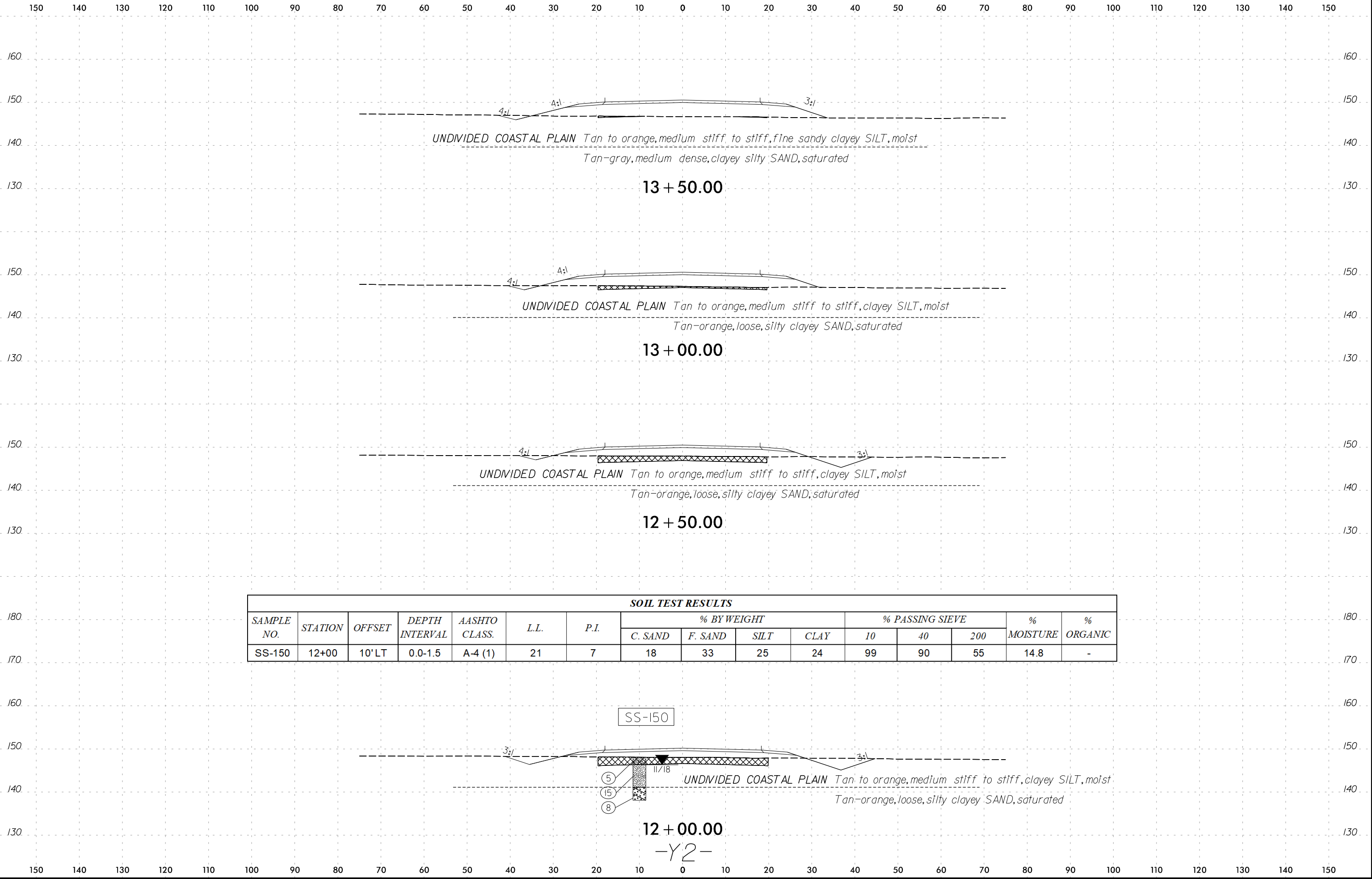

SOIL TEST RESULTS															
SAMPLE NO.	STATION	OFFSET	DEPTH INTERVAL	AASHTO CLASS.	L.L.	P.I.	% BY WEIGHT				% PASSING SIEVE			% MOISTURE	% ORGANIC
							C. SAND	F. SAND	SILT	CLAY	10	40	200		
SS-150	12+00	10' LT	0.0-1.5	A-4 (1)	21	7	18	33	25	24	99	90	55	14.8	-

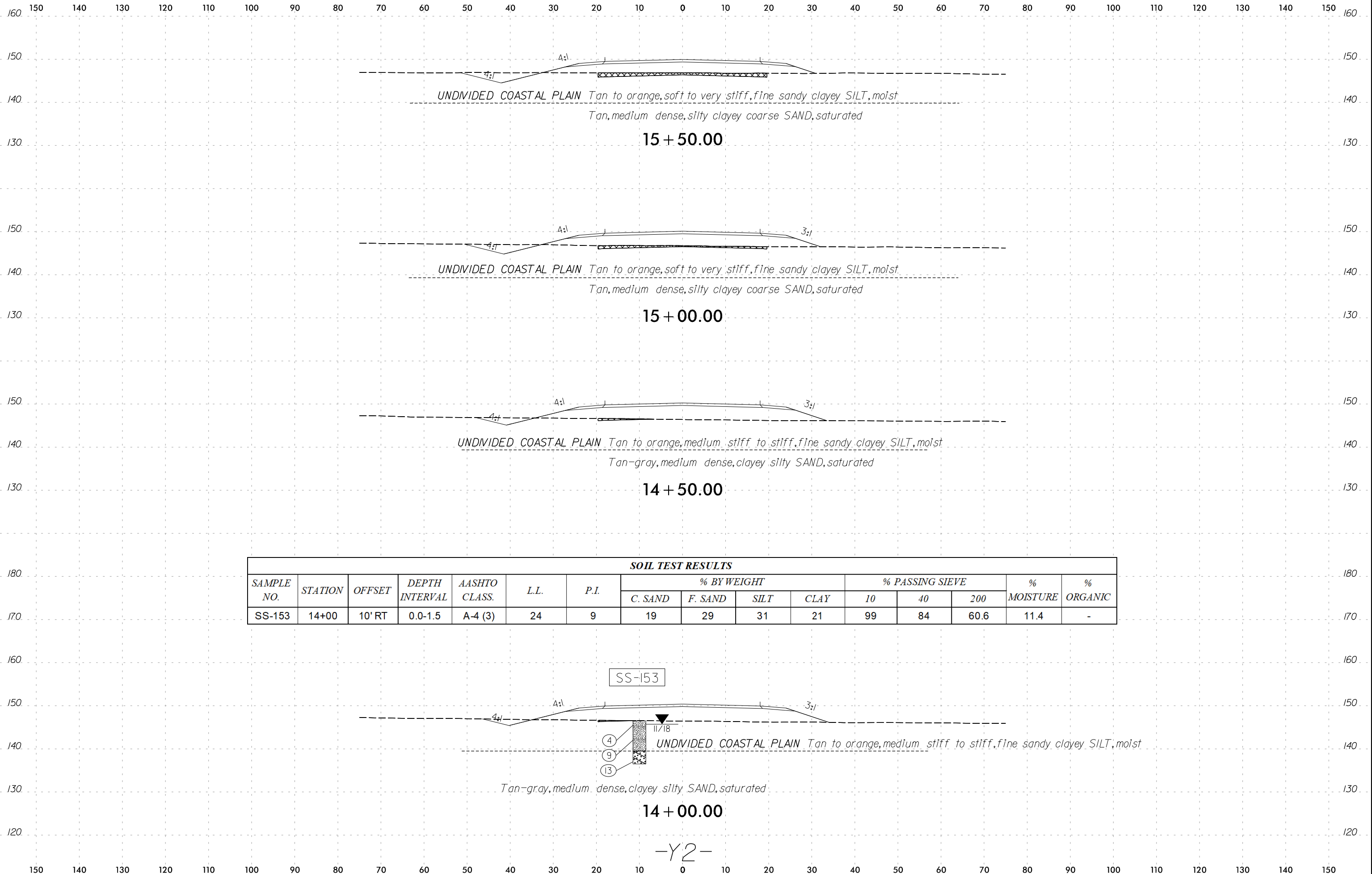

SOIL TEST RESULTS															
SAMPLE NO.	STATION	OFFSET	DEPTH INTERVAL	AASHTO CLASS.	L.L.	P.I.	% BY WEIGHT				% PASSING SIEVE			% MOISTURE	% ORGANIC
							C. SAND	F. SAND	SILT	CLAY	10	40	200		
SS-153	14+00	10' RT	0.0-1.5	A-4 (3)	24	9	19	29	31	21	99	84	60.6	11.4	-

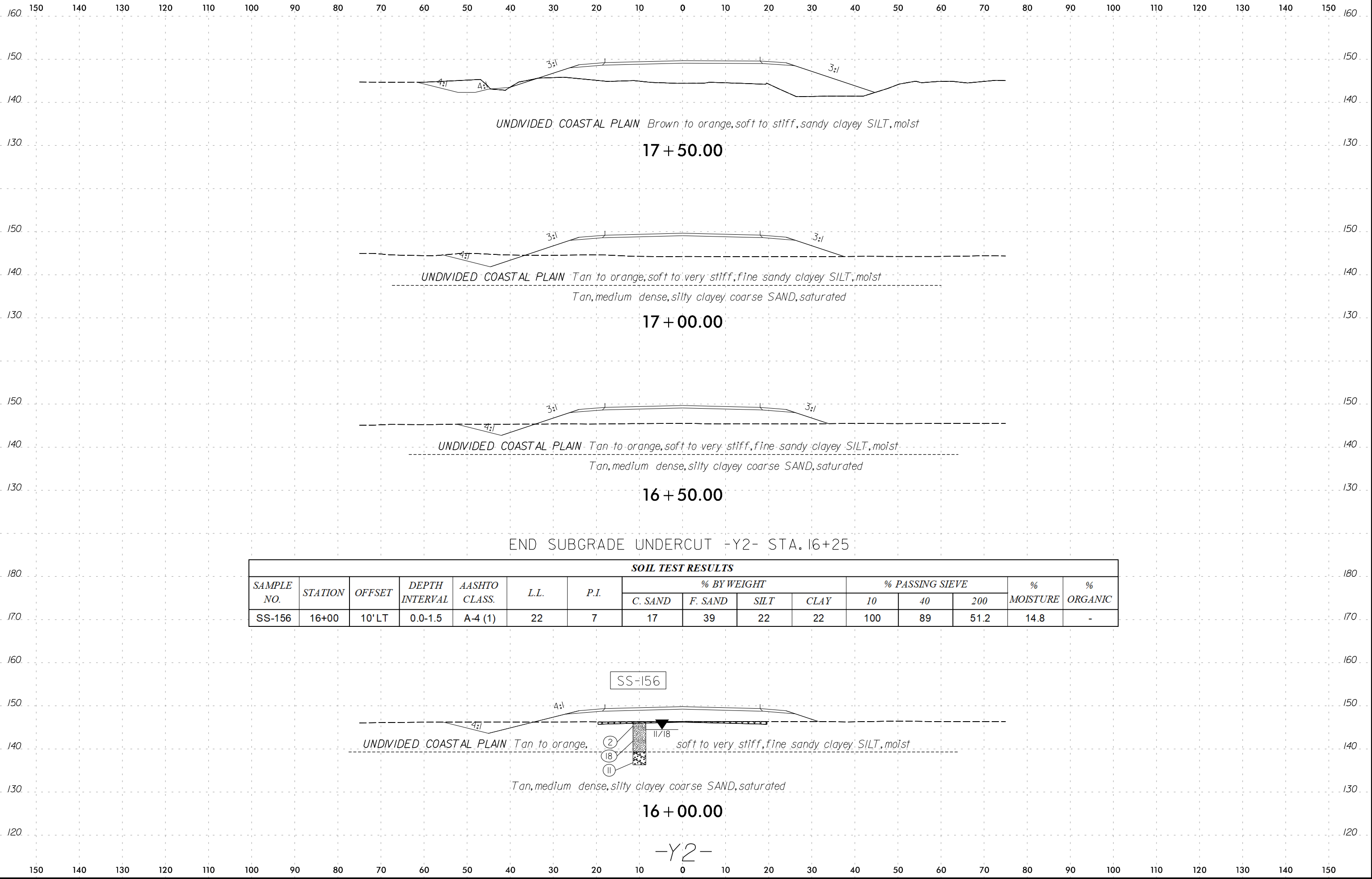

END SUBGRADE UNDERCUT -Y2- STA. 16+25

SOIL TEST RESULTS

SAMPLE NO.	STATION	OFFSET	DEPTH INTERVAL	AASHTO CLASS.	L.L.	P.I.	% BY WEIGHT				% PASSING SIEVE			% MOISTURE	% ORGANIC
							C. SAND	F. SAND	SILT	CLAY	10	40	200		
SS-156	16+00	10'LT	0.0-1.5	A-4 (1)	22	7	17	39	22	22	100	89	51.2	14.8	-

SS-156

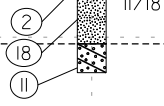

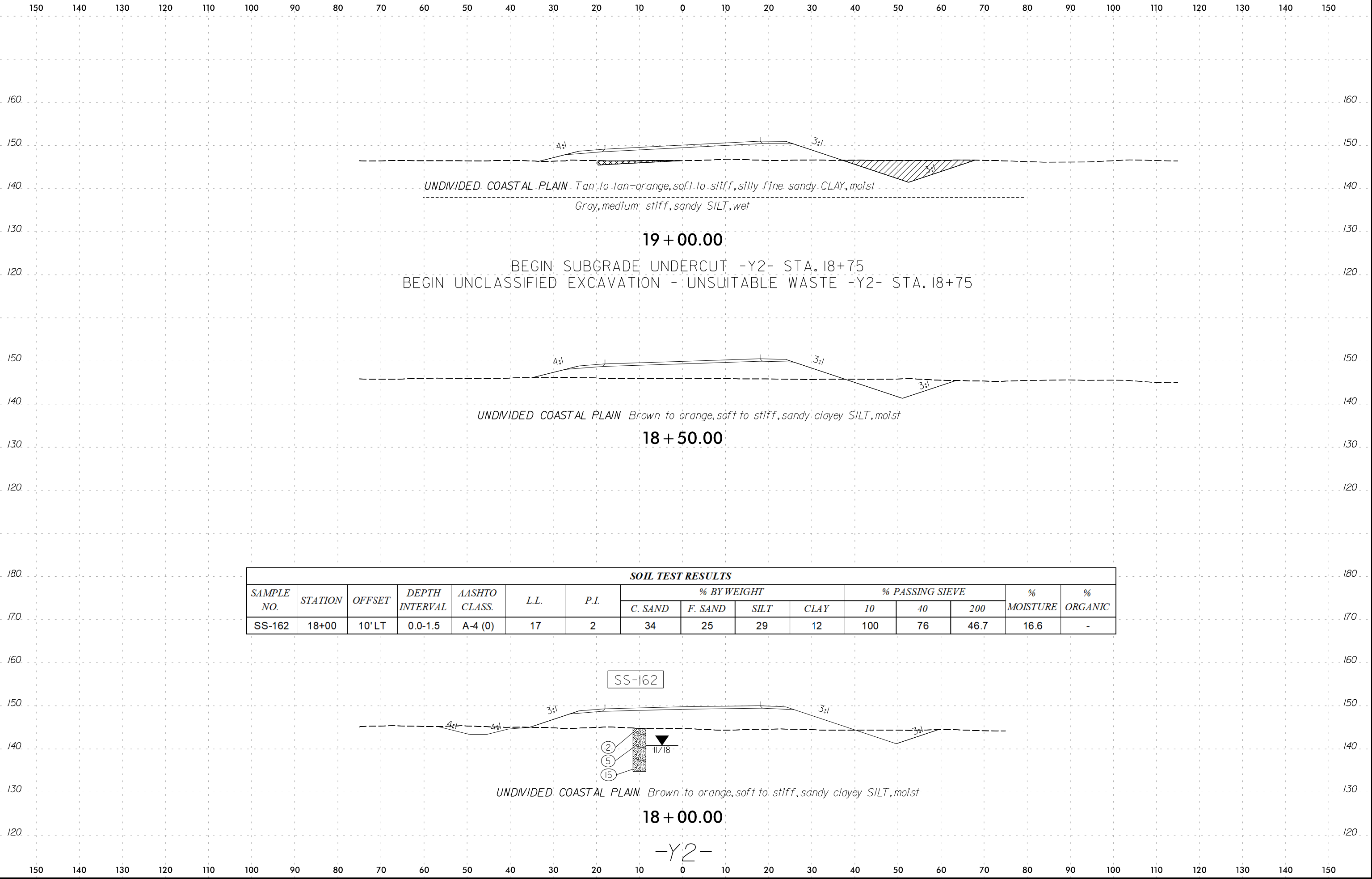

SOIL TEST RESULTS															
SAMPLE NO.	STATION	OFFSET	DEPTH INTERVAL	AASHTO CLASS.	L.L.	P.I.	% BY WEIGHT				% PASSING SIEVE			% MOISTURE	% ORGANIC
							C. SAND	F. SAND	SILT	CLAY	10	40	200		
SS-162	18+00	10' LT	0.0-1.5	A-4 (0)	17	2	34	25	29	12	100	76	46.7	16.6	-

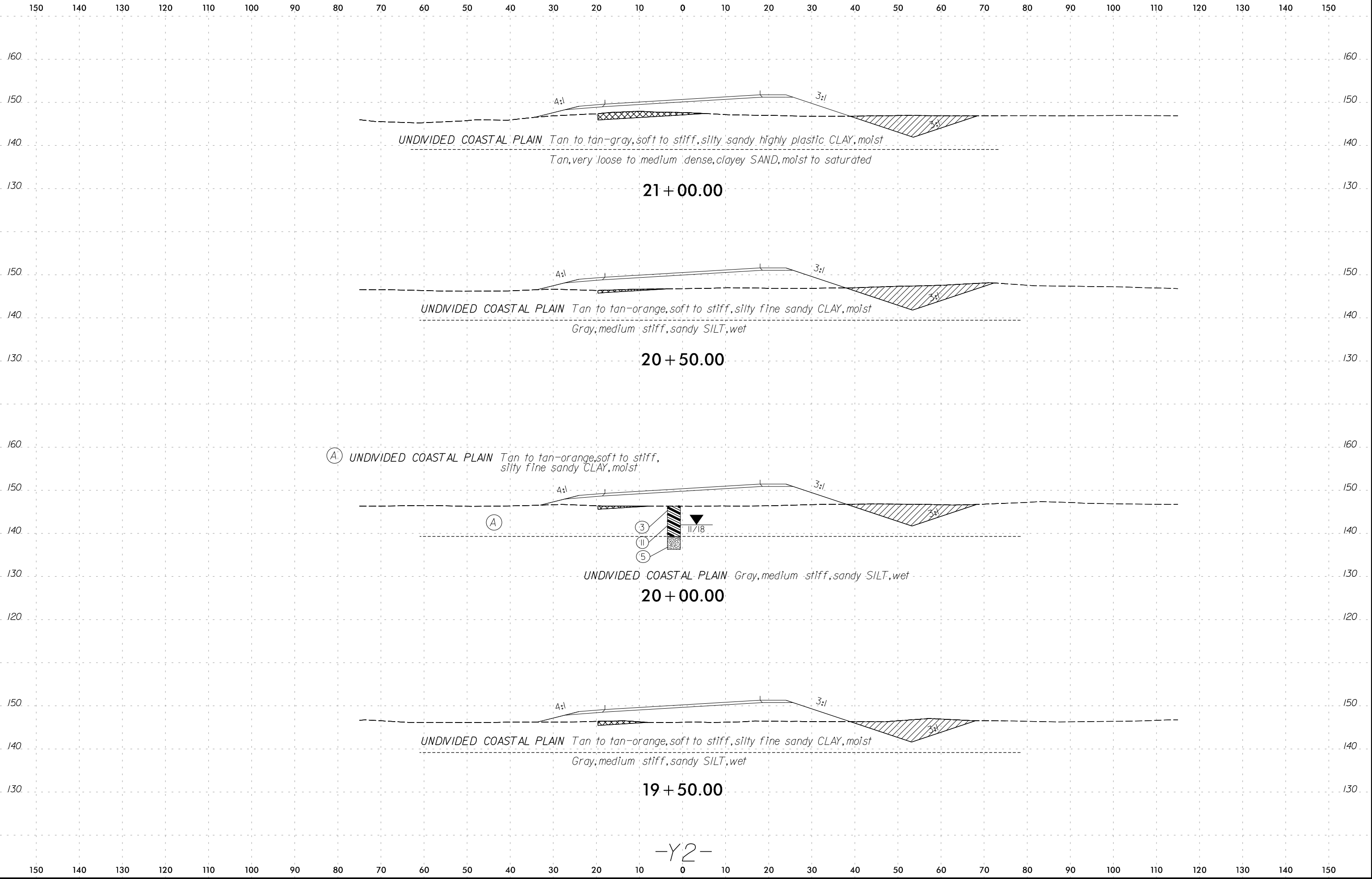

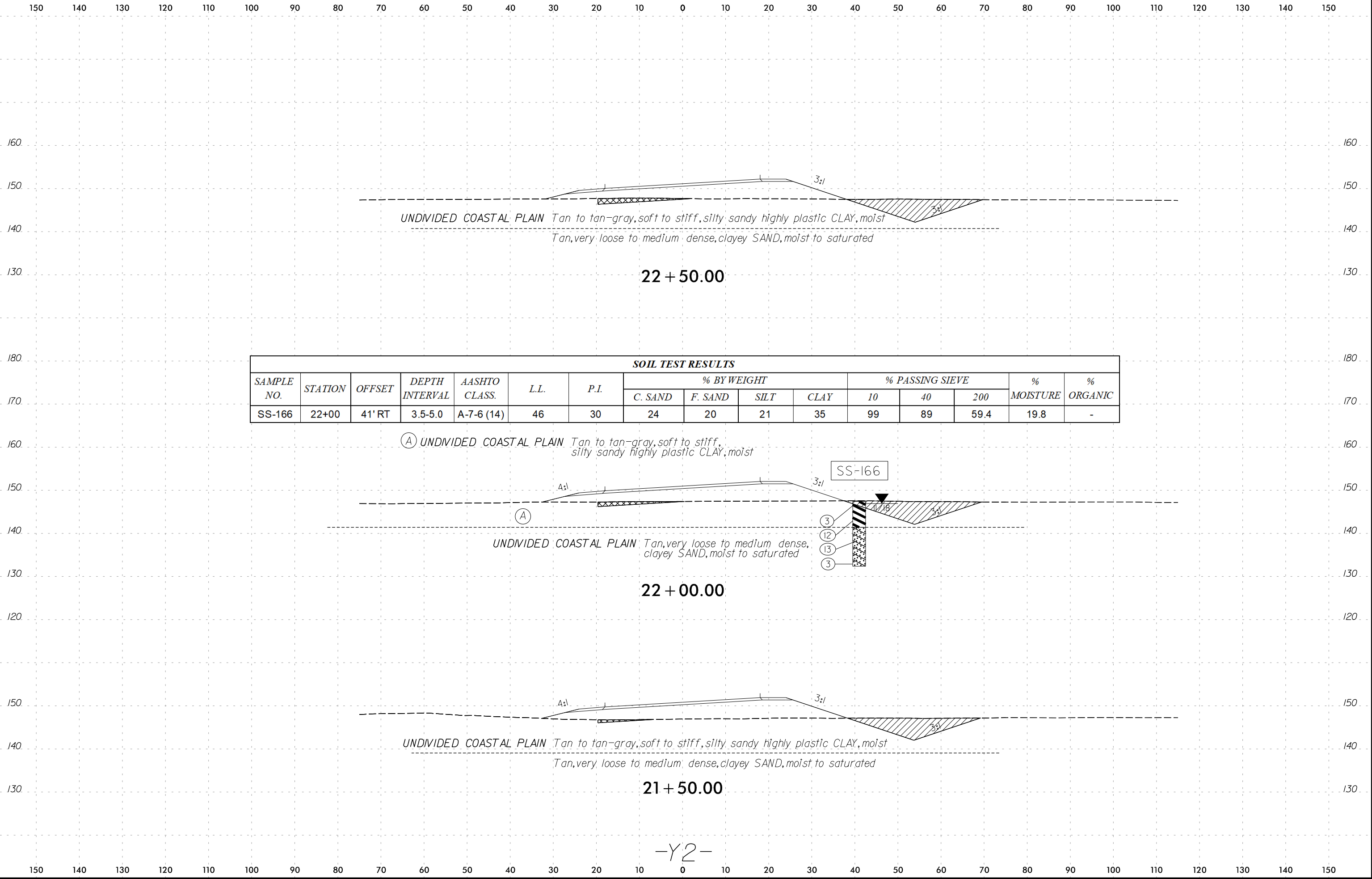

UNDIVIDED COASTAL PLAIN *Tan to tan-gray, soft to stiff, silty sandy highly plastic CLAY, moist*
Tan, very loose to medium dense, clayey SAND, moist to saturated

22 + 50.00

SOIL TEST RESULTS															
SAMPLE NO.	STATION	OFFSET	DEPTH INTERVAL	AASHTO CLASS.	L.L.	P.I.	% BY WEIGHT				% PASSING SIEVE			% MOISTURE	% ORGANIC
							C. SAND	F. SAND	SILT	CLAY	10	40	200		
SS-166	22+00	41' RT	3.5-5.0	A-7-6 (14)	46	30	24	20	21	35	99	89	59.4	19.8	-

(A) UNDIVIDED COASTAL PLAIN *Tan to tan-gray, soft to stiff, silty sandy highly plastic CLAY, moist*

UNDIVIDED COASTAL PLAIN *Tan, very loose to medium dense, clayey SAND, moist to saturated*

22 + 00.00

UNDIVIDED COASTAL PLAIN *Tan to tan-gray, soft to stiff, silty sandy highly plastic CLAY, moist*
Tan, very loose to medium dense, clayey SAND, moist to saturated

21 + 50.00

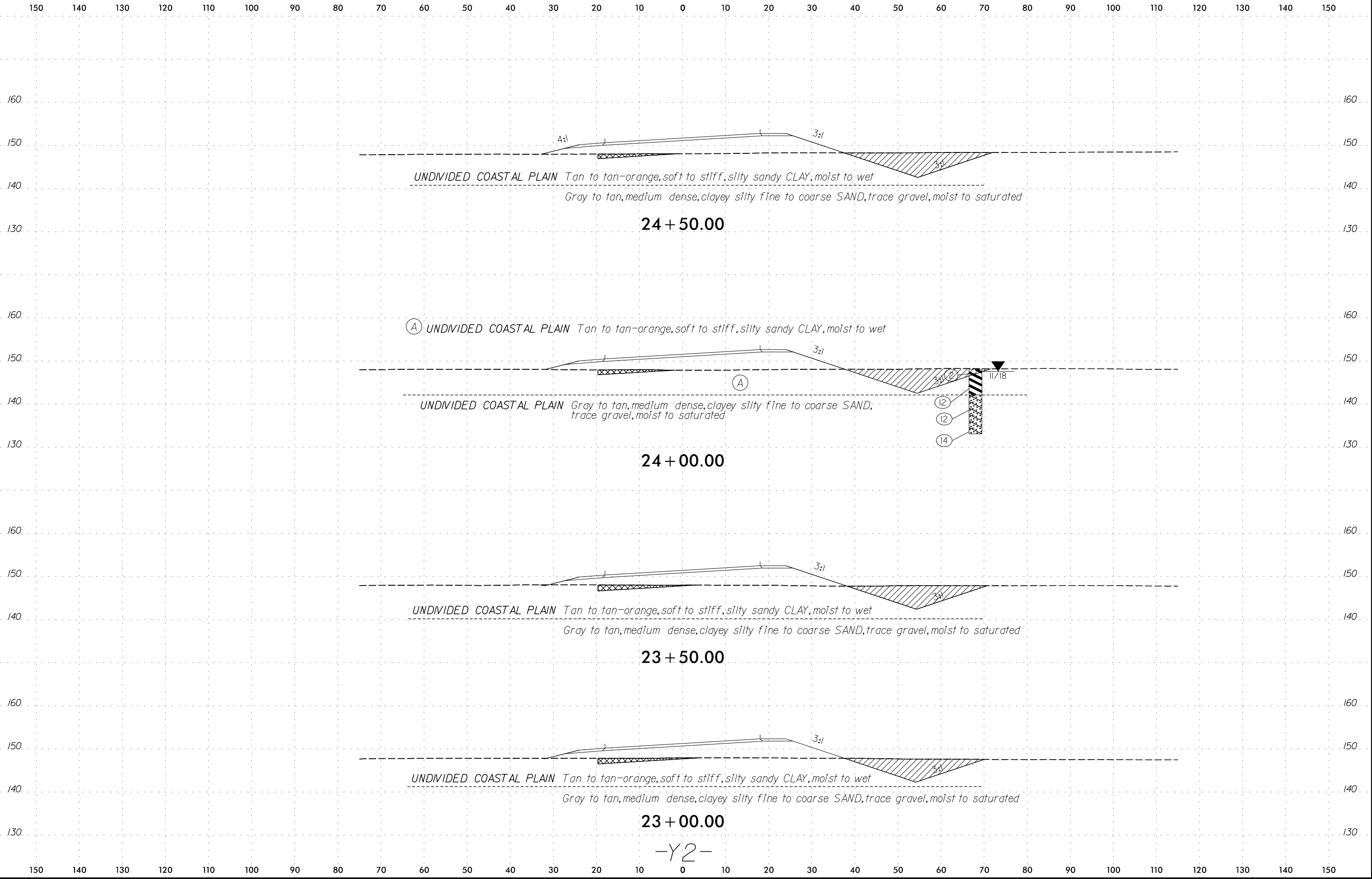

150 140 130 120 110 100 90 80 70 60 50 40 30 20 10 0 10 20 30 40 50 60 70 80 90 100 110 120 130 140 150

190 180 170 160 150 140 130

SOIL TEST RESULTS															
SAMPLE NO.	STATION	OFFSET	DEPTH INTERVAL	AASHTO CLASS.	L.L.	P.I.	% BY WEIGHT				% PASSING SIEVE			% MOISTURE	% ORGANIC
							C. SAND	F. SAND	SILT	CLAY	10	40	200		
SS-173	26+00	60' RT	0.0-1.5	A-6 (4)	27	13	25	20	27	28	99	87	58.3	23.3	-

160 150 140 130

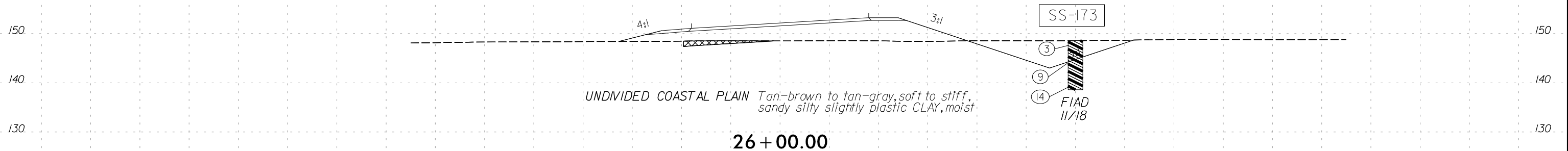

160 150 140 130

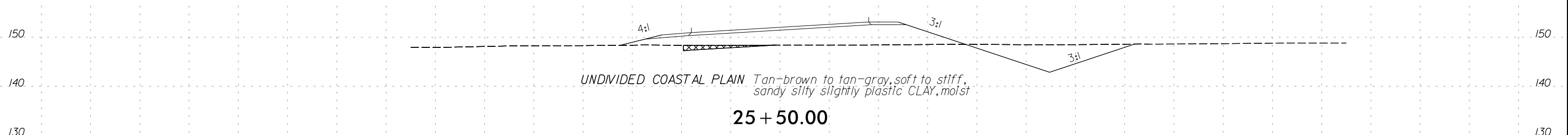

160 150 140 130

END UNCLASSIFIED EXCAVATION - UNSUITABLE WASTE -Y2- STA. 25+25

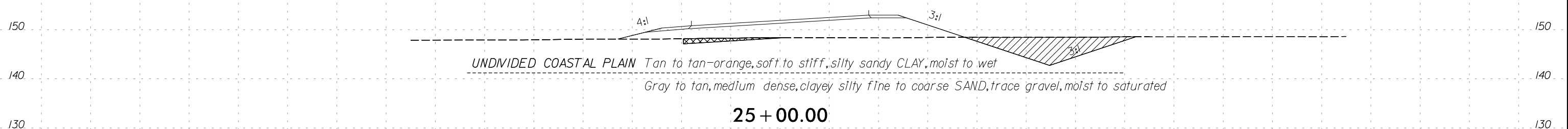

130 140 150 160 170 180 190

25 + 00.00
-Y2-

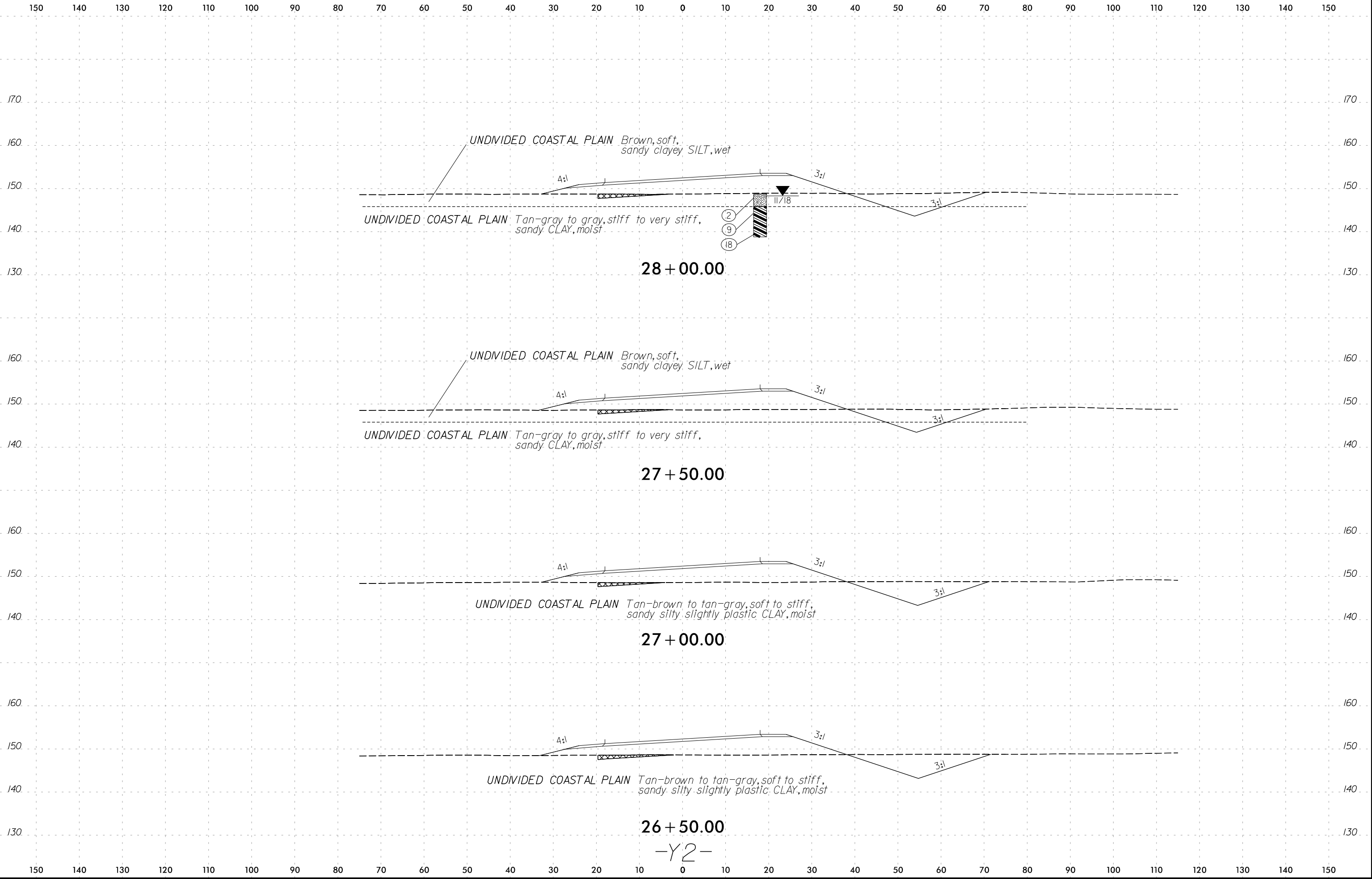

150 140 130 120 110 100 90 80 70 60 50 40 30 20 10 0 10 20 30 40 50 60 70 80 90 100 110 120 130 140 150

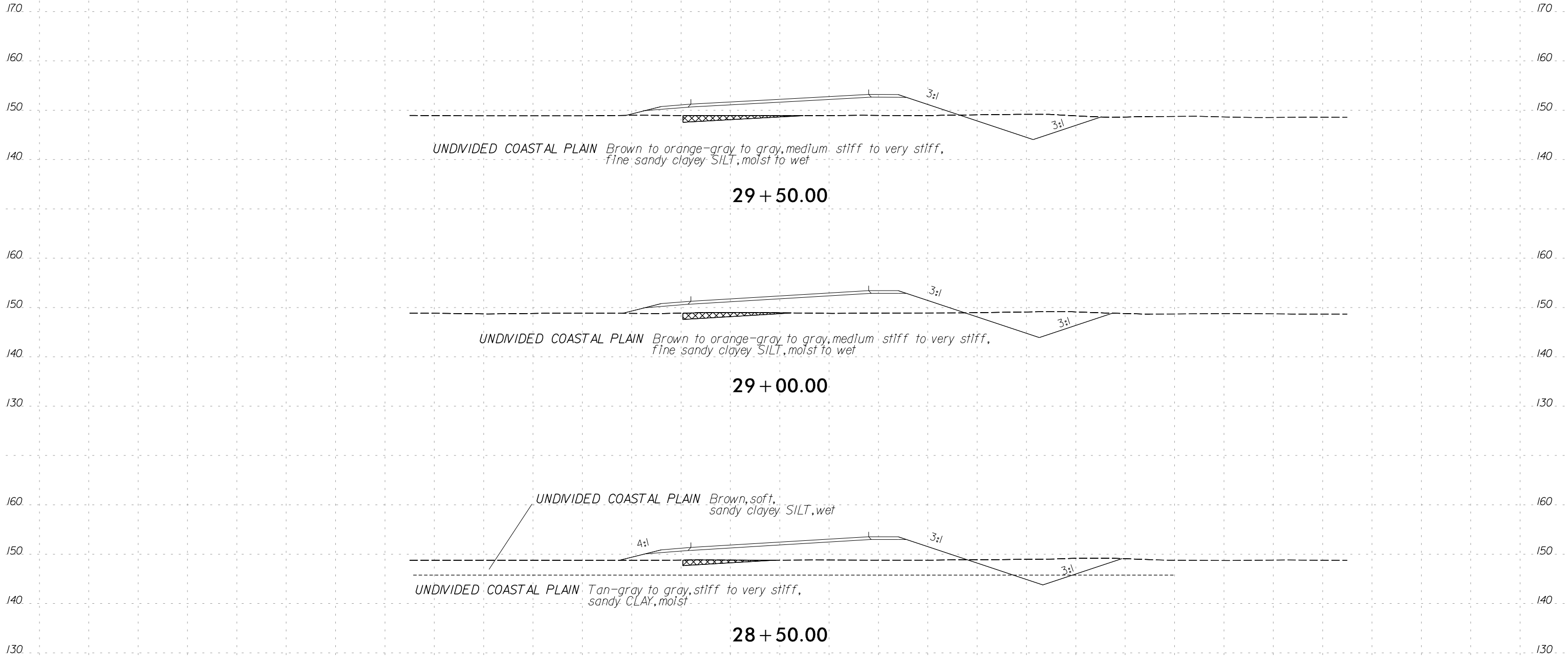

-Y2-

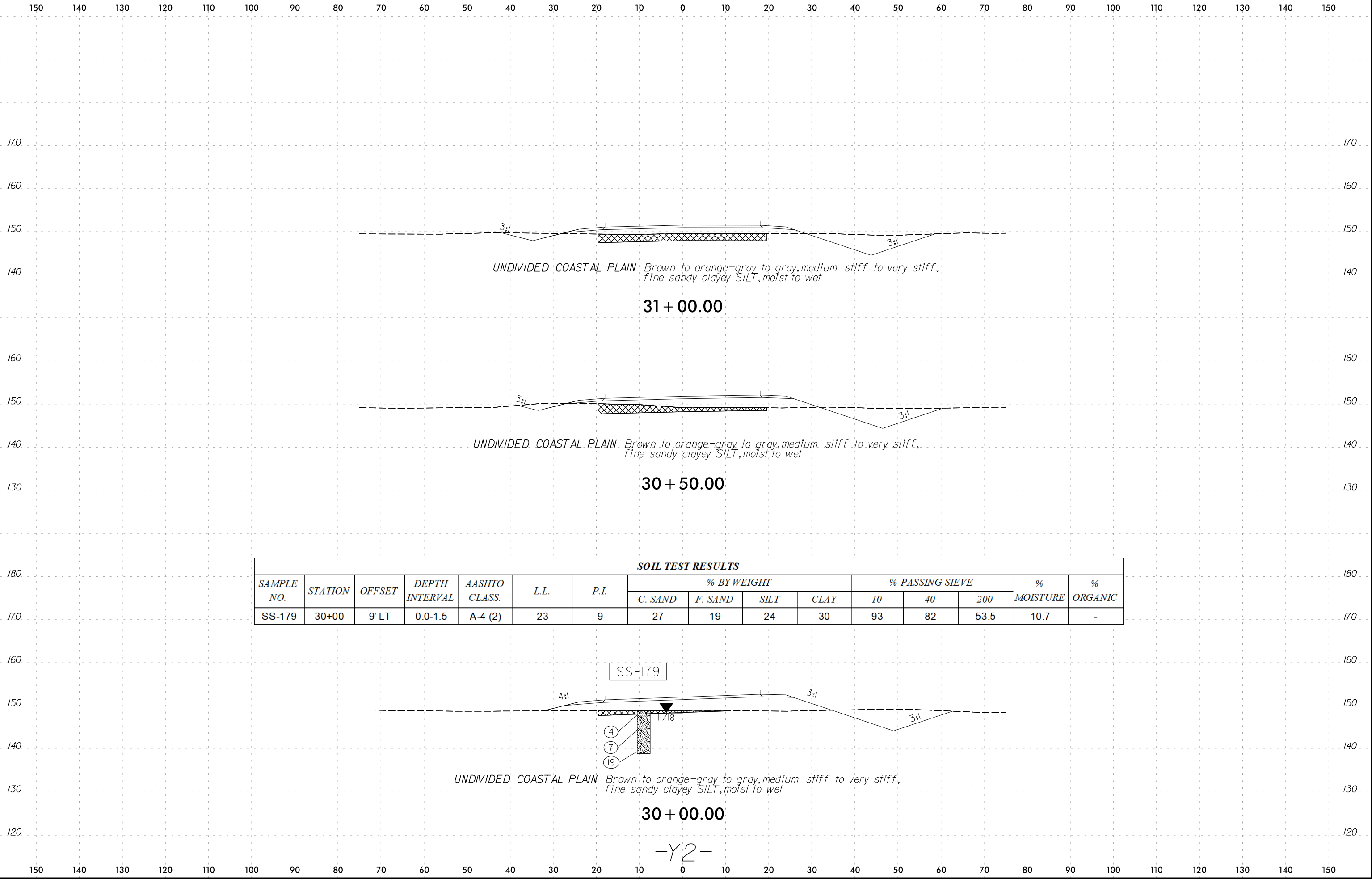

SOIL TEST RESULTS															
SAMPLE NO.	STATION	OFFSET	DEPTH INTERVAL	AASHTO CLASS.	L.L.	P.I.	% BY WEIGHT				% PASSING SIEVE			% MOISTURE	% ORGANIC
							C. SAND	F. SAND	SILT	CLAY	10	40	200		
SS-179	30+00	9' LT	0.0-1.5	A-4 (2)	23	9	27	19	24	30	93	82	53.5	10.7	-

150 140 130 120 110 100 90 80 70 60 50 40 30 20 10 0 10 20 30 40 50 60 70 80 90 100 110 120 130 140 150

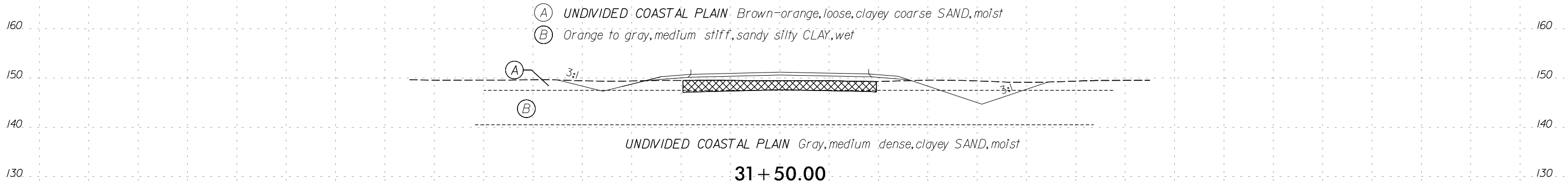
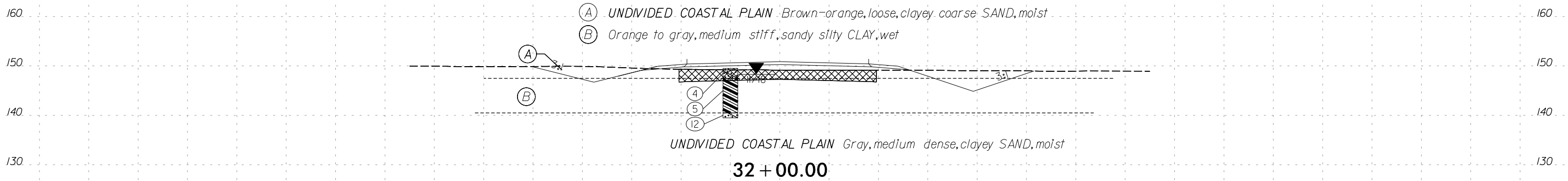
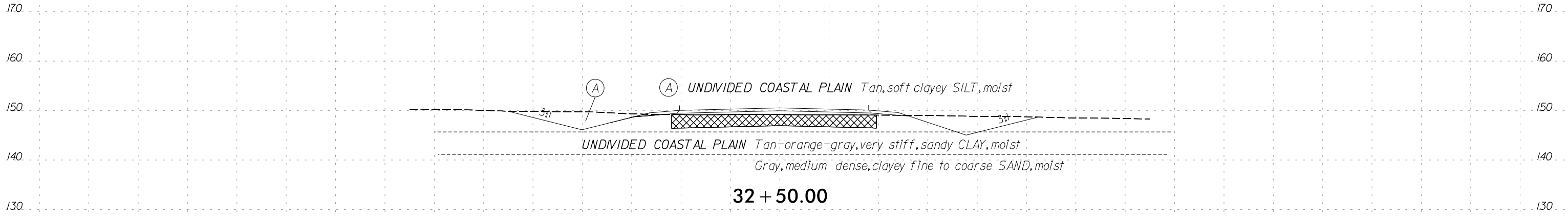

150 140 130 120 110 100 90 80 70 60 50 40 30 20 10 0 10 20 30 40 50 60 70 80 90 100 110 120 130 140 150

190

190

180

180

170

170

160

160

150

150

140

140

130

130

END SUBGRADE UNDERCUT -Y2- STA. 33+25

SOIL TEST RESULTS															
SAMPLE NO.	STATION	OFFSET	DEPTH INTERVAL	AASHTO CLASS.	L.L.	P.I.	% BYWEIGHT				% PASSING SIEVE			% MOISTURE	% ORGANIC
							C. SAND	F. SAND	SILT	CLAY	10	40	200		
SS-185	33+00	10' LT	0.0-1.5	A-4 (1)	20	8	29	23	24	24	92	79	48.9	16.2	-

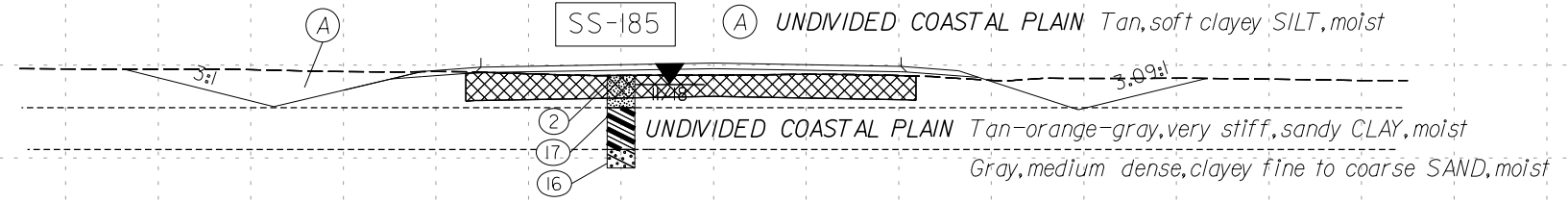

33 + 00.00

-Y2-

150 140 130 120 110 100 90 80 70 60 50 40 30 20 10 0 10 20 30 40 50 60 70 80 90 100 110 120 130 140 150

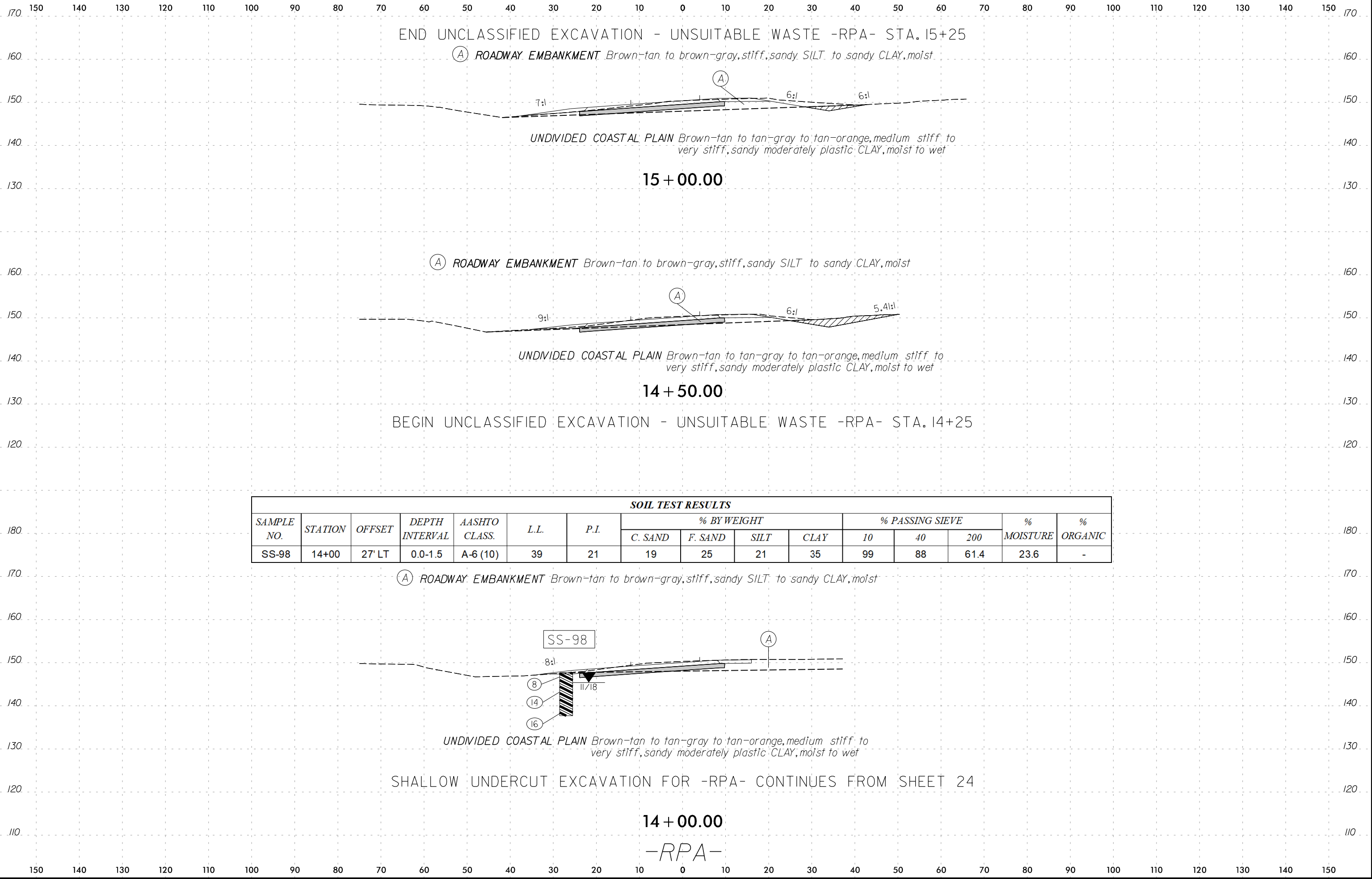

END UNCLASSIFIED EXCAVATION - UNSUITABLE WASTE -RPA- STA. 15+25

(A) ROADWAY EMBANKMENT *Brown-tan to brown-gray, stiff, sandy SILT to sandy CLAY, moist*

UNDIVIDED COASTAL PLAIN *Brown-tan to tan-gray to tan-orange, medium stiff to very stiff, sandy moderately plastic CLAY, moist to wet*

15 + 00.00

(A) ROADWAY EMBANKMENT *Brown-tan to brown-gray, stiff, sandy SILT to sandy CLAY, moist*

UNDIVIDED COASTAL PLAIN *Brown-tan to tan-gray to tan-orange, medium stiff to very stiff, sandy moderately plastic CLAY, moist to wet*

14 + 50.00

BEGIN UNCLASSIFIED EXCAVATION - UNSUITABLE WASTE -RPA- STA. 14+25

SOIL TEST RESULTS

SAMPLE NO.	STATION	OFFSET	DEPTH INTERVAL	AASHTO CLASS.	L.L.	P.I.	% BY WEIGHT				% PASSING SIEVE			% MOISTURE	% ORGANIC
							C. SAND	F. SAND	SILT	CLAY	10	40	200		
SS-98	14+00	27' LT	0.0-1.5	A-6 (10)	39	21	19	25	21	35	99	88	61.4	23.6	-

(A) ROADWAY EMBANKMENT *Brown-tan to brown-gray, stiff, sandy SILT to sandy CLAY, moist*

UNDIVIDED COASTAL PLAIN *Brown-tan to tan-gray to tan-orange, medium stiff to very stiff, sandy moderately plastic CLAY, moist to wet*

SHALLOW UNDERCUT EXCAVATION FOR -RPA- CONTINUES FROM SHEET 24

14 + 00.00

-RPA-

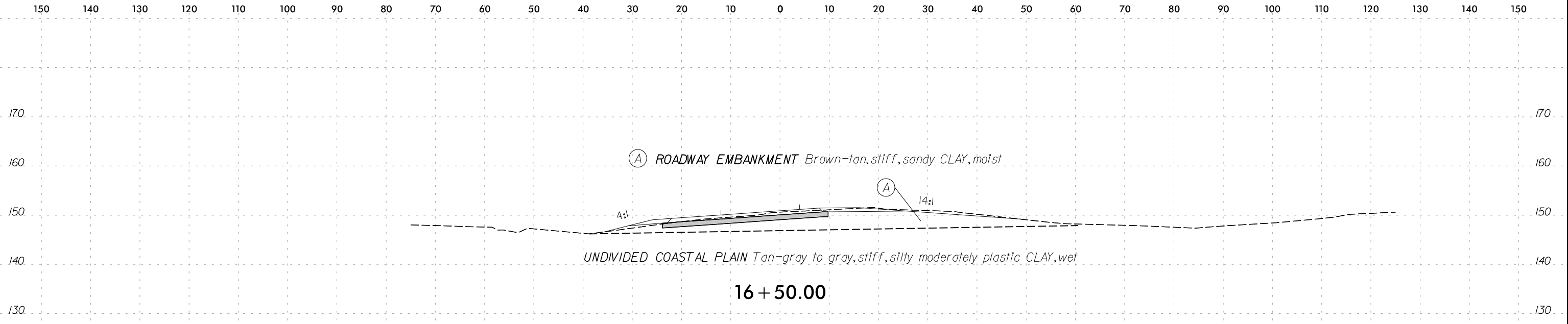

SOIL TEST RESULTS															
SAMPLE NO.	STATION	OFFSET	DEPTH INTERVAL	AASHTO CLASS.	L.L.	P.I.	% BY WEIGHT				% PASSING SIEVE			% MOISTURE	% ORGANIC
							C. SAND	F. SAND	SILT	CLAY	10	40	200		
SS-102	16+00	30' RT	3.5-5.0	A-6 (6)	37	20	31	23	16	30	95	78	48.9	22.6	-

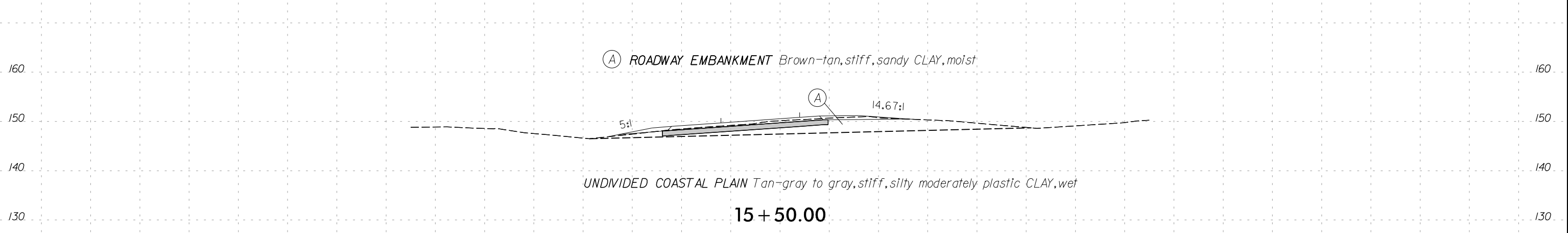
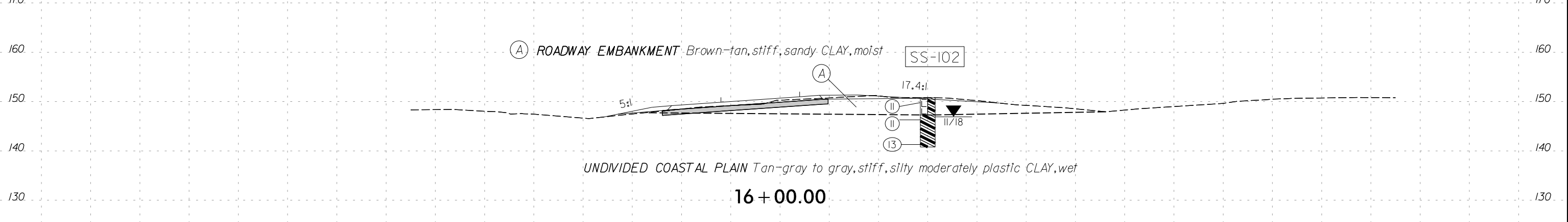

-RPA-

150 140 130 120 110 100 90 80 70 60 50 40 30 20 10 0 10 20 30 40 50 60 70 80 90 100 110 120 130 140 150

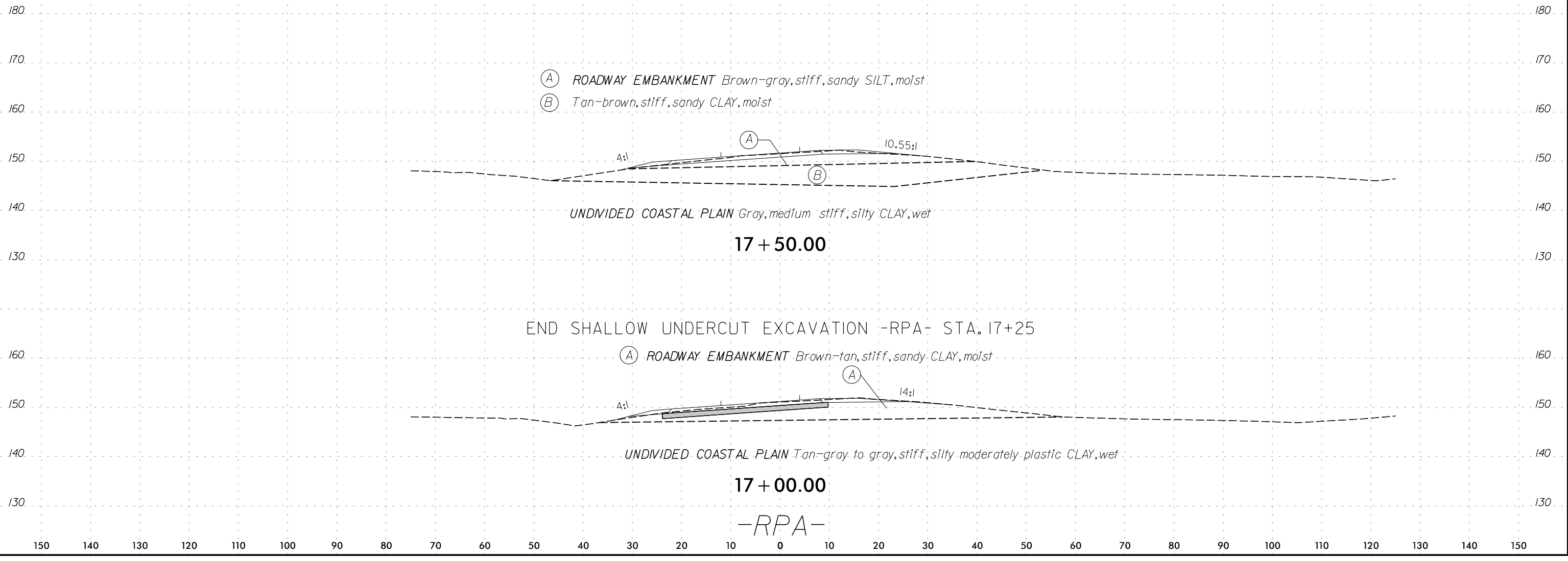

150 140 130 120 110 100 90 80 70 60 50 40 30 20 10 0 10 20 30 40 50 60 70 80 90 100 110 120 130 140 150

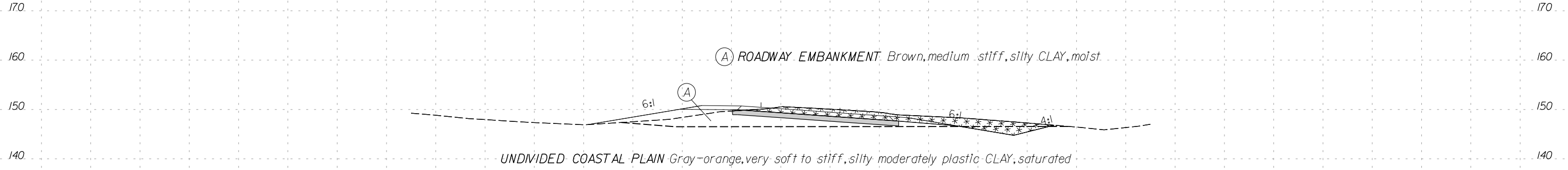

15 + 50.00

BEGIN UNCLASSIFIED EXCAVATION - ACCEPTABLE -RPB- STA. 15+25

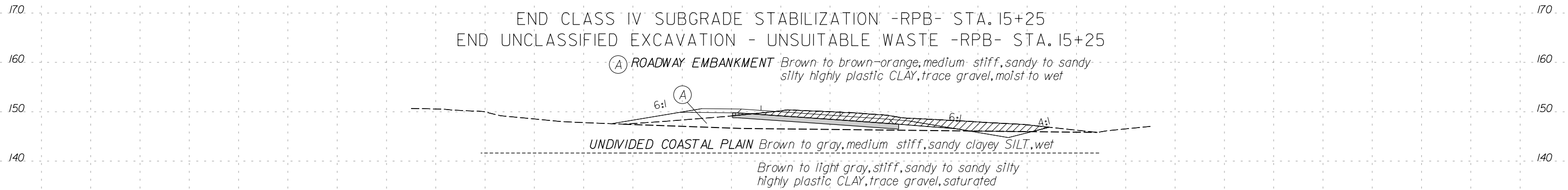

15 + 00.00

BEGIN CLASS IV SUBGRADE STABILIZATION -RPB- STA. 14+75

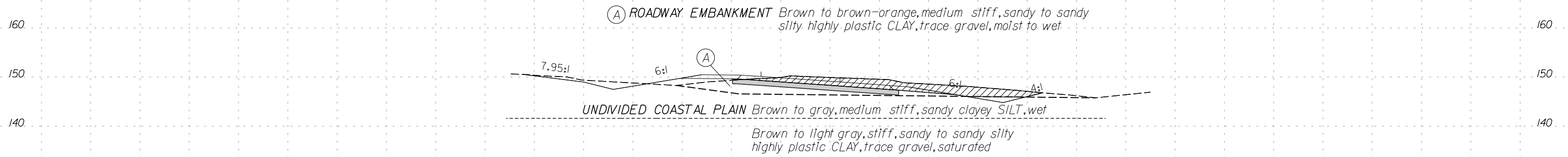

14 + 50.00

SHALLOW UNDERCUT EXCAVATION FOR -RPB- CONTINUES FROM SHEET 22
UNCLASSIFIED EXCAVATION - UNSUITABLE WASTE FOR -RPB- CONTINUES FROM SHEET 22

-RPB-

150 140 130 120 110 100 90 80 70 60 50 40 30 20 10 0 10 20 30 40 50 60 70 80 90 100 110 120 130 140 150

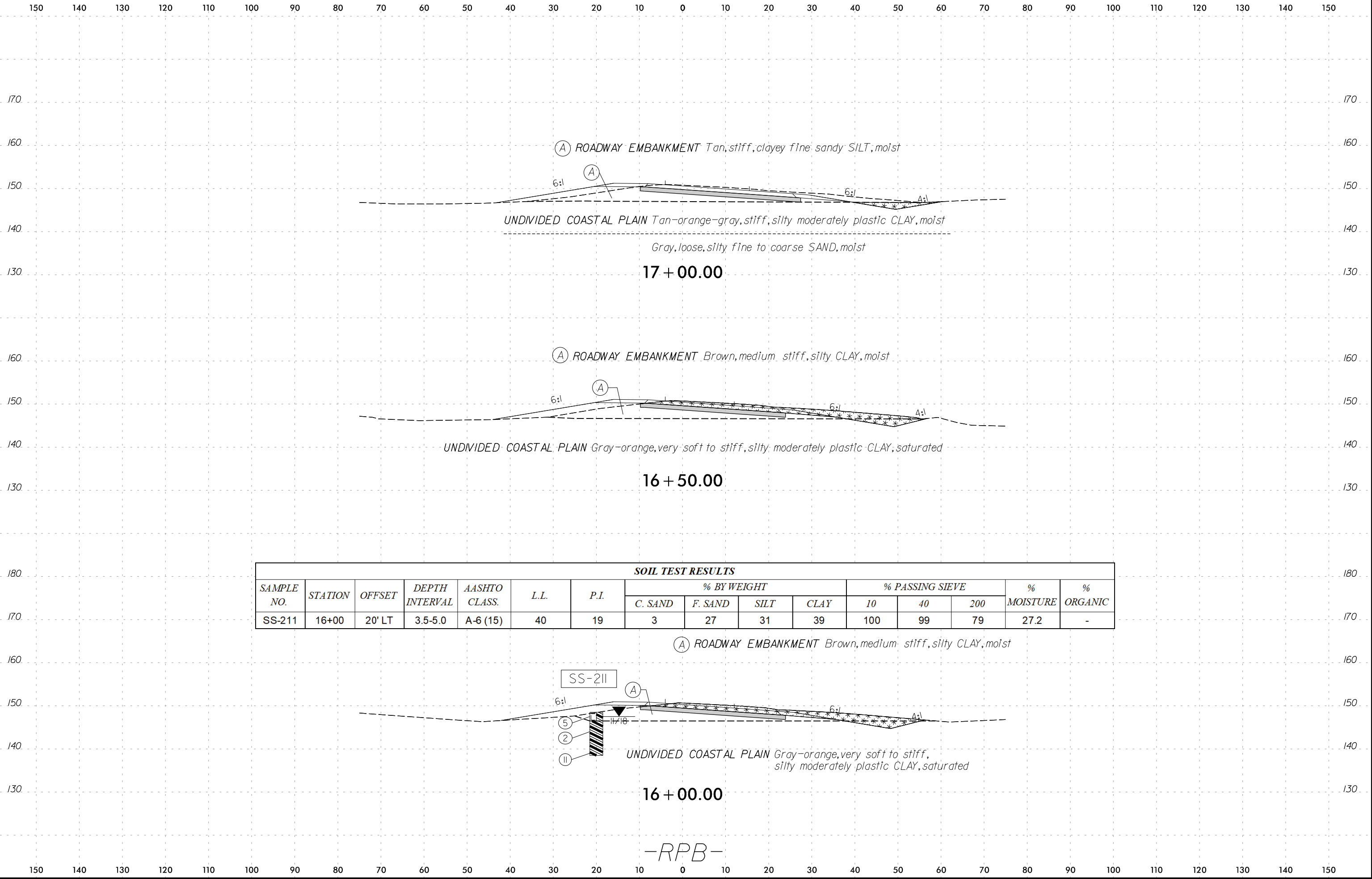

(A) ROADWAY EMBANKMENT Tan, stiff, clayey fine sandy SILT, moist

UNDIVIDED COASTAL PLAIN Tan-orange-gray, stiff, silty moderately plastic CLAY, moist
Gray, loose, silty fine to coarse SAND, moist

17 + 00.00

(A) ROADWAY EMBANKMENT Brown, medium stiff, silty CLAY, moist

UNDIVIDED COASTAL PLAIN Gray-orange, very soft to stiff, silty, moderately plastic CLAY, saturated

16 + 50.00

SOIL TEST RESULTS

SAMPLE NO.	STATION	OFFSET	DEPTH INTERVAL	AASHTO CLASS.	L.L.	P.I.	% BY WEIGHT				% PASSING SIEVE			% MOISTURE	% ORGANIC
							C. SAND	F. SAND	SILT	CLAY	10	40	200		
SS-211	16+00	20' LT	3.5-5.0	A-6 (15)	40	19	3	27	31	39	100	99	79	27.2	-

(A) ROADWAY EMBANKMENT Brown, medium stiff, silty CLAY, moist

UNDIVIDED COASTAL PLAIN Gray-orange, very soft to stiff, silty moderately plastic CLAY, saturated

16 + 00.00

-RPB-

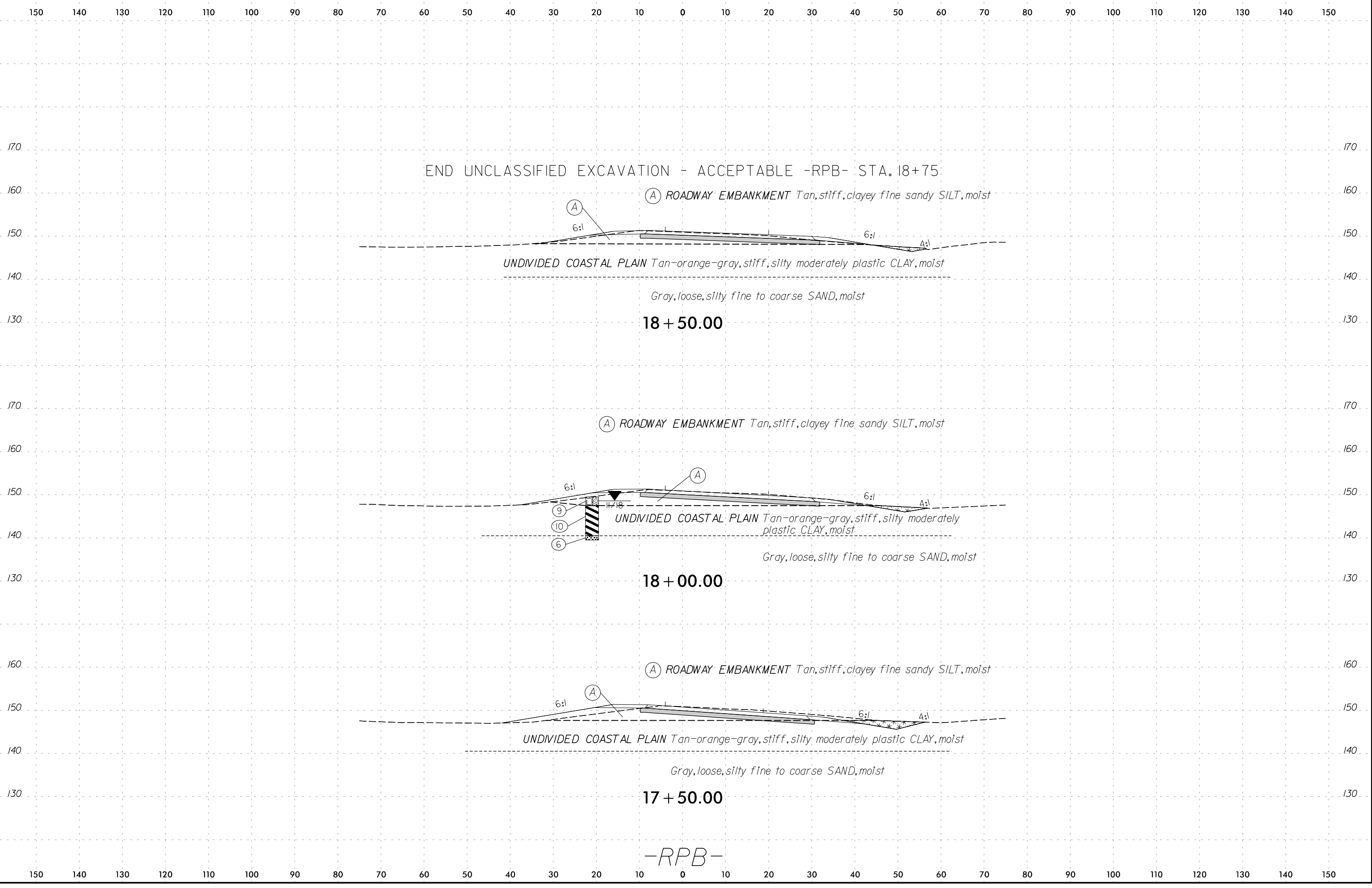

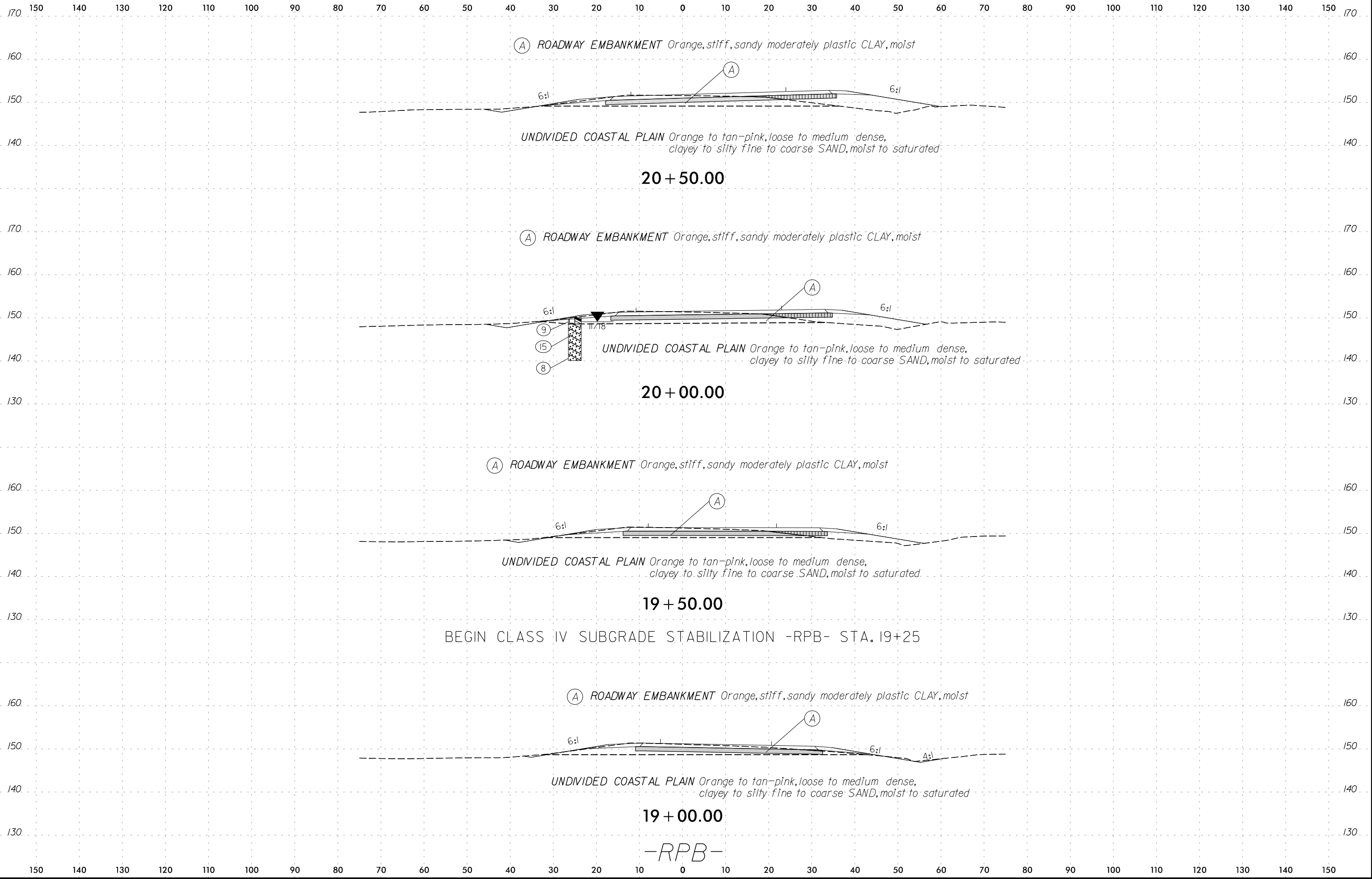

SOIL TEST RESULTS															
SAMPLE NO.	STATION	OFFSET	DEPTH INTERVAL	AASHTO CLASS.	L.L.	P.I.	% BY WEIGHT				% PASSING SIEVE			% MOISTURE	% ORGANIC
							C. SAND	F. SAND	SILT	CLAY	10	40	200		
SS-219	22+00	8' LT	0.0-1.5	A-6 (6)	35	16	24	21	23	32	93	76	56.4	15.3	-

(A) ROADWAY EMBANKMENT *Brown, medium stiff, sandy silty moderately plastic CLAY, wet*

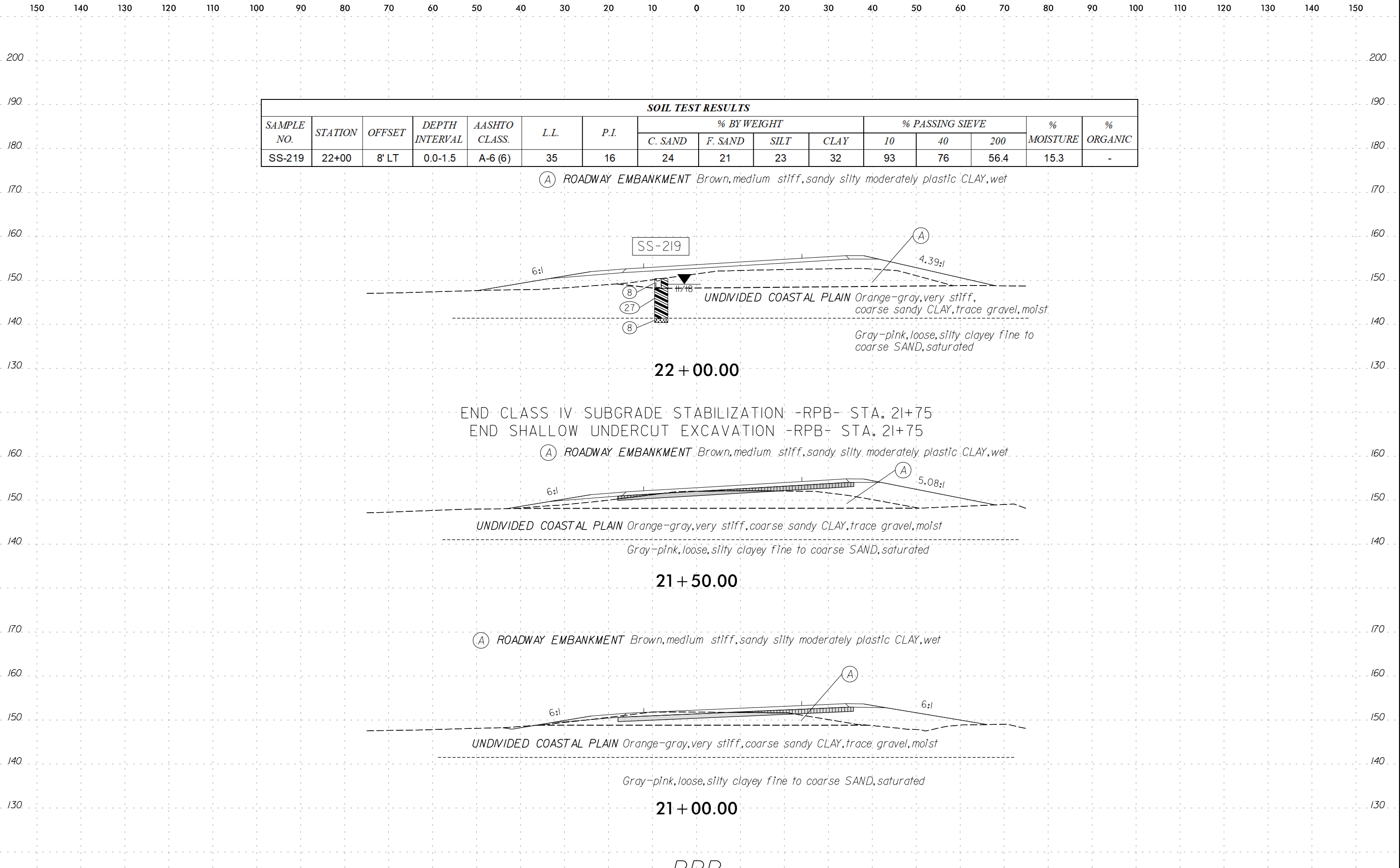

22 + 00.00

END CLASS IV SUBGRADE STABILIZATION -RPB- STA. 21+75
 END SHALLOW UNDERCUT EXCAVATION -RPB- STA. 21+75

21 + 50.00

21 + 00.00

-RPB-

150 140 130 120 110 100 90 80 70 60 50 40 30 20 10 0 10 20 30 40 50 60 70 80 90 100 110 120 130 140 150

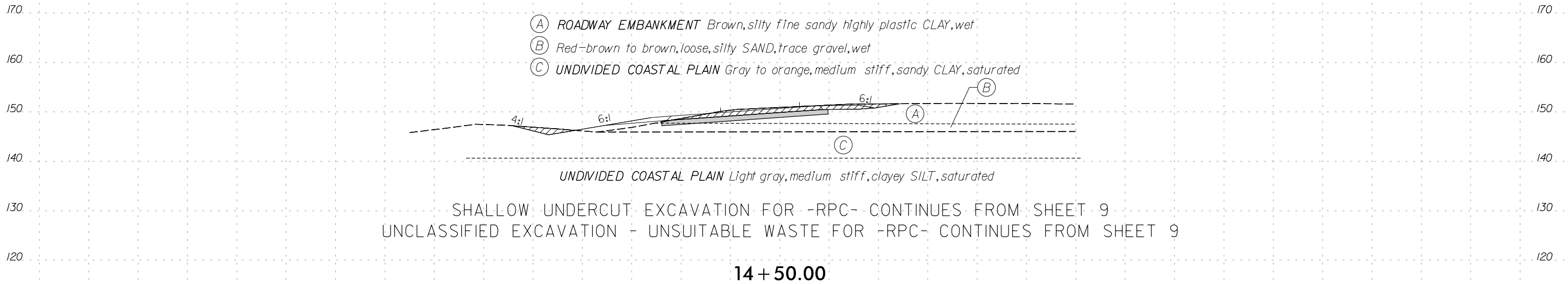
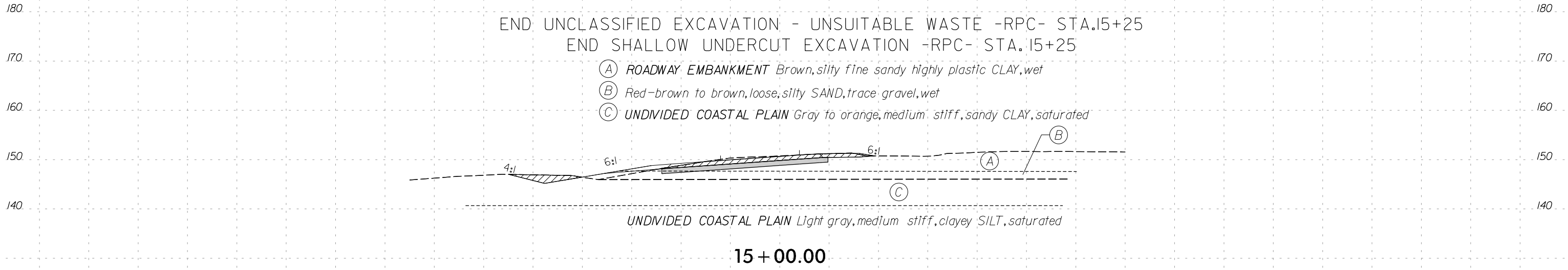
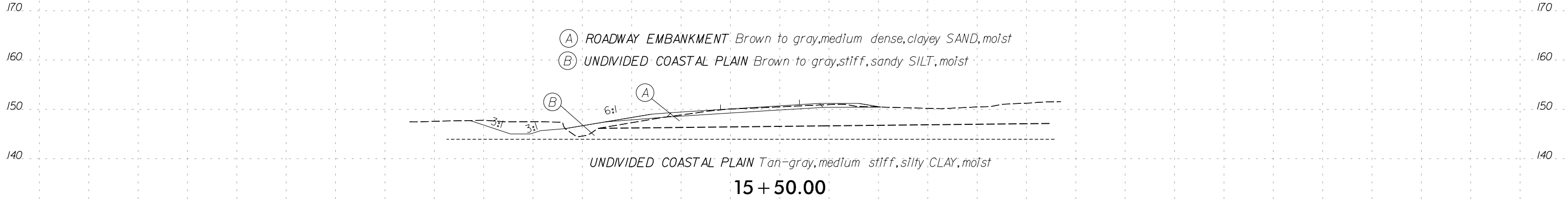

-RPC-

150 140 130 120 110 100 90 80 70 60 50 40 30 20 10 0 10 20 30 40 50 60 70 80 90 100 110 120 130 140 150

150 140 130 120 110 100 90 80 70 60 50 40 30 20 10 0 10 20 30 40 50 60 70 80 90 100 110 120 130 140 150

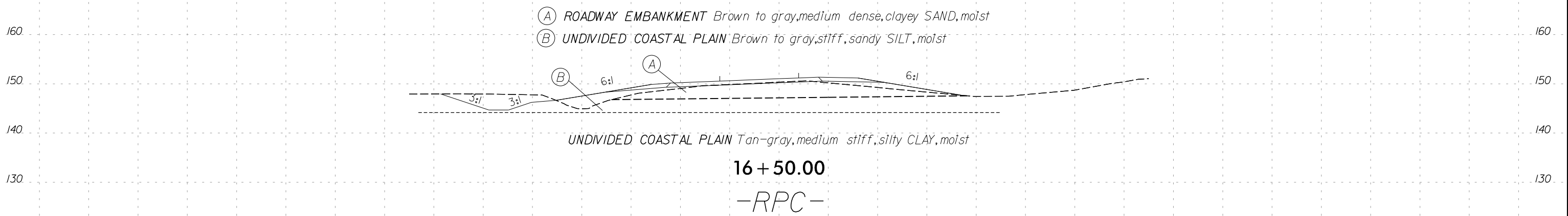
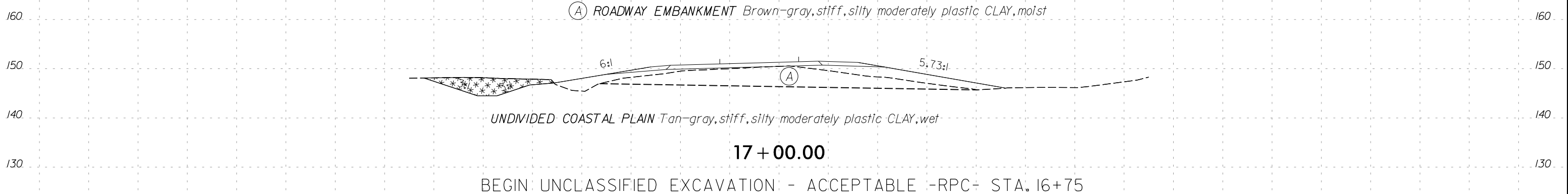
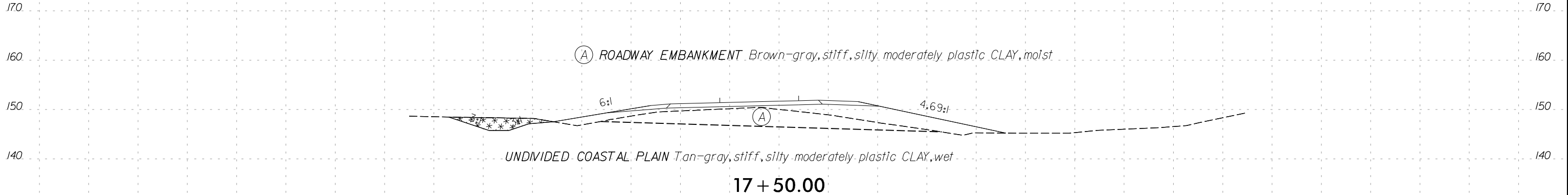

150 140 130 120 110 100 90 80 70 60 50 40 30 20 10 0 10 20 30 40 50 60 70 80 90 100 110 120 130 140 150

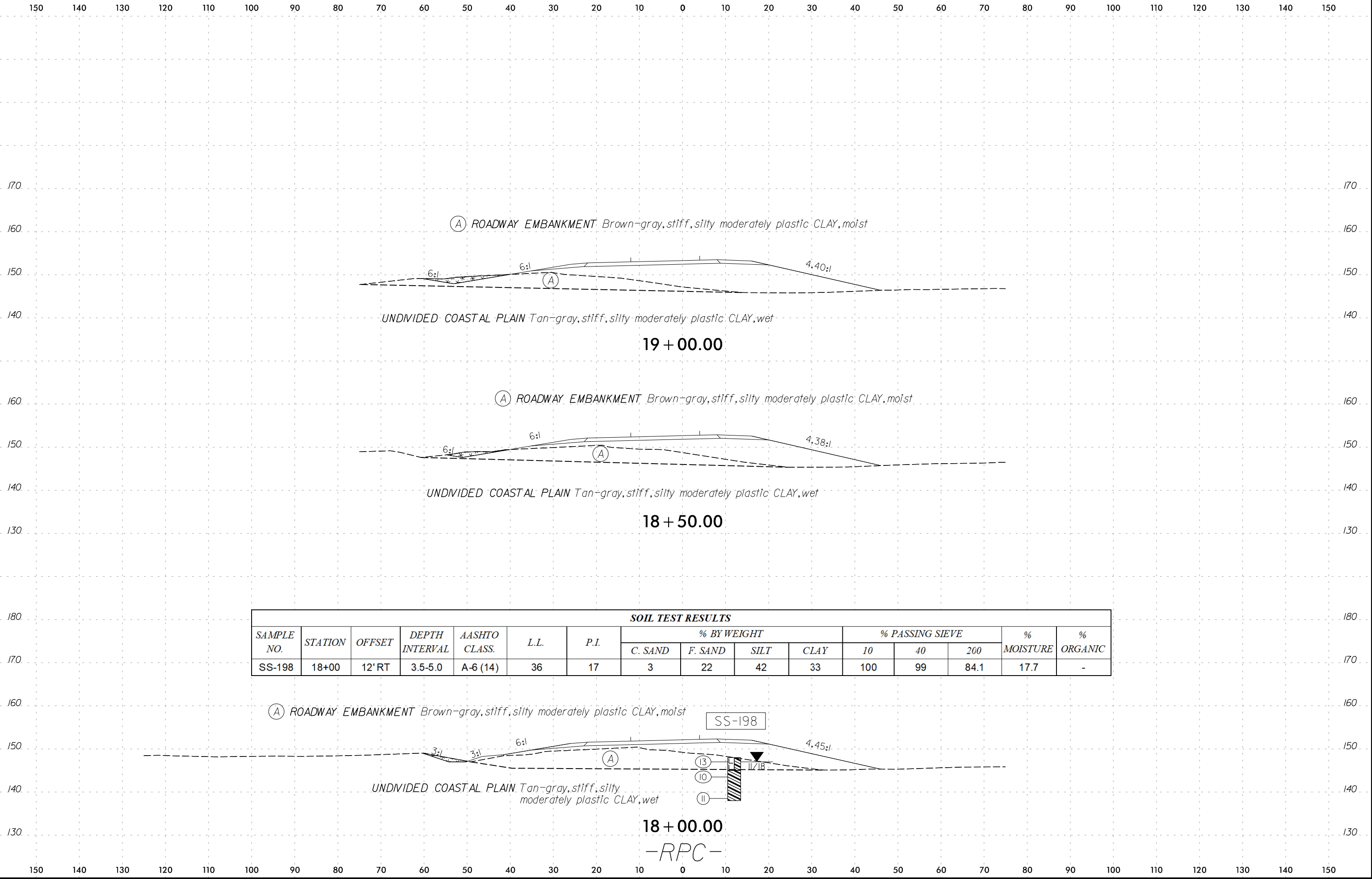

SOIL TEST RESULTS

SAMPLE NO.	STATION	OFFSET	DEPTH INTERVAL	AASHTO CLASS.	L.L.	P.I.	% BY WEIGHT				% PASSING SIEVE			% MOISTURE	% ORGANIC
							C. SAND	F. SAND	SILT	CLAY	10	40	200		
SS-198	18+00	12' RT	3.5-5.0	A-6 (14)	36	17	3	22	42	33	100	99	84.1	17.7	-

150 140 130 120 110 100 90 80 70 60 50 40 30 20 10 0 10 20 30 40 50 60 70 80 90 100 110 120 130 140 150

180 170 160 150 140 130 170 160 150 140 130

END UNCLASSIFIED EXCAVATION - ACCEPTABLE -RPC- STA. 20+75

(A) ROADWAY EMBANKMENT *Brown-gray, stiff silty moderately plastic CLAY, moist*

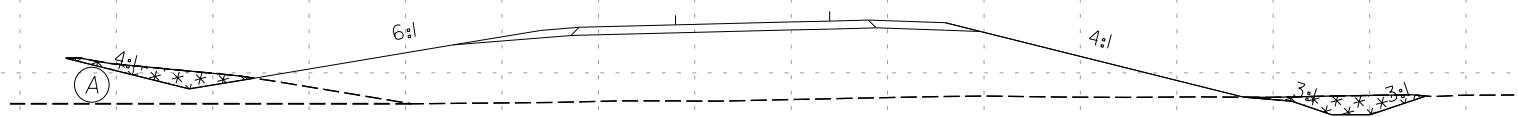

UNDIVIDED COASTAL PLAIN *Brown to tan, medium stiff to stiff, silty CLAY, moist*

Gray-tan to gray, stiff, clayey fine sandy SILT, wet

20 + 50.00

170 160 150 140 130 170 160 150 140 130

(A) ROADWAY EMBANKMENT *Brown-gray, stiff silty moderately plastic CLAY, moist*

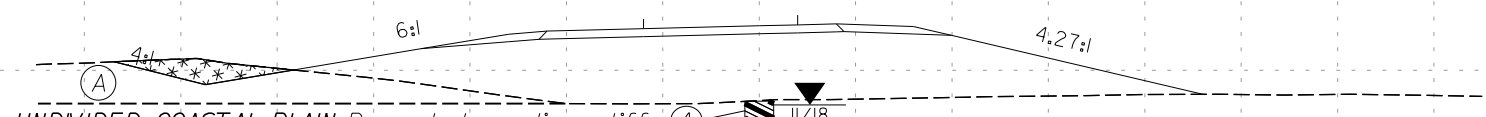

UNDIVIDED COASTAL PLAIN *Brown to tan, medium stiff to stiff, silty CLAY, moist*

Gray-tan to gray, stiff, clayey fine sandy SILT, wet

20 + 00.00

170 160 150 140 130 170 160 150 140 130

(A) ROADWAY EMBANKMENT *Brown-gray, stiff silty moderately plastic CLAY, moist*

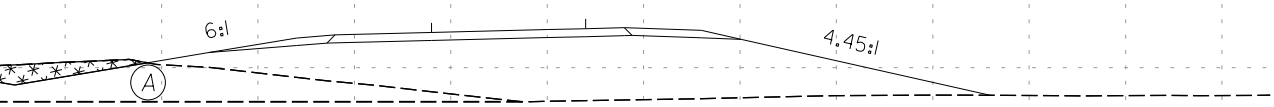

UNDIVIDED COASTAL PLAIN *Brown to tan, medium stiff to stiff, silty CLAY, moist*

Gray-tan to gray, stiff, clayey fine sandy SILT, wet

19 + 50.00

-RPC-

150 140 130 120 110 100 90 80 70 60 50 40 30 20 10 0 10 20 30 40 50 60 70 80 90 100 110 120 130 140 150

150 140 130 120 110 100 90 80 70 60 50 40 30 20 10 0 10 20 30 40 50 60 70 80 90 100 110 120 130 140 150

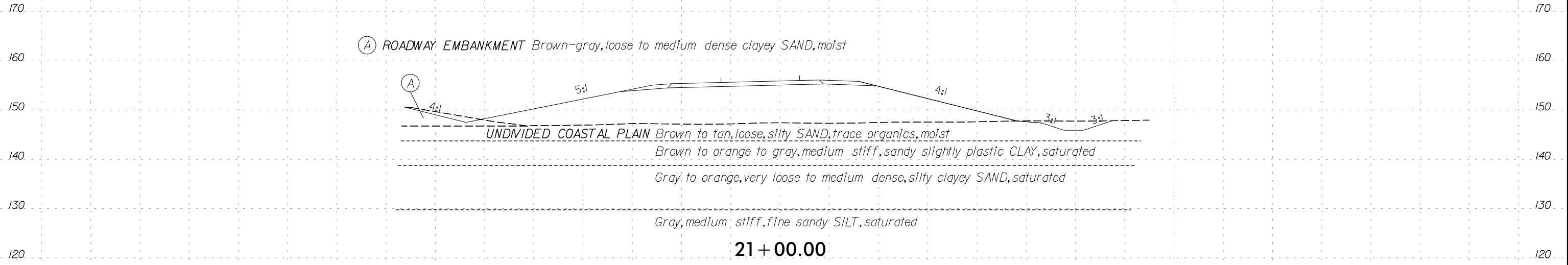

150 140 130 120 110 100 90 80 70 60 50 40 30 20 10 0 10 20 30 40 50 60 70 80 90 100 110 120 130 140 150

SOIL TEST RESULTS															
SAMPLE NO.	STATION	OFFSET	DEPTH INTERVAL	AASHTO CLASS.	L.L.	P.I.	% BY WEIGHT				% PASSING SIEVE			% MOISTURE	% ORGANIC
							C. SAND	F. SAND	SILT	CLAY	10	40	200		
SS-13	16+00	25' RT	0.0-1.5	A-6 (5)	37	20	37	22	16	25	99	71	44.6	14.5	-

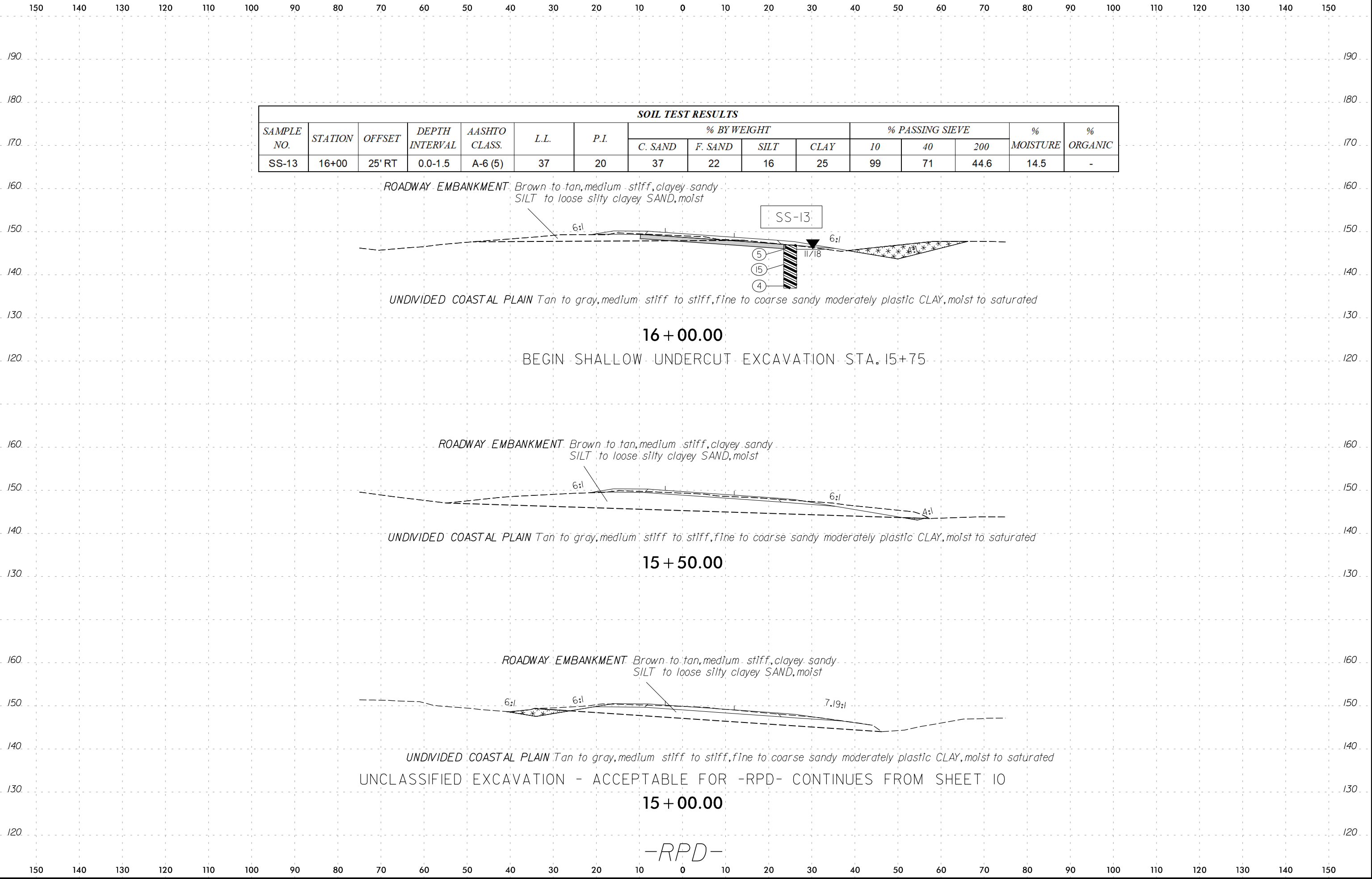

ROADWAY EMBANKMENT *Brown to tan, medium stiff, clayey sandy SILT to loose silty clayey SAND, moist*

SS-13

UNDIVIDED COASTAL PLAIN *Tan to gray, medium stiff to stiff, fine to coarse sandy moderately plastic CLAY, moist to saturated*

16 + 00.00

BEGIN SHALLOW UNDERCUT EXCAVATION STA. 15+75

ROADWAY EMBANKMENT *Brown to tan, medium stiff, clayey sandy SILT to loose silty clayey SAND, moist*

UNDIVIDED COASTAL PLAIN *Tan to gray, medium stiff to stiff, fine to coarse sandy moderately plastic CLAY, moist to saturated*

15 + 50.00

ROADWAY EMBANKMENT *Brown to tan, medium stiff, clayey sandy SILT to loose silty clayey SAND, moist*

UNDIVIDED COASTAL PLAIN *Tan to gray, medium stiff to stiff, fine to coarse sandy moderately plastic CLAY, moist to saturated*

UNCLASSIFIED EXCAVATION - ACCEPTABLE FOR -RPD- CONTINUES FROM SHEET 10

15 + 00.00

-RPD-

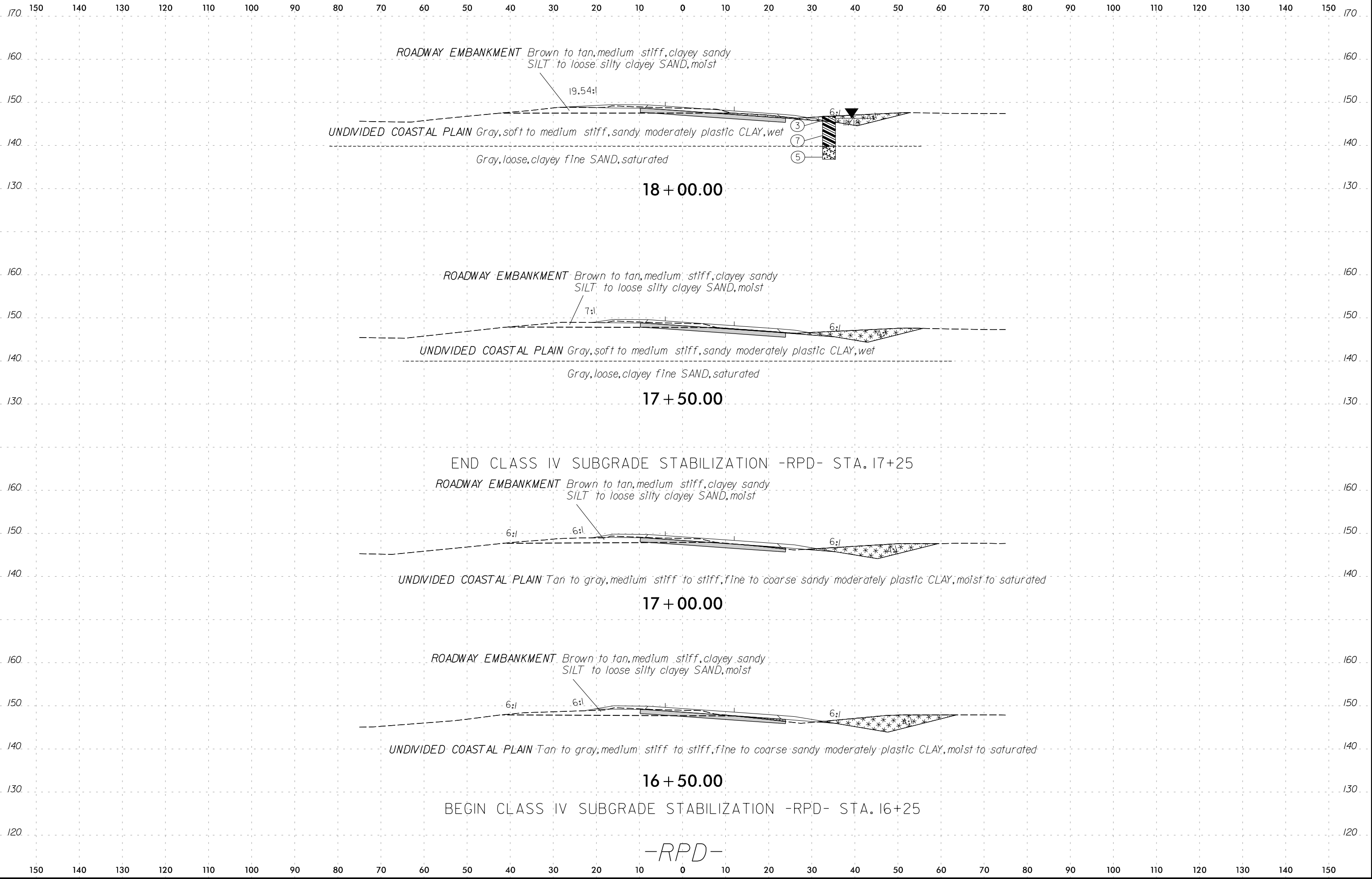

150 140 130 120 110 100 90 80 70 60 50 40 30 20 10 0 10 20 30 40 50 60 70 80 90 100 110 120 130 140 150

190 190

180 180

SOIL TEST RESULTS															
SAMPLE NO.	STATION	OFFSET	DEPTH INTERVAL	AASHTO CLASS.	L.L.	P.I.	% BY WEIGHT				% PASSING SIEVE			% MOISTURE	% ORGANIC
							C. SAND	F. SAND	SILT	CLAY	10	40	200		
SS-26	19+40	30' LT	3.5-5.0	A-6 (3)	27	13	30	23	21	26	100	87	50.8	19.6	-

170 170

160 160

150 150

140 140

160 160

150 150

140 140

130 130

160 160

150 150

140 140

130 130

150 140 130 120 110 100 90 80 70 60 50 40 30 20 10 0 10 20 30 40 50 60 70 80 90 100 110 120 130 140 150

9/29/2021 R:\Geotech\InvestigationDesign\CADD_GEO\TECH\XSC\Recommendations_graphics\I5972_GEO_XSR_RPD.dgn

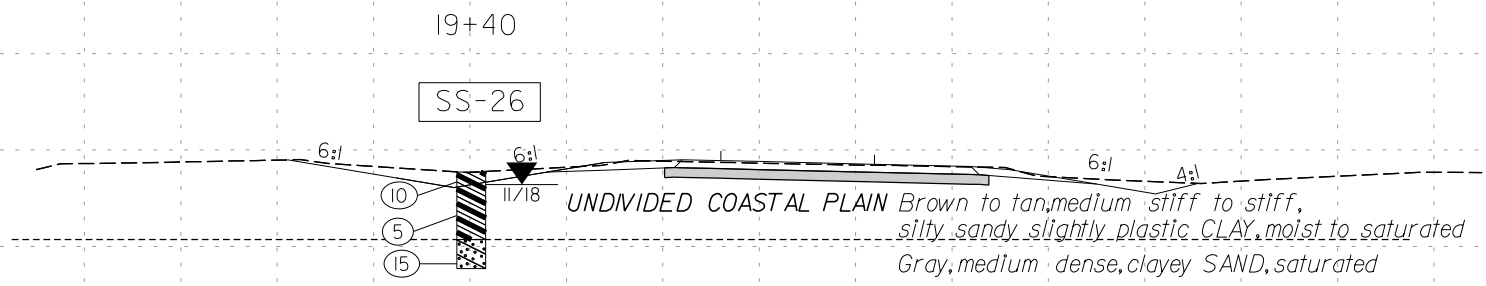

19 + 50.00

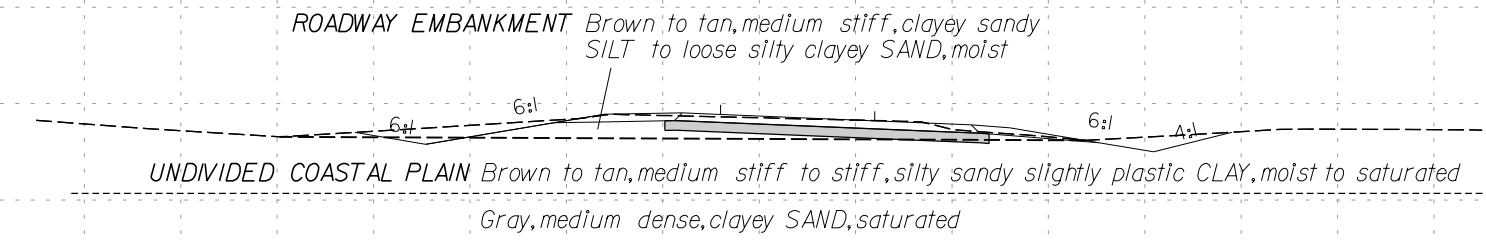

19 + 00.00

END UNCLASSIFIED EXCAVATION - ACCEPTABLE -RPD- STA. 18+75

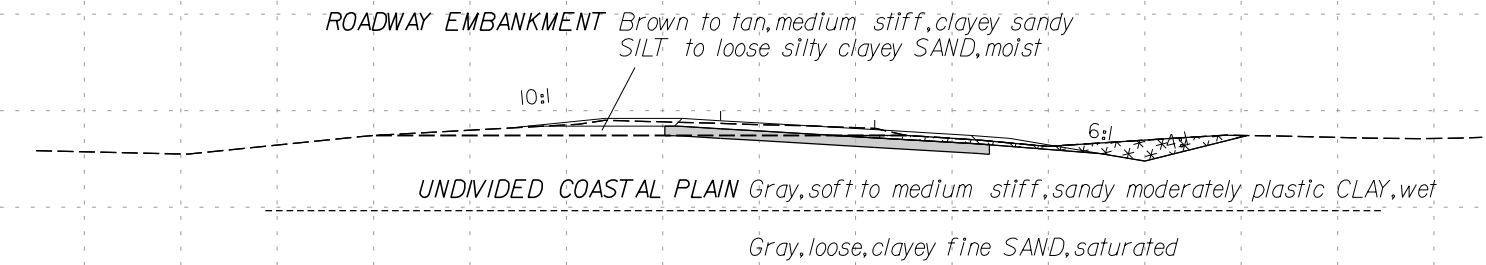

18 + 50.00

-RPD-

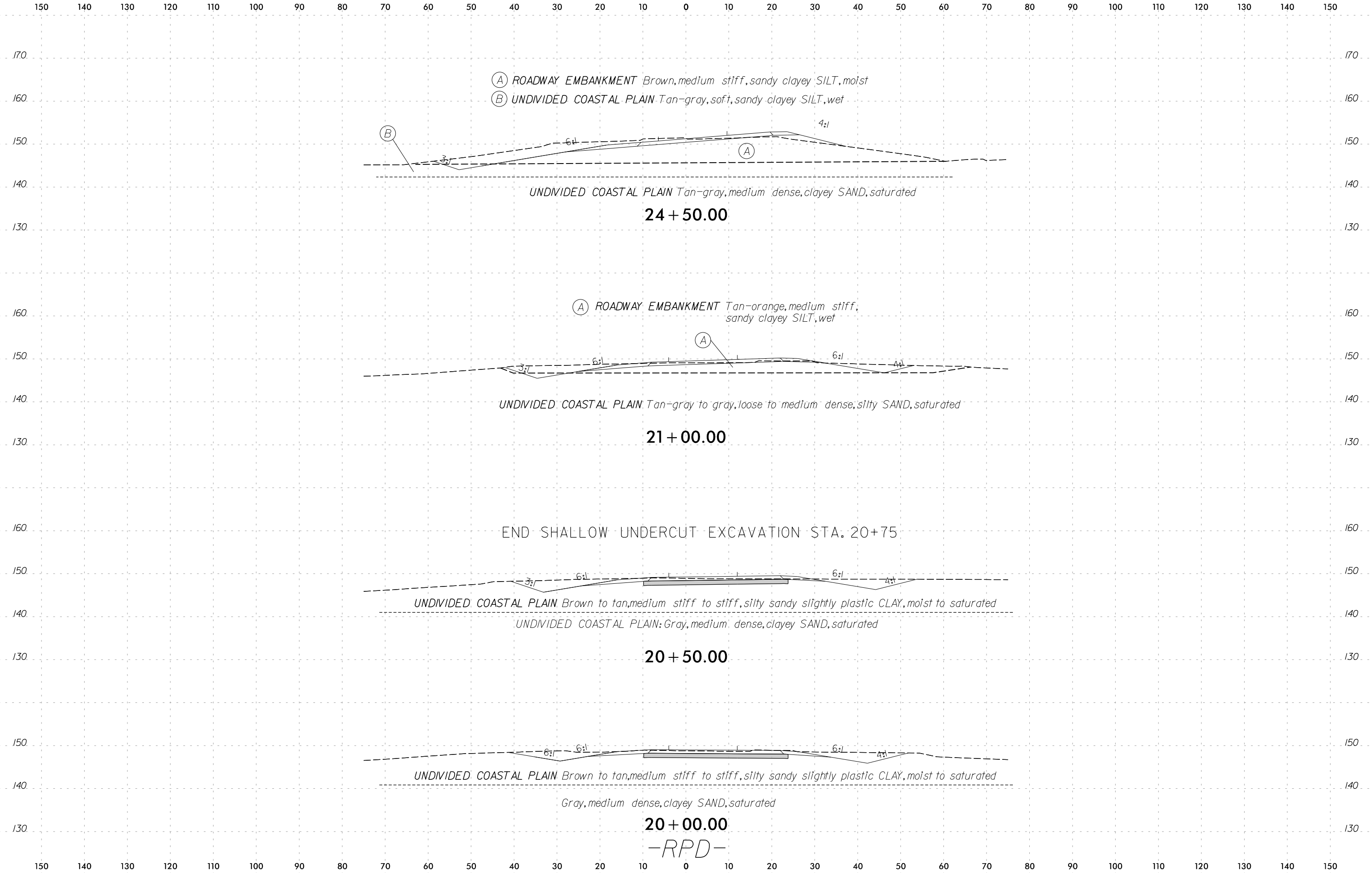

150 140 130 120 110 100 90 80 70 60 50 40 30 20 10 0 10 20 30 40 50 60 70 80 90 100 110 120 130 140 150

190 180 170 160 150 140 130 120 110 100 90 80 70 60 50 40 30 20 10 0 10 20 30 40 50 60 70 80 90 100 110 120 130 140 150

SOIL TEST RESULTS															
SAMPLE NO.	STATION	OFFSET	DEPTH INTERVAL	AASHTO CLASS.	L.L.	P.I.	% BY WEIGHT				% PASSING SIEVE			% MOISTURE	% ORGANIC
							C. SAND	F. SAND	SILT	CLAY	10	40	200		
SS-35	26+00	31' RT	3.5-5.0	A-6 (4)	36	18	34	25	17	24	100	80	45.7	18.9	-

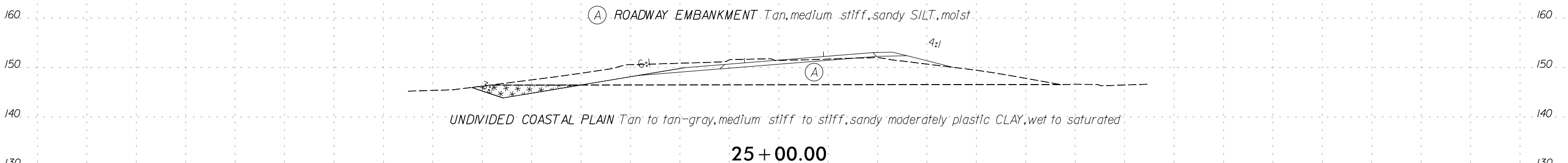
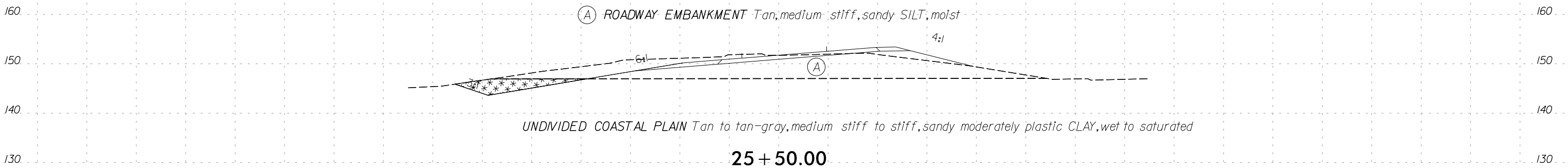
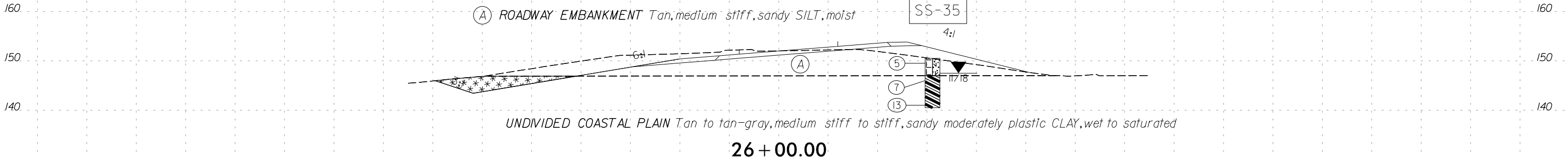

BEGIN UNCLASSIFIED EXCAVATION - ACCEPTABLE -RPD- STA. 24+75

-RPD-

150 140 130 120 110 100 90 80 70 60 50 40 30 20 10 0 10 20 30 40 50 60 70 80 90 100 110 120 130 140 150

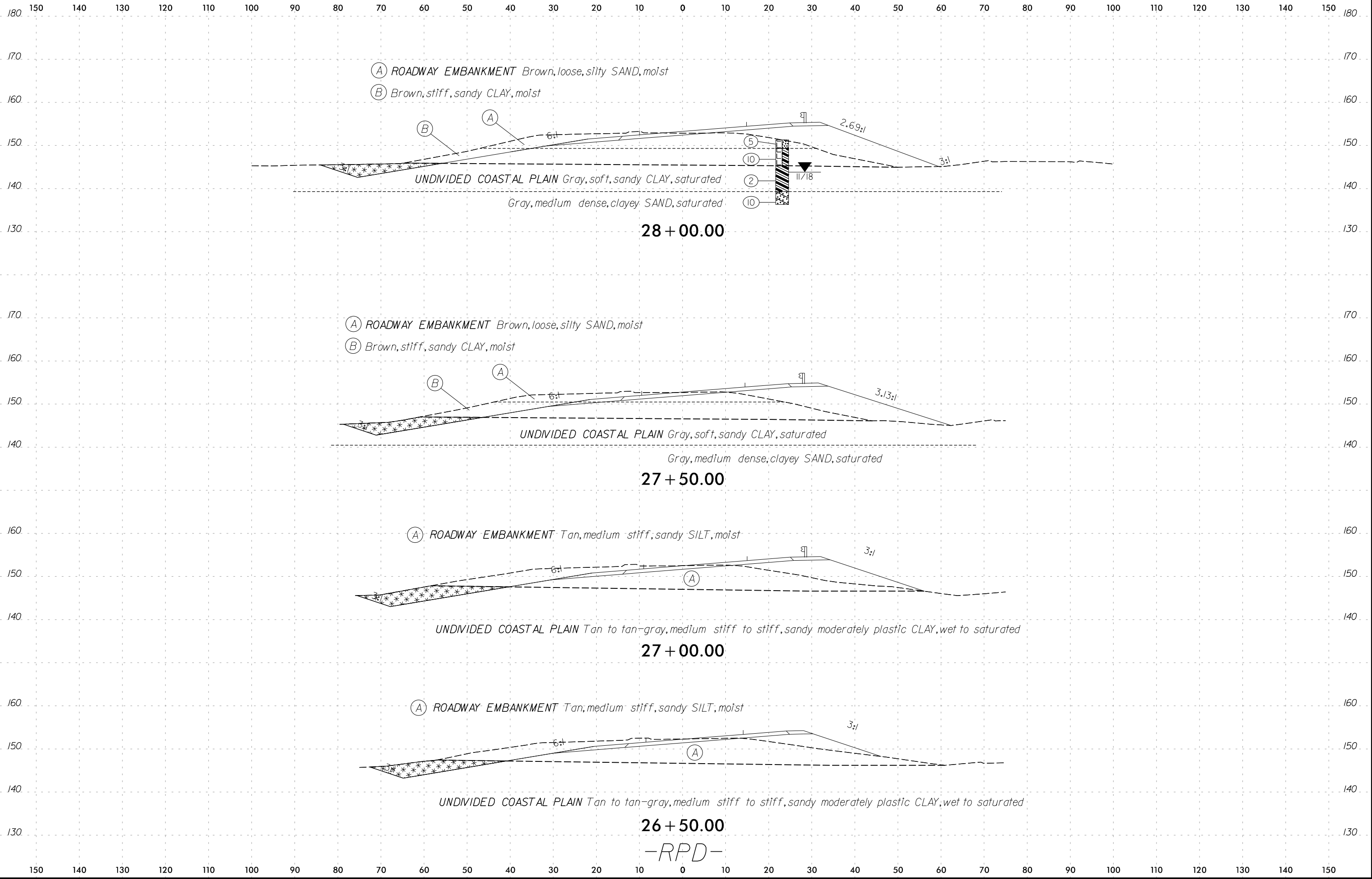

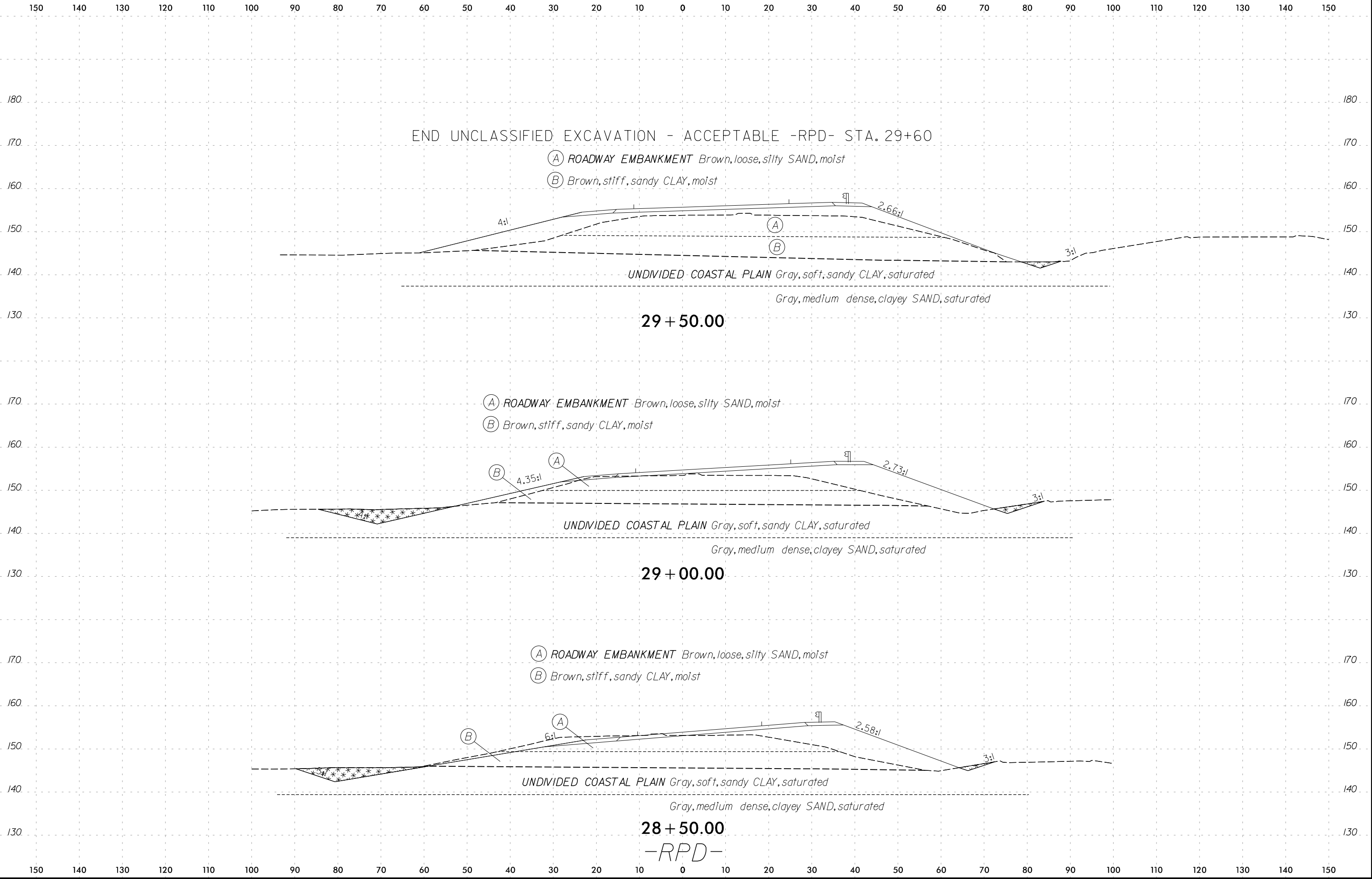

END UNCLASSIFIED EXCAVATION - ACCEPTABLE -RPD- STA. 29+60

- (A) ROADWAY EMBANKMENT *Brown, loose, silty SAND, moist*
- (B) *Brown, stiff, sandy CLAY, moist*

UNDIVIDED COASTAL PLAIN *Gray, soft, sandy CLAY, saturated*

Gray, medium dense, clayey SAND, saturated

29 + 50.00

- (A) ROADWAY EMBANKMENT *Brown, loose, silty SAND, moist*
- (B) *Brown, stiff, sandy CLAY, moist*

UNDIVIDED COASTAL PLAIN *Gray, soft, sandy CLAY, saturated*

Gray, medium dense, clayey SAND, saturated

29 + 00.00

- (A) ROADWAY EMBANKMENT *Brown, loose, silty SAND, moist*
- (B) *Brown, stiff, sandy CLAY, moist*

UNDIVIDED COASTAL PLAIN *Gray, soft, sandy CLAY, saturated*

Gray, medium dense, clayey SAND, saturated

28 + 50.00

-RPD-

