

DocuSigned by:
Bryan Bailey
 ENGINEER
 UTILITY CONSTRUCTION PLANS
**DOCUMENT NOT CONSIDERED FINAL
 UNLESS ALL SIGNATURES COMPLETED**

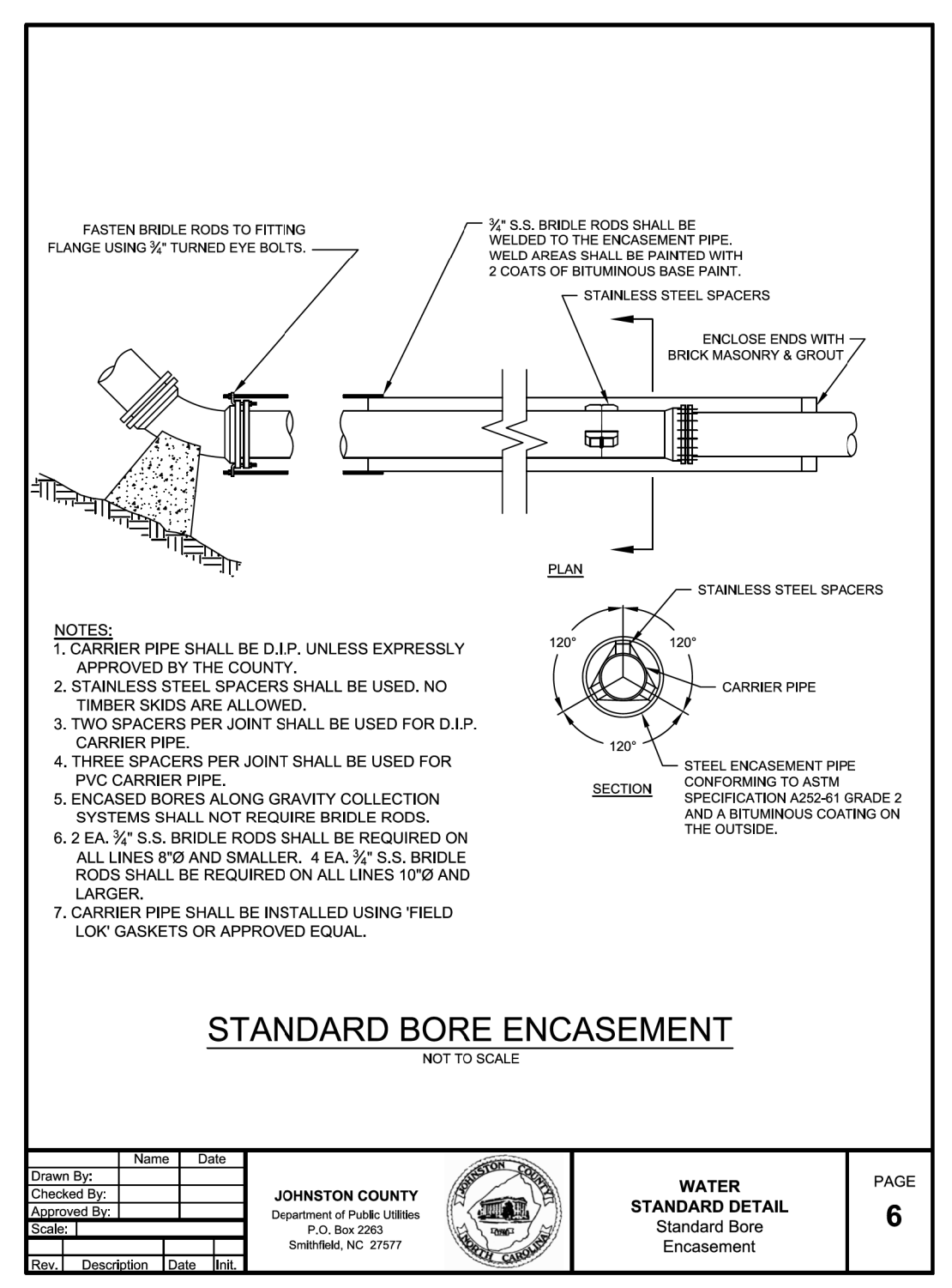
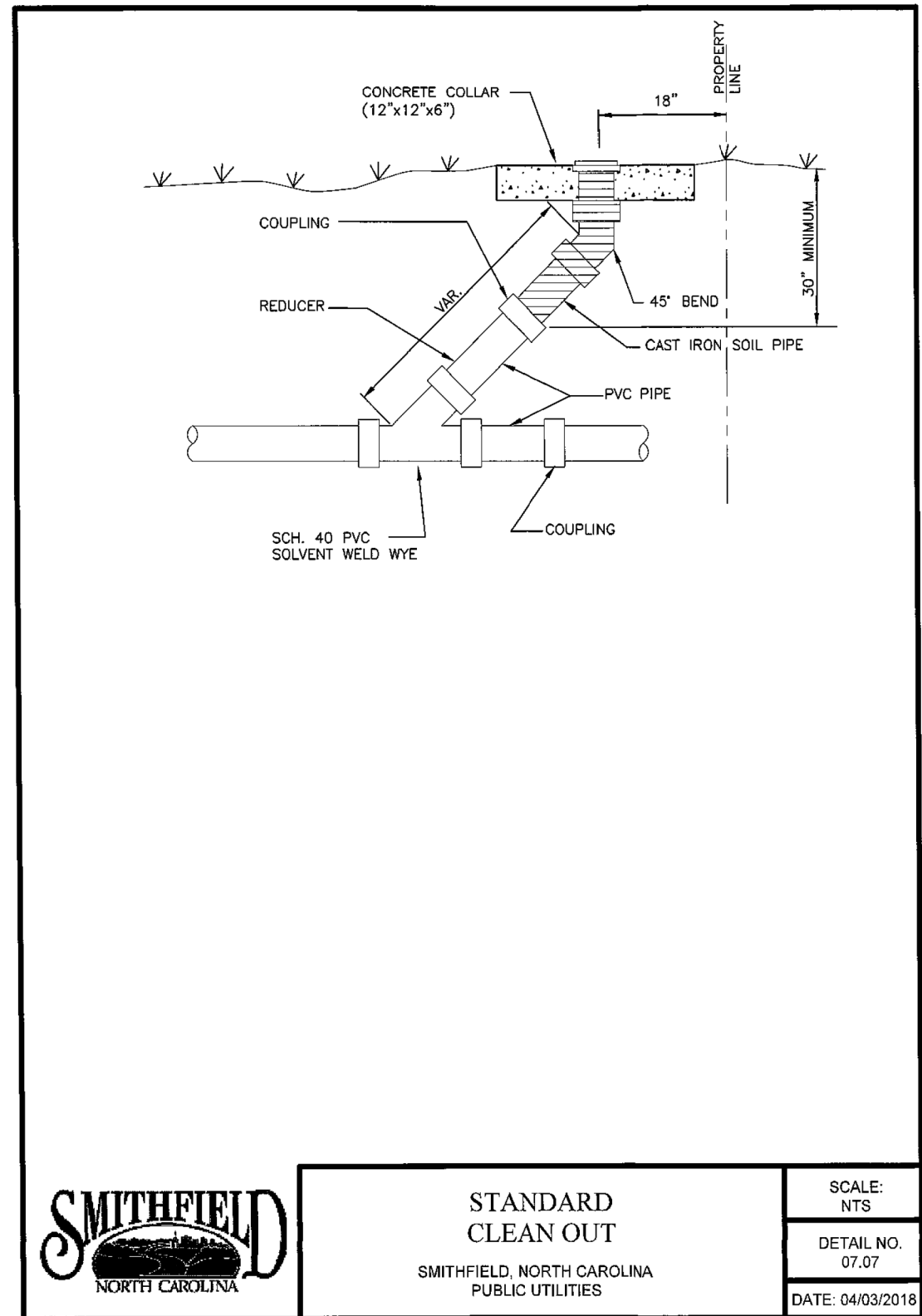
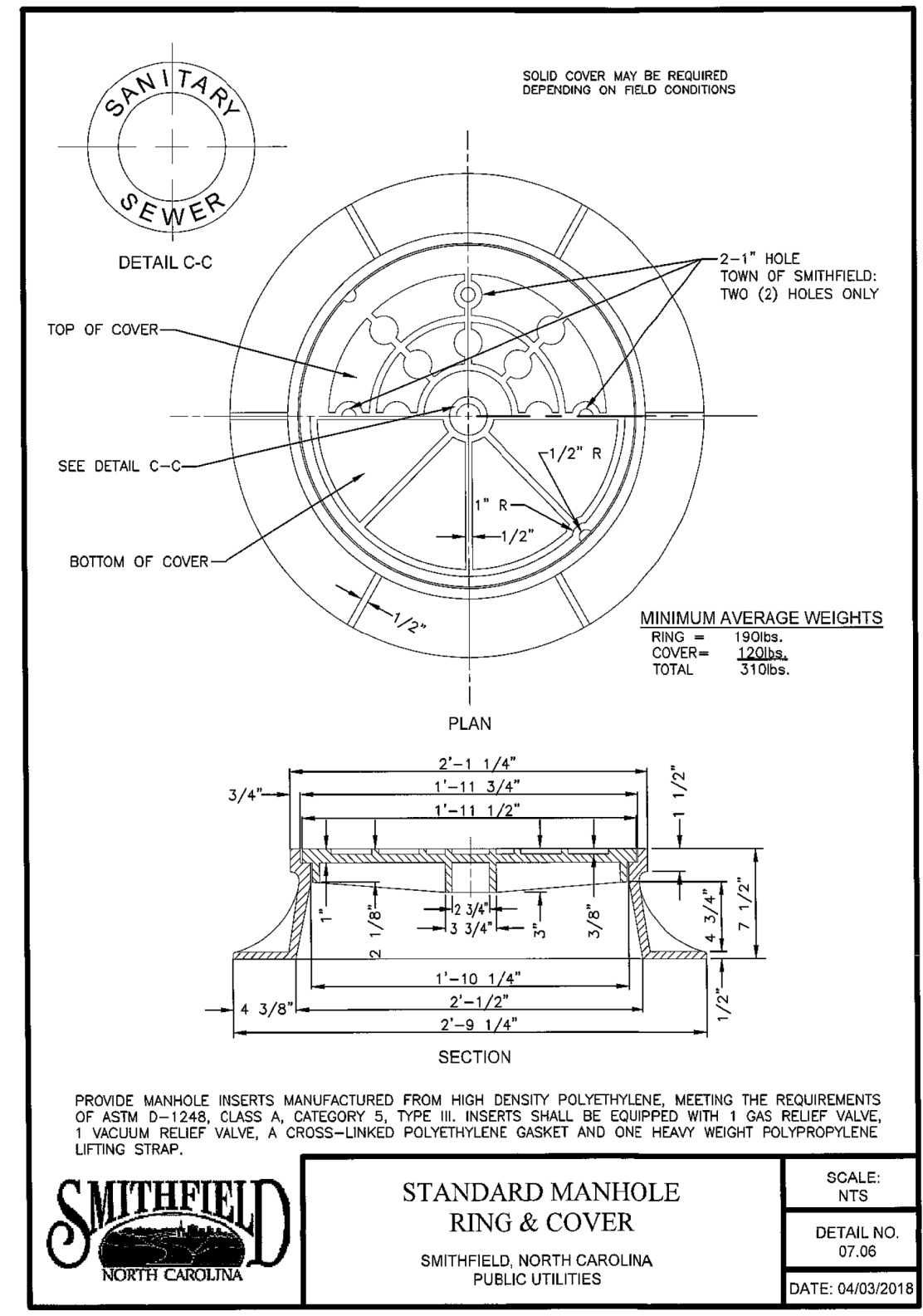
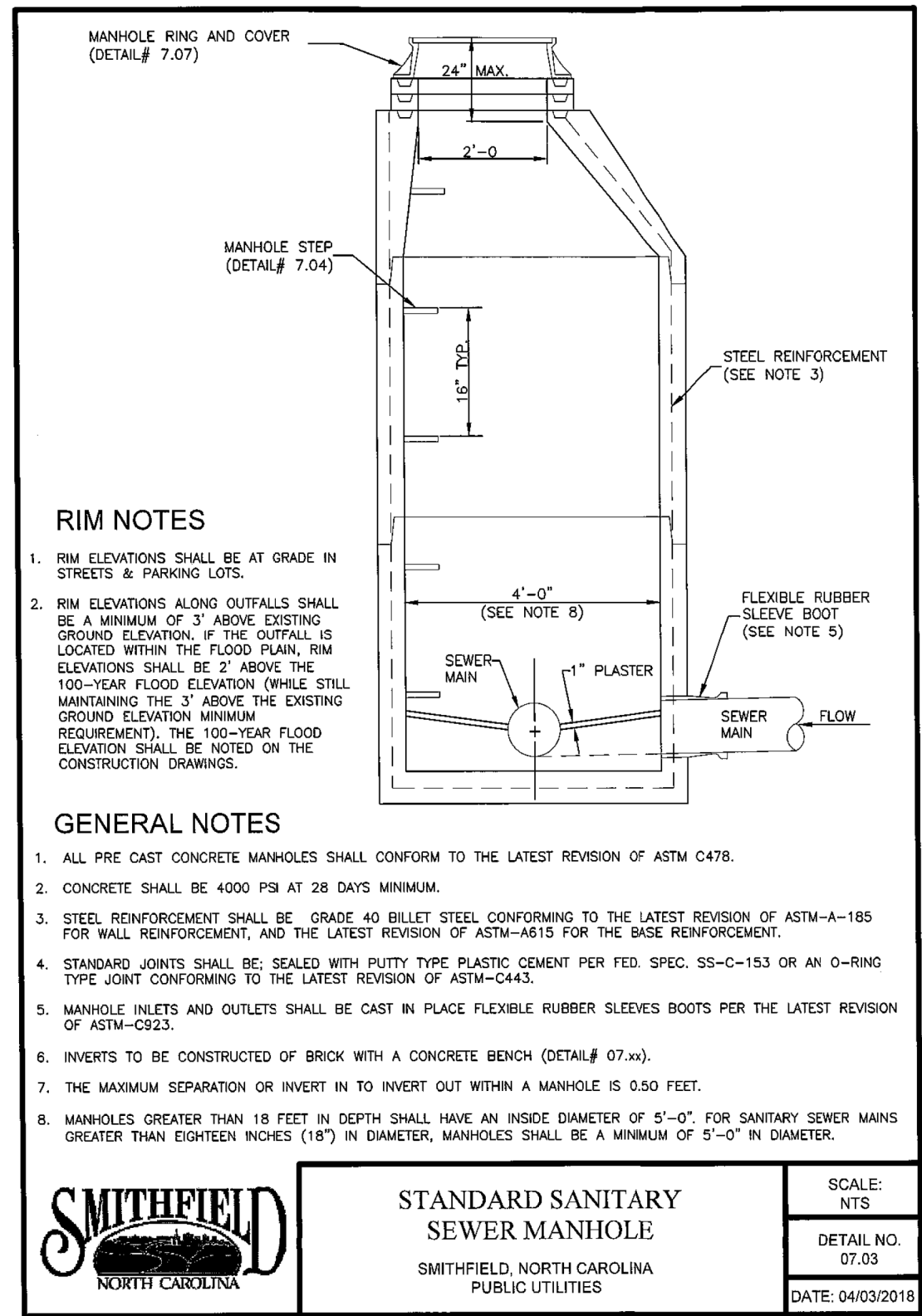

8/17/199
 R:\Projects\Engineering\UC\Proj\15972-ut-dt1_UC3b_psh.dgn
 8/11/2023
 bbailey